

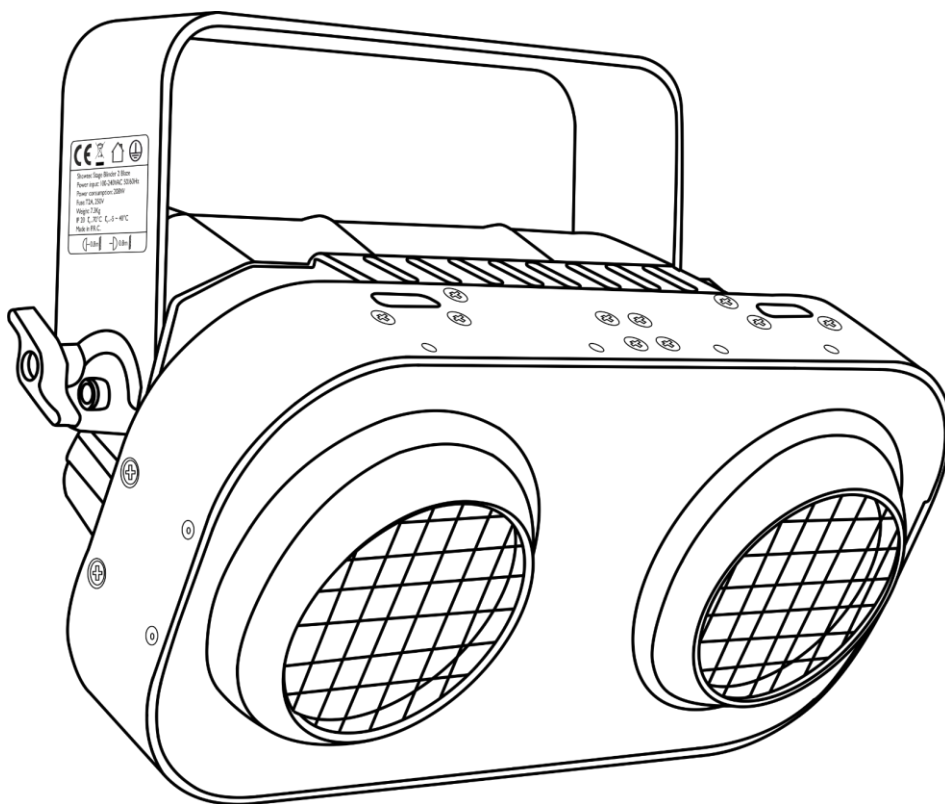

# MANUAL



ENGLISH

## Stage Blinder 2 Blaze

## V1

Ordercode: 30782

**Table of contents**

**Warning** ..... 2

    Safety Instructions ..... 2

    Operating Determinations ..... 4

    Rigging ..... 4

    Connection with the mains ..... 5

    Return Procedure ..... 6

    Claims ..... 6

**Description of the device** ..... 7

    Overview ..... 7

    Backside ..... 8

**Installation** ..... 8

**Set Up and Operation** ..... 8

    Control Modes ..... 9

        One Stage Blinder (Auto, Built-in programs, Manual and Halogen) ..... 9

        Multiple Stage Blinders (Master/Slave control) ..... 9

        Multiple Stage Blinders (DMX Control) ..... 10

    Fixture Linking ..... 11

    Data Cabling ..... 11

    Control Panel ..... 12

    Control Mode ..... 12

    DMX Addressing ..... 12

    Menu Overview ..... 13

    Main Menu Options ..... 15

        1. DMX Address/DMX Configuration ..... 15

        2. Manual Color mode ..... 16

        3. Halogen ..... 16

        4. Auto ..... 17

        5. Program ..... 17

        5.1. Program 1 ..... 18

        5.2. Programs 2-8 ..... 18

        6. Master/Slave ..... 18

        7. Settings ..... 19

        7.1. Curves Select ..... 19

        7.2. Dimmer Speed ..... 20

        7.3. DMX Fail ..... 20

        7.4. DMX Sync ..... 20

        7.5. Lock ..... 21

        7.6. Key Backlight ..... 21

        7.7. Factory ..... 21

        8. Information ..... 21

    DMX Channels ..... 22

        1 Channel ..... 22

        4 Channels ..... 22

        8 Channels ..... 22

        9 Channels ..... 23

**Maintenance** ..... 24

**Troubleshooting** ..... 24

    No Light ..... 24

    No Response to DMX ..... 24

**Product Specifications** ..... 26

**Dimensions** ..... 27

**Notes** ..... 28

## Warning



**For your own safety, please read this user manual carefully  
before your initial start-up!**



### Unpacking Instructions

Immediately upon receiving this product, carefully unpack the carton and check the contents to ensure that all parts are present, and have been received in good condition. Notify the dealer immediately and retain packing material for inspection if any parts appear damaged from shipping or the carton itself shows signs of mishandling. Save the carton and all packing materials. In the event that a fixture must be returned to the factory, it is important that the fixture be returned in the original factory box and packing.

### Your shipment includes:

- Showtec Stage Blinder 2 Blaze
- Pro power True 1 to Schuko power cable (1,5 m)
- User manual

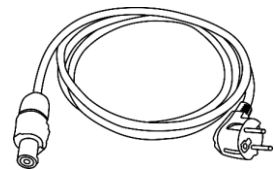
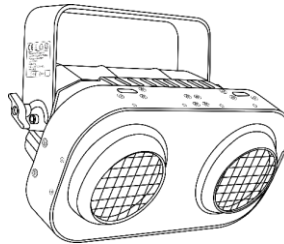

### LED Expected Lifespan

LEDs gradually decline in brightness over time. HEAT is the dominant factor that leads to the acceleration of this decline. Packaged in clusters, LEDs exhibit higher operating temperatures than in ideal or singular optimum conditions. For this reason when all color LEDs are used at their fullest intensity, life of the LEDs is significantly reduced. If improving your lifespan expectancy is of a higher priority, place care in providing for lower operational temperatures. This may include climatic-environmental and the reduction of overall projection intensity.



### CAUTION!

**Keep this device away from rain and moisture!  
Unplug mains lead before opening the housing!**



### Safety Instructions

Every person involved with the installation, operation and maintenance of this device has to:

- be qualified
- follow the instructions of this manual



**CAUTION! Be careful with your operations.  
With a dangerous voltage you can suffer  
a dangerous electric shock when touching the wires!**



Before your initial start-up, please make sure that there is no damage caused by transportation. Should there be any, consult your dealer and do not use the device.

To maintain perfect condition and to ensure a safe operation, it is absolutely necessary for the user to follow the safety instructions and warning notes written in this manual.

Please consider that damages caused by manual modifications to the device are not subject to warranty.

This device contains no user-serviceable parts. Refer servicing to qualified technicians only.

### IMPORTANT:

The manufacturer will not accept liability for any resulting damages caused by the non-observance of this manual or any unauthorized modification to the device.

- Never let the power cord come into contact with other cables! Handle the power cord and all connections with the mains with particular caution!
- Never modify, bend, mechanically strain, put pressure on, pull or heat up the power cord.
- Never strain the cable insert or the female part in the device. There must always be sufficient cable going to the device. Otherwise, the cable will be damaged, which can cause serious damage.
- Never remove warning or informative labels from the unit.
- Never use anything to cover the ground contact.
- Never lift the device holding it by the projector-head, as the mechanics may be damaged. Always hold the device by the transport handles.
- Never place any material over the LEDs or lens.
- Never look directly into the light source.
- Never leave any cables lying around.
- Never use the device during thunderstorms, unplug the device immediately.
- Never leave various parts of the packaging (plastic bags, polystyrene foam, nails, etc.) within children's reach, as they are potential sources of danger.
- Do not insert objects into air vents.
- Do not open the device and do not modify the device.
- Do not connect this device to a dimmer pack.
- Do not switch the device on and off in short intervals, as this will reduce the device's life.
- Do not touch the device's housing bare-handed during its operation (housing becomes hot). Allow the device to cool for at least 5 minutes before handling.
- Do not shake the device. Avoid brute force when installing or operating the device.
- Only operate the device after having checked if the housing is firmly closed and all screws are tightly fastened.
- Only operate the device after having familiarized with its functions.
- Avoid flames and do not put close to flammable liquids or gases.
- Always keep the case closed while operating.
- Always allow a free air space of at least 80 cm around the unit for ventilation.
- Always disconnect power from the mains, when device is not used or before cleaning! Only handle the power cord holding it by the plug. Never pull out the plug by tugging the power cord.
- Make sure that the device is not exposed to extreme heat, moisture or dust.
- Make sure that the available voltage is not higher than stated on the rear panel.
- Make sure that the power cord is never crimped or damaged. Check the device and the power cord from time to time.
- Make sure that the core diameter of extension cords and power cords is sufficient for the required power consumption of the device.
- If the lens or LEDs are obviously damaged, they have to be replaced to prevent its functions from being impaired, due to cracks or deep scratches.
- If the external cable is damaged, it has to be replaced by a qualified technician.
- If device was dropped or struck, disconnect mains power supply immediately. Have a qualified engineer inspect for safety before operating.
- If the device has been exposed to drastic temperature fluctuation (e.g. after transportation), do not switch it on immediately. The arising condensation water might damage your device. Leave the device switched off until it has reached room temperature.
- If your Showtec device fails to work properly, discontinue the use immediately. Pack the unit securely (preferably in the original packing material), and return it to your Showtec dealer for service.
- For adult use only. The device must be installed beyond the reach of children. Never leave the unit running unattended.
- Never attempt to bypass the thermostatic switch or fuses.
- For replacement use fuses of same type and rating only.
- The user is responsible for correct positioning and operating of the device. The manufacturer will not accept liability for damages caused by the misuse or incorrect installation of this device.
- This device falls under protection class I. Therefore it is essential to connect the yellow/green conductor to earth.
- Repairs, servicing and electric connection must be carried out by a qualified technician.
- WARRANTY: Till one year after date of purchase.



**CAUTION! Eyedamages!!!**  
**Avoid looking directly into the lightsource!!!**  
**(meant especially for epileptics)!!!**



### Operating Determinations

- This device is not designed for permanent operation. Consistent operation breaks will ensure that the device will serve you for a long time without defects.
- The minimum distance between light output and the illuminated surface must be bigger than 0,8 meter.
- In order to eliminate wear and improve the device's lifespan, during periods of non-use, completely disconnect from power source via breaker or by unplugging.
- The maximum ambient temperature  $t_a = 40^\circ\text{C}$  must never be exceeded.
- The relative humidity must not exceed 50 % with an ambient temperature of  $40^\circ\text{C}$ .
- If this device is operated in any other way than the one described in this manual, the product may suffer damages and the warranty becomes void.
- Any other operation may lead to dangers like short-circuit, burns, electric shock, crash, etc.

*You endanger your own safety and the safety of others!*

### Rigging

*Please follow the European and national guidelines concerning rigging, trussing and all other safety issues.*

*Do not attempt the installation yourself!*

*Always let the installation be carried out by an authorized dealer!*

### Procedure:

- If the Stage Blinder is lowered from the ceiling or high joists, professional trussing systems have to be used.
- Use a clamp to mount the Stage Blinder, with the mounting bracket, to the trussing system.
- The Stage Blinder must never be fixed swinging freely in the room.
- The installation must always be secured with a safety attachment, e.g. an appropriate safety net or safety cable.
- When rigging, derigging or servicing the Stage Blinder, always make sure, that the area below the installation place is blocked and staying in the area is forbidden.

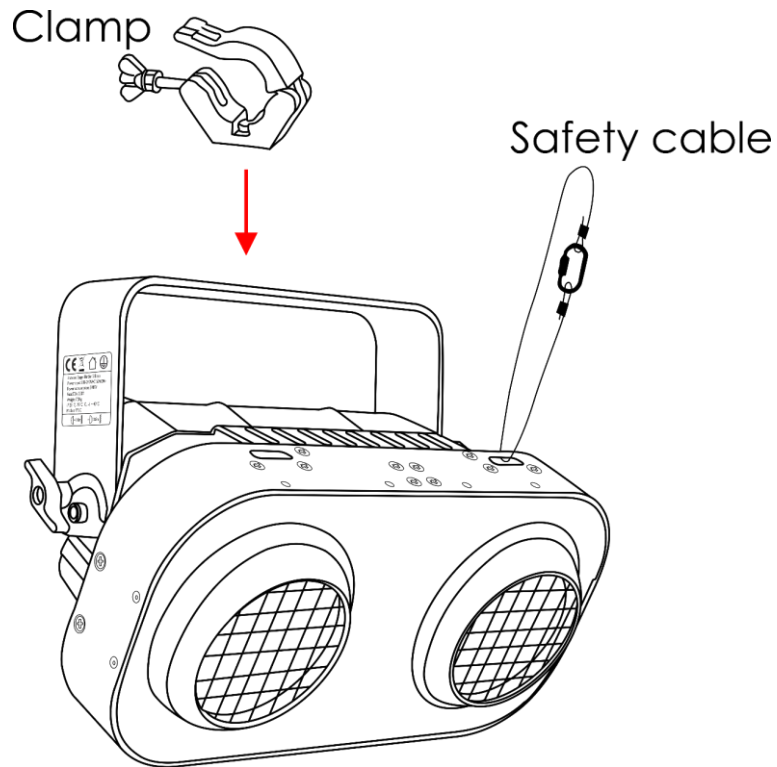

The Stage Blinder 2 Blaze can be placed on a flat surface or fitted to any kind of truss with a clamp.

*Improper installation can cause serious damage to people and property!*

**Connection with the mains**

Connect the device to the mains with the power-plug.

Always pay attention, that the right color cable is connected to the right place.

| International | EU Cable     | UK Cable | US Cable      | Pin               |
|---------------|--------------|----------|---------------|-------------------|
| L             | BROWN        | RED      | YELLOW/COPPER | PHASE             |
| N             | BLUE         | BLACK    | SILVER        | NEUTRAL           |
| ⊕             | YELLOW/GREEN | GREEN    | GREEN         | PROTECTIVE GROUND |

*Make sure that the device is always connected properly to the earth!*

*Improper installation can cause serious damage to people and property!*



### **Return Procedure**

Returned merchandise must be sent prepaid and in the original packing, call tags will not be issued. Package must be clearly labeled with a Return Authorization Number (RMA number). Products returned without an RMA number will be refused. Highlite will not accept the returned goods or any responsibility. Call Highlite 0031-455667723 or mail [offersales@highlite.com](mailto:offersales@highlite.com) and request an RMA prior to shipping the fixture. Be prepared to provide the model number, serial number and a brief description of the cause for the return. Be sure to properly pack fixture, any shipping damage resulting from inadequate packaging is the customer's responsibility. Highlite reserves the right to use its own discretion to repair or replace product(s). As a suggestion, proper UPS packing or double-boxing is always a safe method to use.

**Note: If you are given an RMA number, please include the following information on a piece of paper inside the box:**

- 01) Your name
- 02) Your address
- 03) Your phone number
- 04) A brief description of the symptoms

### **Claims**

The client has the obligation to check the delivered goods immediately upon delivery for any shortcomings and/or visible defects, or perform this check after our announcement that the goods are at their disposal. Damage incurred in shipping is the responsibility of the shipper; therefore the damage must be reported to the carrier upon receipt of merchandise.

It is the customer's responsibility to notify and submit claims with the shipper in the event that a fixture is damaged due to shipping. Transportation damage has to be reported to us within one day after receipt of the delivery.

Any return shipment has to be made post-paid at all times. Return shipments must be accompanied with a letter defining the reason for return shipment. Non-prepaid return shipments will be refused, unless otherwise agreed in writing.

Complaints against us must be made known in writing or by fax within 10 working days after receipt of the invoice. After this period complaints will not be handled anymore.

Complaints will only then be considered if the client has so far complied with all parts of the agreement, regardless of the agreement of which the obligation is resulting.

## Description of the device

### Features

The Showtec Stage Blinder 2 Blaze is a compact and powerful blinder with high output and great effects.

- Very punchy 2-head blinder
- RGB blaze effect
- Manual Pan adjustment of each head
- Input voltage: 100-240V AC, 50/60Hz
- Power consumption: 205W
- Refresh rate: 4000Hz
- DMX channels: 1, 4, 8, 9 channels
- Light source: 2 x 100W Dual-White COB, SMD RGB Blaze
- Color temperature: 2100-3200K
- Pod movement: +/- 20° stepless
- Beam angle: 45°
- Field angle: 84°
- Dimmer: 0-100%
- Strobe: 0-20Hz
- IP rating: IP65
- Housing: Black powder-coated metal
- DMX control: via standard DMX controller
- Onboard: OLED display for easy setup
- Control: Auto, Built-in programs, Manual, Halogen, Master/Slave, DMX-512
- Connections: Pro power True 1 power connector IN/OUT IP65, 3-pin DMX connector IN/OUT IP65
- Cooling: Cooling fans
- Dimensions: 400 x 220 x 262 mm (LxWxH)
- Weight: 7,3 kg

**Note:** Knowledge of DMX is required to fully utilize this unit.

### Overview

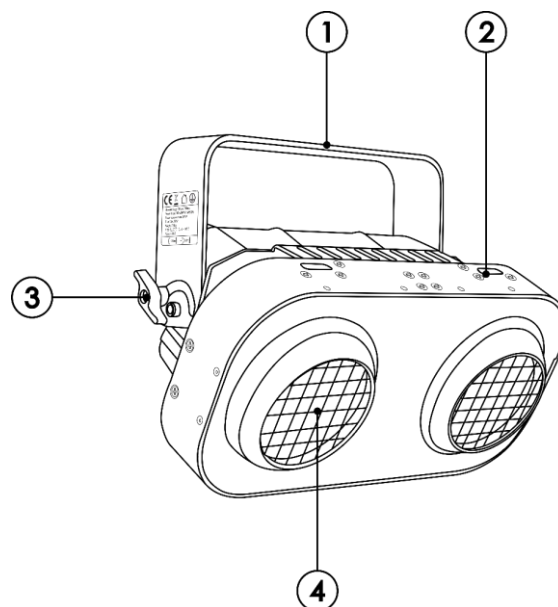

Fig. 01

- 01) Mounting bracket
- 02) Safety eye
- 03) Adjustment screw
- 04) 2 x 100W Dual-White COB, SMD RGB Blaze



## Backside

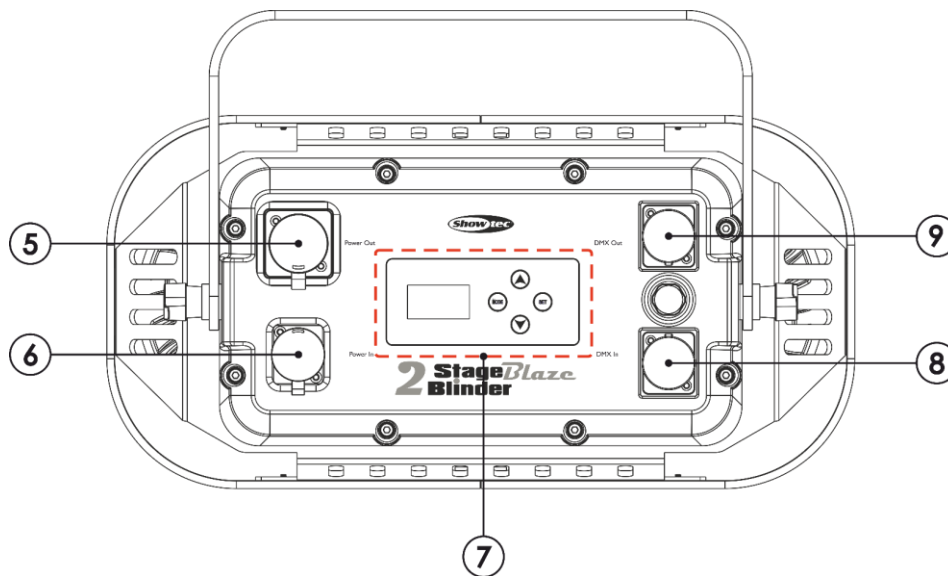

Fig. 02

- 05) Pro power True 1 power connector OUT IP65
- 06) Pro power True 1 power connector IN IP65
- 07) OLED display + control buttons
- 08) 3-pin DMX signal connector IN IP65
- 09) 3-pin DMX signal connector OUT IP65

## Installation

Remove all packing materials from the Stage Blinder 2 Blaze. Check that all foam and plastic padding is removed. Connect all cables.

**Do not supply power before the whole system is set up and connected properly.**

**Always disconnect from electric mains power supply before cleaning or servicing.**

**Damages caused by non-observance are not subject to warranty.**

## Set Up and Operation

Follow the directions below, as they pertain to your preferred operation mode.

Before plugging the unit in, always make sure that the power supply matches the product specification voltage. Do not attempt to operate a 120V specification product on 230V power, or vice versa.

## Control Modes

There are 6 modes:

- Auto
- Built-in programs
- Manual
- Halogen
- Master/Slave
- DMX-512 (1CH, 4CH, 8CH, 9CH)

### One Stage Blinder (Auto, Built-in programs, Manual and Halogen)

- 01) Fasten the effect light onto firm trussing. Leave at least 0,5 meter on all sides for air circulation.
- 02) Always use a safety cable (ordercode 70140 / 70141).
- 03) Plug the end of the electric mains power cord into a proper electric power supply socket.
- 04) When the Stage Blinder is not connected with a DMX cable, it functions as a stand-alone device. Please see pages 16-18 for more information about Auto, Built-in programs, Manual and Halogen.

### Multiple Stage Blinders (Master/Slave control)

- 01) Fasten the effect light onto firm trussing. Leave at least 0,5 meter on all sides for air circulation.
- 02) Always use a safety cable (ordercode 70140 / 70141).
- 03) Plug the end of the electric mains power cord into a proper electric power supply socket.
- 04) Use a 3-pin XLR cable to connect the Stage Blinder and other devices.

The pins:



1. Earth
2. Signal (-)
3. Signal (+)

- 05) Link the units as shown in fig. 03. Connect a DMX signal cable from the first unit's DMX "out" socket to the second unit's "in" socket. Repeat this process to link the second, third and fourth units. You can use the same functions on the master device as described on pages 16-18 (Auto, Built-in programs, Manual and Halogen). This means that you can set your desired operation mode on the master device and all slave devices will react the same as the master device.

### Multiple Stage Blinders (Master/Slave control)

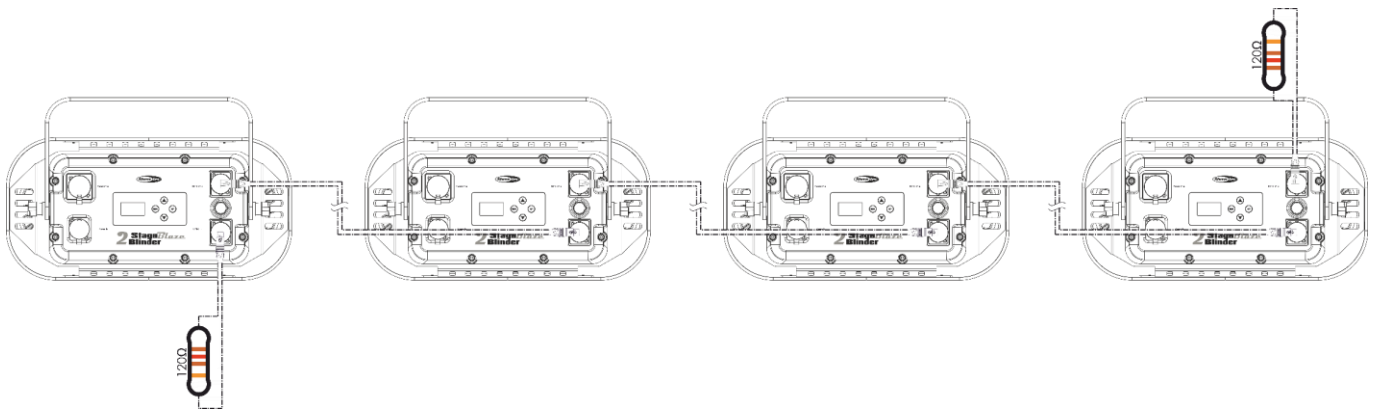
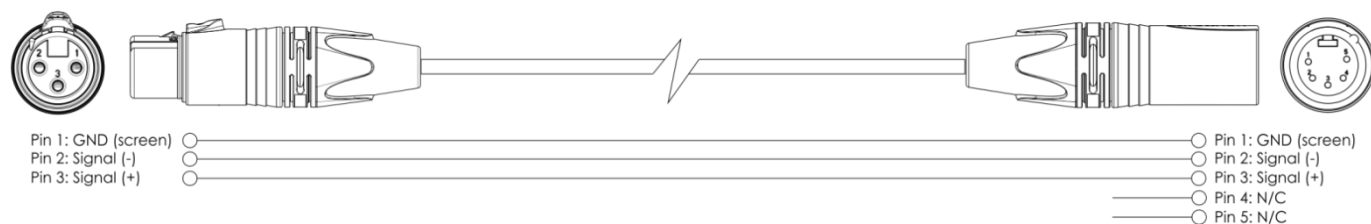
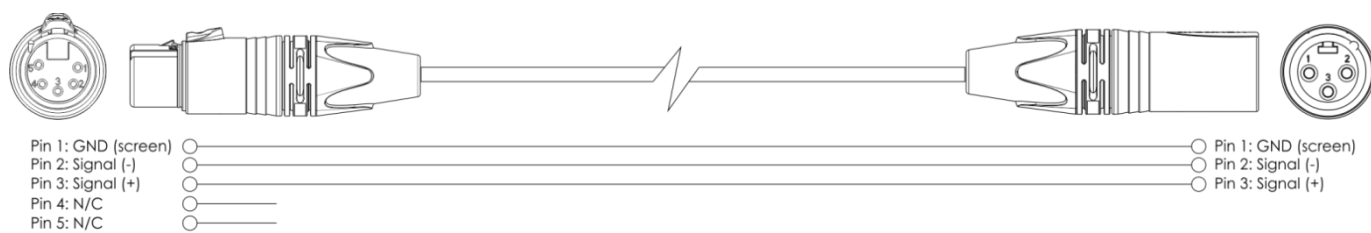

Fig. 03

## Multiple Stage Blinders (DMX Control)

- 01) Fasten the effect light onto firm trussing. Leave at least 0,5 meter on all sides for air circulation.
- 02) Always use a safety cable (ordercode 70140 / 70141).
- 03) Plug the end of the electric mains power cord into a proper electric power supply socket.
- 04) Use a 3-pin XLR cable to connect the Stage Blinder and other devices.



- 05) Link the units as shown in fig. 04. Connect a DMX signal cable from the first unit's DMX "out" socket to the second unit's "in" socket. Repeat this process to link the second, third and fourth units.
- 06) Supply electric power: Plug electric mains power cords into each unit's Pro power True 1 socket, then plug the other end of the mains power cord into proper electric power supply sockets, starting with the first unit. Do not supply power before the whole system is set up and connected properly.

## Multiple Stage Blinders DMX Set Up

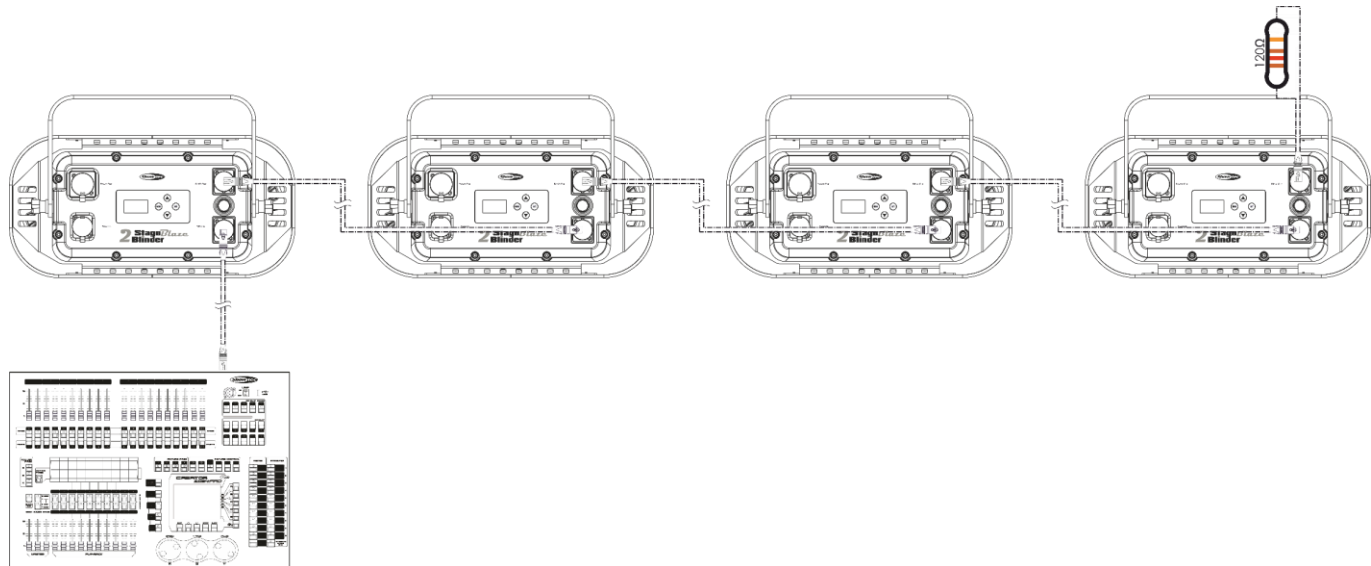

Fig. 04

**Note: Link all cables before connecting electric power**

### Fixture Linking

You will need a serial data link to run light shows of one or more fixtures using a DMX-512 controller or to run synchronized shows on two or more fixtures set to a master/slave operating mode. The combined number of channels required by all the fixtures on a serial data link determines the number of fixtures the data link can support.

#### Important:

Fixtures on a serial data link must be daisy chained in one single line. To comply with the EIA-485 standard no more than 30 devices should be connected on one data link. Connecting more than 30 fixtures on one serial data link without the use of a DMX optically isolated splitter may result in deterioration of the digital DMX signal.

Maximum recommended DMX data link distance: 100 meters  
Maximum recommended number of Stage Blinders on a DMX data link: 30 fixtures  
Maximum recommended number of Stage Blinders on a power link @110V: 8 fixtures  
Maximum recommended number of Stage Blinders on a power link @240V: 17 fixtures



### Data Cabling

To link fixtures together you must obtain data cables. You can purchase DAP Audio certified DMX cables directly from a dealer/distributor or construct your own cable. If you choose to create your own cable please use data-grade cables that can carry a high quality signal and are less prone to electromagnetic interference.

#### DAP Audio DMX Data Cables

- DAP Audio Basic microphone cable for allround use. bal. XLR/M 3-pin > XLR/F 3-pin. **Ordercode** FL01150 (1,5 m), FL013 (3 m), FL016 (6 m), FL0110 (10 m), FL0115 (15 m), FL0120 (20 m).
- DAP Audio X-type data cable XLR/M 3-pin > XLR/F 3-pin. **Ordercode** FLX0175 (0,75 m), FLX01150 (1,5 m), FLX013 (3 m), FLX016 (6 m), FLX0110 (10 m).
- DAP Audio cable for the demanding user with exceptional audio-qualities and connector made by Neutrik®. **Ordercode** FL71150 (1,5 m), FL713 (3 m), FL716 (6 m), FL7110 (10 m).
- DAP Audio cable for the demanding user with exceptional audio-qualities and connector made by Neutrik®. **Ordercode** FL7275 (0,75 m), FL72150 (1,5 m), FL723 (3 m), FL726 (6 m), FL7210 (10 m).
- DAP Audio 110 Ohm cable with digital signal transmission. **Ordercode** FL0975 (0,75 m), FL09150 (1,5 m), FL093 (3 m), FL096 (6 m), FL0910 (10 m), FL0915 (15 m), FL0920 (20 m).
- DAP Audio data cable FL08 DMX/AES-EBU, XLR/M 5-pin > XLR/F 5-pin. **Ordercode** FL08150 (1,5 m), FL083 (3 m), FL086 (6 m), FL0810 (10 m), FL0820 (20 m).
- DAP Audio DMX adapter: 5-pin > 3-pin. **Ordercode** FLA29.
- DAP Audio DMX adapter: 3-pin > 5-pin. **Ordercode** FLA30.
- DAP Audio DMX Terminator 3-pin. **Ordercode** FLA42.
- DAP Audio DMX Terminator 5-pin. **Ordercode** FLA43.

**Note:** connect the Stage Blinder 2 Blaze with the dedicated special XLR cables for outdoor use.

[FL73150](#) – Neutrik DMX Cable 3-pin XLR IP65 (1,5 m)

[FL733](#) – Neutrik DMX Cable 3-pin XLR IP65 (3 m)

[FL736](#) – Neutrik DMX Cable 3-pin XLR IP65 (6 m)

[FL7310](#) – Neutrik DMX Cable 3-pin XLR IP65 (10 m)

The Stage Blinder 2 Blaze can be operated with a controller in **control mode** or without the controller in **stand-alone** mode.

### Control Panel

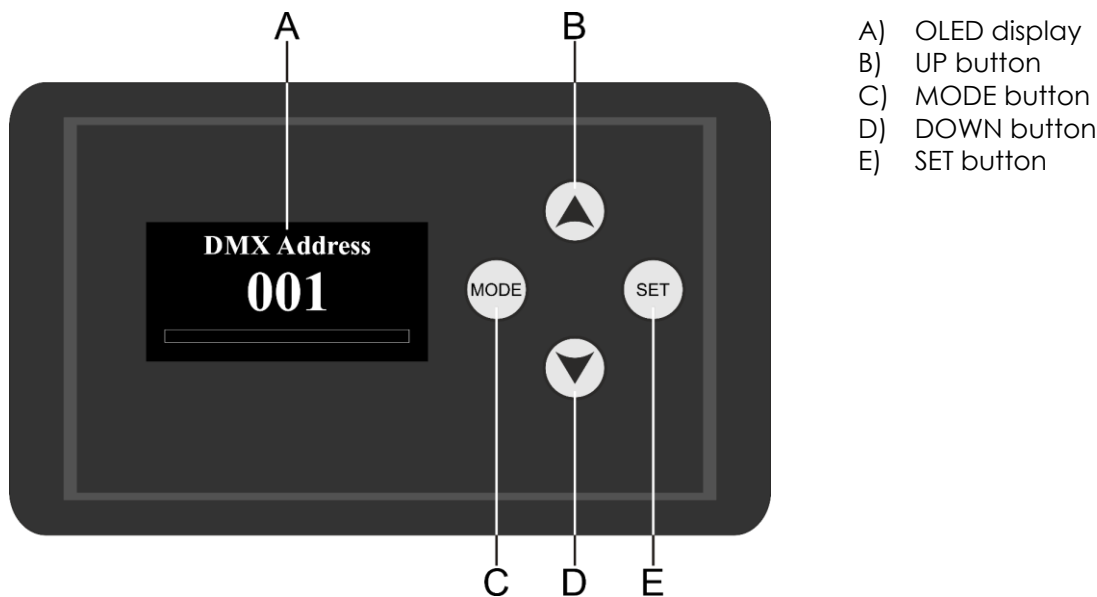

### Control Mode

The fixtures are individually addressed on a data-link and connected to the controller. The fixtures respond to the DMX signal from the controller. (When you select the DMX address and save it, the controller will display the saved DMX address the next time.)

### DMX Addressing

The control panel on the front side of the base allows you to assign the DMX fixture address, which is the first channel from which the Stage Blinder will respond to the controller.

Please note when you use the controller, the unit has **9** channels.

When using multiple Stage Blinders, make sure you set the DMX addresses right.

Therefore, the DMX address of the first Stage Blinder should be **1(001)**; the DMX address of the second Stage Blinder should be **1+9=10 (010)**; the DMX address of the third Stage Blinder should be **10+9=19 (019)**, etc. Please, be sure that you do not have any overlapping channels in order to control each Stage Blinder correctly. If two or more Stage Blinders are addressed similarly, they will work similarly.

### Controlling:

After having addressed all Stage Blinder fixtures, you may now start operating these via your lighting controller.

**Note:** After switching on, the Stage Blinder will automatically detect whether DMX 512 data is received or not. If there is no data received at the DMX-input, the problem may be:

- The XLR cable from the controller is not connected with the input of the Stage Blinder.
- The controller is switched off or defective, the cable or connector is defective, or the signal wires are swapped in the input connector.

**Note:** It's necessary to insert a XLR termination plug (with 120 Ohm) in the last fixture in order to ensure proper transmission on the DMX data link.

### Display Off after 30 seconds

When no button is pressed for 30 seconds, the display will turn off. To light up the display, you have to press the MODE, SET, UP or DOWN button. Once you have pressed the button, the display will light up.

Menu Overview

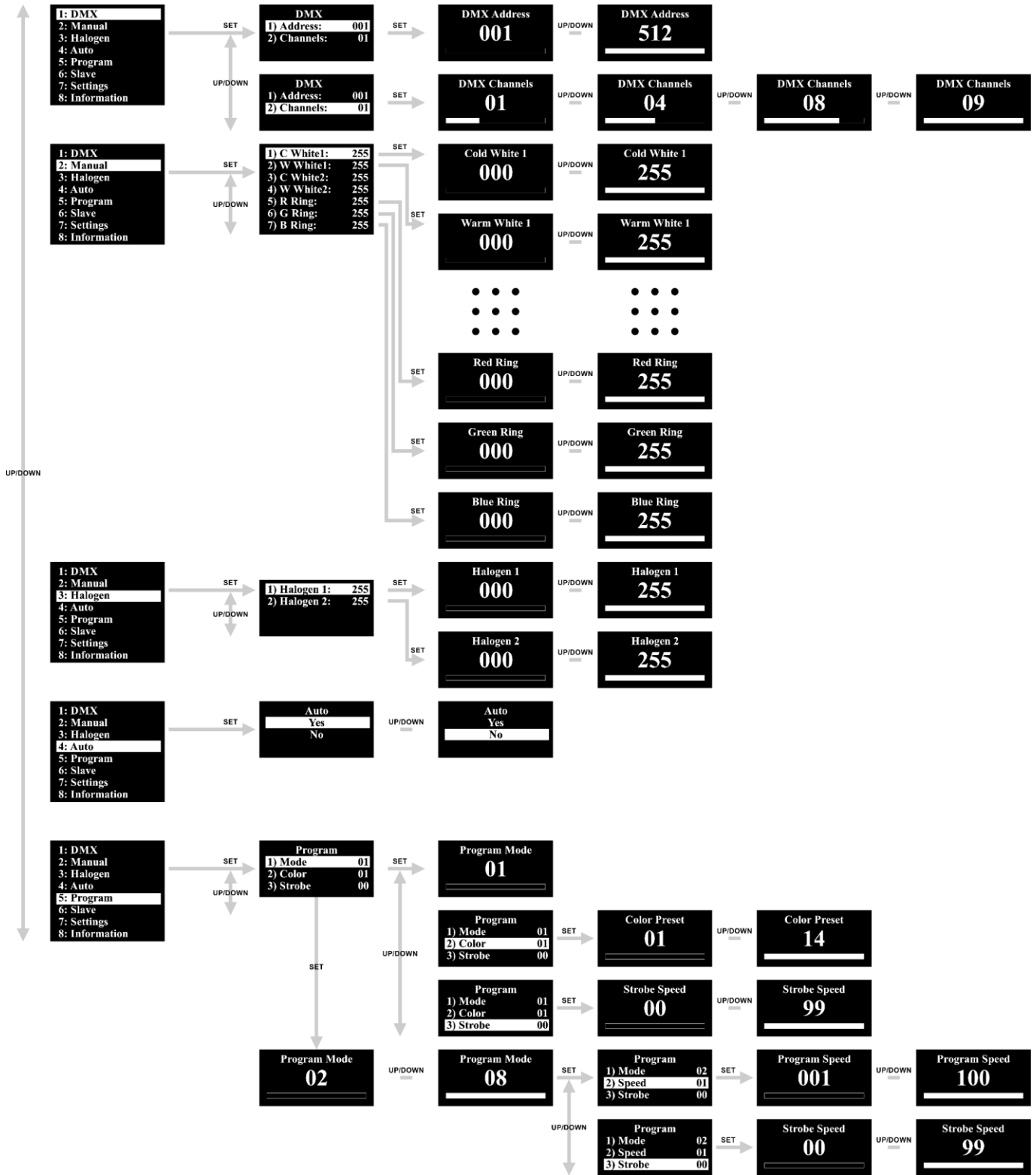

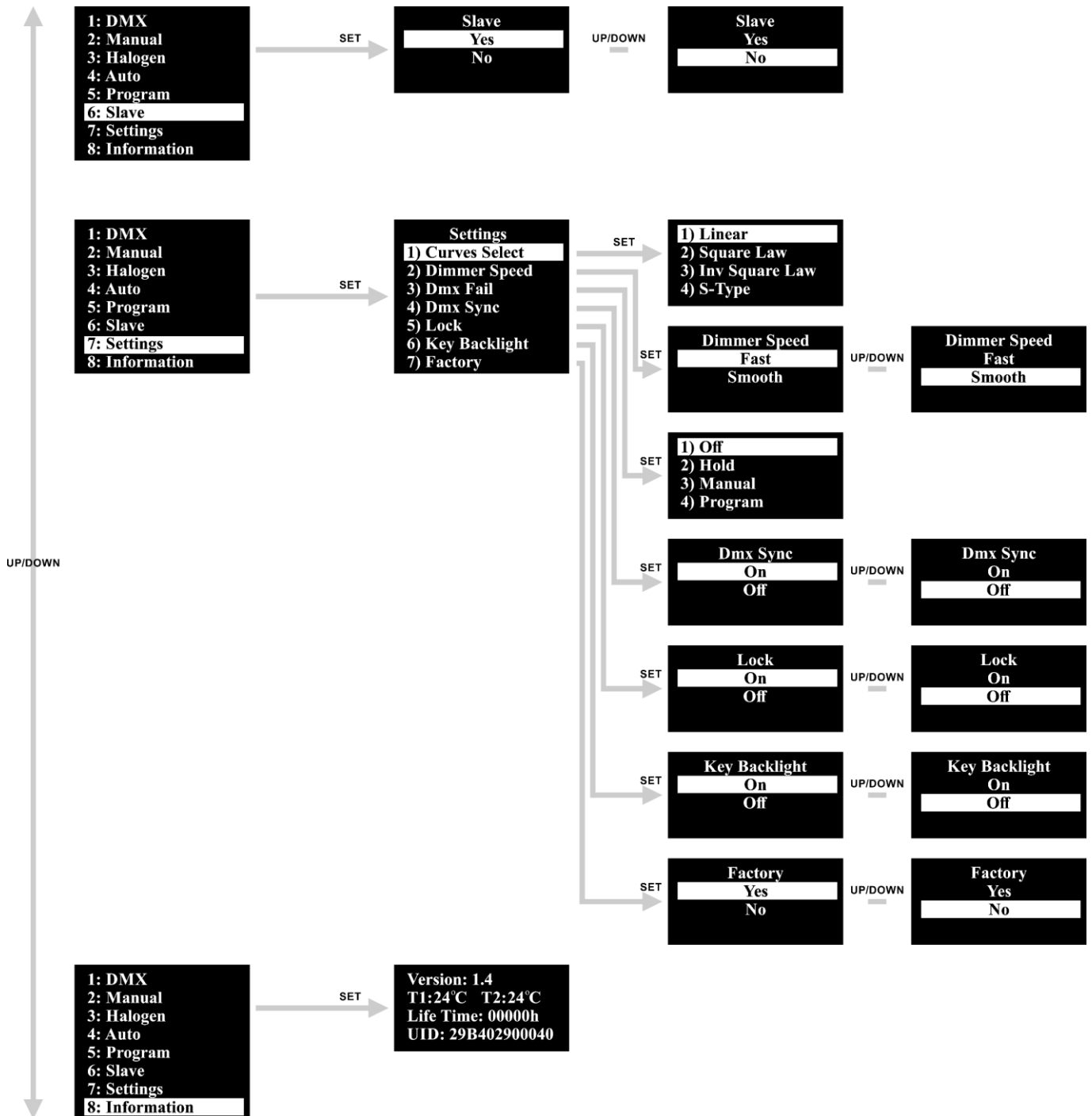

### Main Menu Options

01) Upon start-up, the display will show:



02) After 2 seconds, the display will show:

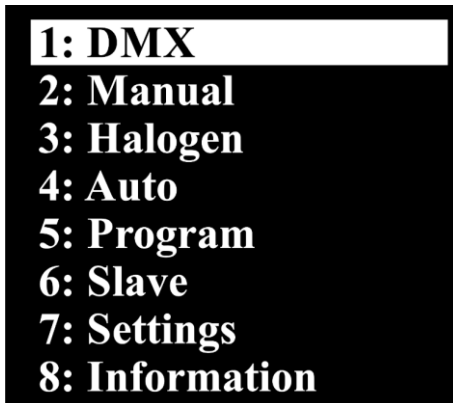

03) Press the **UP/DOWN** buttons to toggle through the menus.

04) Press the **SET** button to open the desired menu.

05) Press the **MODE** button to return to the previous screen.

#### 1. DMX Address/DMX Configuration

With this menu you can set the device's DMX starting address and choose a DMX channel mode.



01) While in the main menu, press the **UP/DOWN** buttons to choose DMX.

02) Press the **SET** button to open the menu.

03) Press the **UP/DOWN** buttons to choose ADDRESS or CHANNELS.

04) Once you have chosen ADDRESS, press the **SET** button to open the submenu.

05) Press the **UP/DOWN** buttons to set the desired DMX address. The adjustment range is between 001-512.

06) Once you have chosen CHANNELS, press the **SET** button to open the submenu.

07) Press the **UP/DOWN** buttons to choose 1, 4, 8 or 9 DMX channels.



### 2. Manual Color mode

With this menu you can set the static colors.

|                     |            |
|---------------------|------------|
| <b>1) C White1:</b> | <b>255</b> |
| <b>2) W White1:</b> | <b>255</b> |
| <b>3) C White2:</b> | <b>255</b> |
| <b>4) W White2:</b> | <b>255</b> |
| <b>5) R Ring:</b>   | <b>255</b> |
| <b>6) G Ring:</b>   | <b>255</b> |
| <b>7) B Ring:</b>   | <b>255</b> |

- 01) While in the main menu, press the **UP/DOWN** buttons to choose MANUAL.
- 02) Press the **SET** button to open the menu.
- 03) Press the **UP/DOWN** buttons to toggle through the static colors: Cold White (1-2), Warm White (1-2), Red, Green and Blue.
- 04) Once you have chosen the desired color, press the **SET** button to adjust the color intensity.
- 05) Press the **UP/DOWN** buttons to set the color intensity. The adjustment range is between 0-255, from dark to brightest.

### 3. Halogen

With this menu you can set the halogen function.

|                      |            |
|----------------------|------------|
| <b>1) Halogen 1:</b> | <b>255</b> |
| <b>2) Halogen 2:</b> | <b>255</b> |

- 01) While in the main menu, press the **UP/DOWN** buttons to choose HALOGEN.
- 02) Press the **SET** button to open this menu.
- 03) Press the **UP/DOWN** buttons to toggle through the 2 options: Halogen 1-2.
- 04) Once you have chosen the desired halogen, press the **SET** button to adjust the color intensity.
- 05) Press the **UP/DOWN** buttons to set the color intensity. The adjustment range is between 0-255, from dark to brightest.

### 4. Auto

With this menu, you can activate the auto show.

- 01) While in the main menu, press the **UP/DOWN** buttons to choose AUTO.
- 02) Press the **SET** button to open the menu. The display will show:

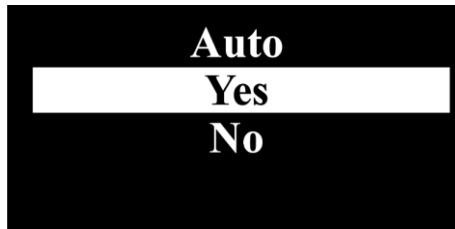

- 03) Press the **UP/DOWN** buttons to select YES or NO. Press the **SET** button to confirm your choice.
- 04) If you have chosen YES, the device will start the auto program.
- 05) If you have chosen NO, the device will keep its current settings.

### 5. Program

With this menu, you can set the preset colors or the program speed and the strobe frequency of the built-in programs.

- 01) While in the main menu, press the **UP/DOWN** buttons to choose PROGRAM.
- 02) Press the **SET** button to enter the menu. The display will show:

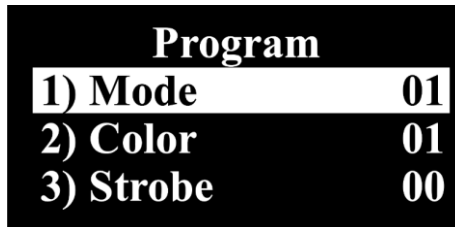

- 03) Press the **UP/DOWN** buttons to choose MODE and press the **SET** button to enter the menu.
- 04) The display will show:



- 05) Press the **UP/DOWN** buttons to choose one of the 8 built-in programs. Press the **SET** button to confirm your choice.

### 5.1. Program 1

01) If you have chosen program 01, the display will show:

| Program   |    |
|-----------|----|
| 1) Mode   | 01 |
| 2) Color  | 01 |
| 3) Strobe | 00 |

02) Press the **UP/DOWN** buttons to choose one of the 2 options:

- COLOR
- STROBE

03) Press the **SET** button to enter the desired menu.

04) If you have chosen COLOR, press the **UP/DOWN** buttons to choose one of the 14 color macros. Press the **SET** button to save your settings.

05) If you have chosen STROBE, press the **UP/DOWN** buttons to set the strobe frequency. The adjustment range is between 0-99, from OFF to high frequency. Press the **SET** button to save your settings.

### 5.2. Programs 2-8

01) If you have chosen one of the programs 02-08, the display will show:

| Program   |    |
|-----------|----|
| 1) Mode   | 02 |
| 2) Speed  | 01 |
| 3) Strobe | 00 |

02) Press the **UP/DOWN** buttons to choose one of the 2 options:

- SPEED
- STROBE

03) Press the **SET** button to enter the desired menu.

04) If you have chosen SPEED, press the **UP/DOWN** buttons to set the built-in program's speed. The adjustment range is between 1-100, from slow to fast. Press the **SET** button to save your settings.

05) If you have chosen STROBE, press the **UP/DOWN** buttons to set the strobe frequency. The adjustment range is between 0-99, from OFF to high frequency. Press the **SET** button to save your settings.

## 6. Master/Slave

With this menu, you can set the device as a slave.

01) While in the main menu, press the **UP/DOWN** buttons to choose SLAVE.

02) Press the **SET** button to enter the menu. The display will show:

| Slave |
|-------|
| Yes   |
| No    |

03) Press the **UP/DOWN** buttons to choose YES or NO.

04) Press the **SET** button to confirm your choice.

05) If you have chosen YES, the device will be set as a slave and will react the same as the master device.

## 7. Settings

With this menu you can set the device's settings.

- 01) While in the main menu, press the **UP/DOWN** buttons to choose SETTINGS.
- 02) Press the **SET** button to open the menu.
- 03) Press the **UP/DOWN** buttons to toggle through the following menus: CURVES SELECT, DIMMER SPEED, DMX FAIL, DMX SYNC, LOCK, KEY BACKLIGHT and FACTORY.

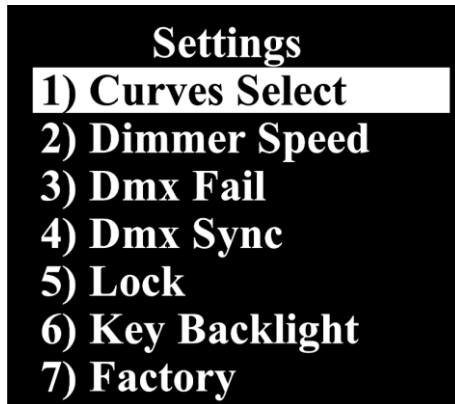

- 04) Press the **SET** button to open the menu.

### 7.1. Curves Select

With this menu, you can adjust the dimming of the device by choosing a dimming curve.

- 01) Press the **UP/DOWN** buttons to choose one of the 4 dimming curves:

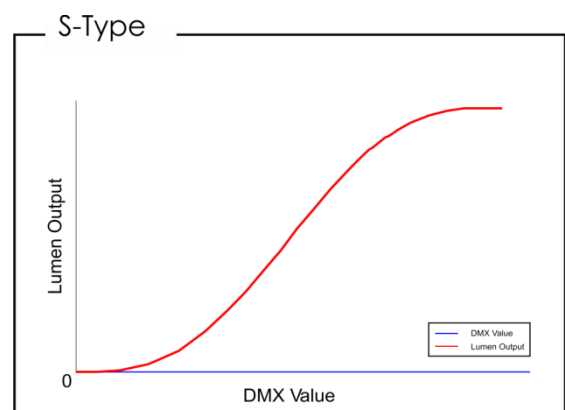
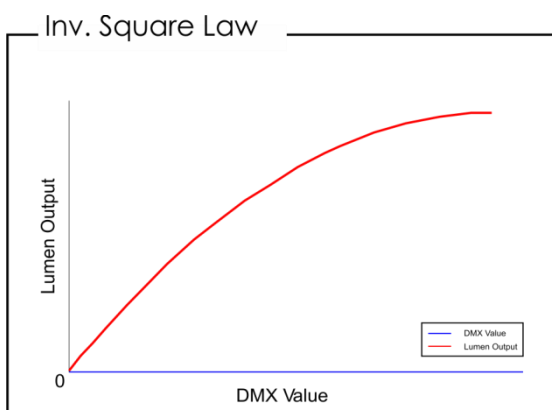
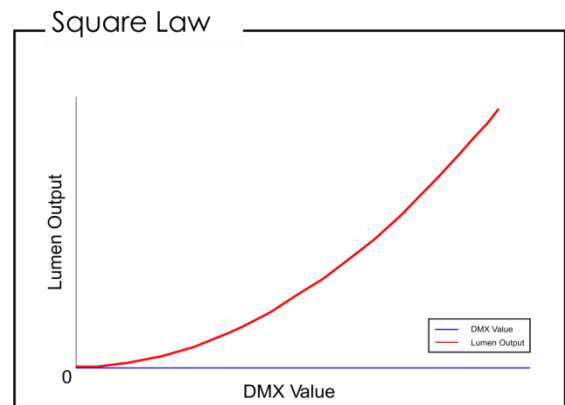
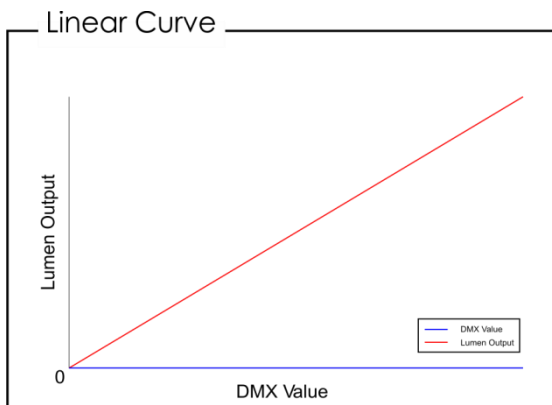

- 02) Press the **SET** button to confirm your choice.

### 7.2. Dimmer Speed

With this menu you can set the dimmer speed.

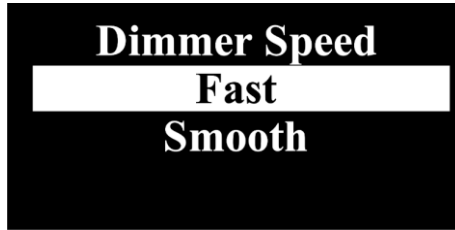

- 01) Press the **UP/DOWN** buttons to select FAST or SMOOTH.
- 02) Press the **SET** button to confirm your choice.

### 7.3. DMX Fail

With this menu you can set the device's behavior in case of a DMX failure.

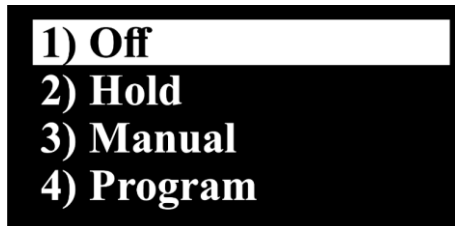

- 01) Press the **UP/DOWN** buttons to select one of the 4 options:
  - OFF: the device will black out the light output
  - HOLD: the device will use last properly received DMX signal, ensuring uninterrupted performance
  - MANUAL: the device will switch to Manual mode
  - PROGRAM: the device will run the built-in programs
- 02) Press the **SET** button to confirm your choice.

### 7.4. DMX Sync

With this menu you can set the devices' behavior, while using multiple Stage Blinders.



- 01) Press the **UP/DOWN** buttons to select ON (all Stage Blinders will simultaneously perform the same action, without any delays) or OFF (risk of random delays).
- 02) Press the **SET** button to confirm your choice.

### 7.5. Lock

With this menu you can set the safety lock, restricting access to the main menu.



- 01) Press the **UP/DOWN** buttons to select one of the 2 options:
  - ON: when no button is pressed within 30 seconds, the device's main menu will be locked.  
**In order to unlock it, press and hold down the MODE and SET buttons for 3 seconds.**
  - OFF: safety lock is inactive
- 02) Press the **SET** button to confirm your choice.

### 7.6. Key Backlight

With this menu you can set whether the 4 buttons (MODE, SET, UP, DOWN) will be illuminated or not.

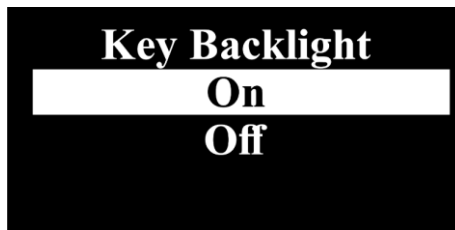

- 01) Press the **UP/DOWN** buttons to select ON or OFF.
- 02) Press the **SET** button to confirm your choice.

### 7.7. Factory

With this menu you can restore the default factory settings.



- 01) Press the **UP/DOWN** buttons to select YES or NO.
- 02) Press the **SET** button to confirm your choice.

### 8. Information

With this menu you can view the device's current software version, temperature, total lifetime and the device's UID number.

- 01) While in the main menu, press the **UP/DOWN** buttons to choose INFORMATION.
- 02) Press the **SET** button to enter the menu. The display will show:



## DMX Channels

### 1 Channel

#### Channel 1 – Tungsten intensity

0-255 Gradual adjustment Tungsten, from dark to brightest

### 4 Channels

#### Channel 1 – Tungsten intensity

0-255 Gradual adjustment Tungsten, from dark to brightest

#### Channel 2 – Red dimmer intensity

0-255 Gradual adjustment Red, from dark to brightest

#### Channel 3 – Green dimmer intensity

0-255 Gradual adjustment Green, from dark to brightest

#### Channel 4 – Blue dimmer intensity

0-255 Gradual adjustment Blue, from dark to brightest

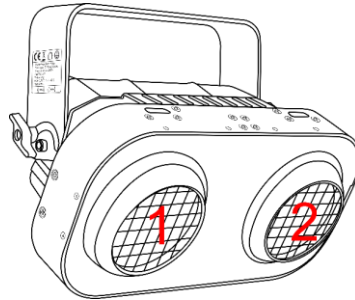

### 8 Channels

#### Channel 1 – Tungsten intensity POD 1

0-255 Gradual adjustment Tungsten, from dark to brightest

#### Channel 2 – Tungsten intensity POD 2

0-255 Gradual adjustment Tungsten, from dark to brightest

#### Channel 3 – Red dimmer intensity POD 1

0-255 Gradual adjustment Red, from dark to brightest

#### Channel 4 – Green dimmer intensity POD 1

0-255 Gradual adjustment Green, from dark to brightest

#### Channel 5 – Blue dimmer intensity POD 1

0-255 Gradual adjustment Blue, from dark to brightest

#### Channel 6 – Red dimmer intensity POD 2

0-255 Gradual adjustment Red, from dark to brightest

#### Channel 7 – Green dimmer intensity POD 2

0-255 Gradual adjustment Green, from dark to brightest

#### Channel 8 – Blue dimmer intensity POD 2

0-255 Gradual adjustment Blue, from dark to brightest

## 9 Channels

### Channel 1 – White dimmer intensity POD 1

0-255 Gradual adjustment White, from dark to brightest

### Channel 2 – Amber dimmer intensity POD 1

0-255 Gradual adjustment Amber, from dark to brightest

### Channel 3 – White dimmer intensity POD 2

0-255 Gradual adjustment White, from dark to brightest

### Channel 4 – Amber dimmer intensity POD 2

0-255 Gradual adjustment Amber, from dark to brightest

### Channel 5 – Strobe White/Amber

0-10 Closed

11-255 Strobe flash frequency, from low to high frequency (0-20 Hz)

### Channel 6 – Color presets

0-10 No function

11-28 Color 1 (R255, G000, B000)

29-46 Color 2 (R000, G255, B000)

47-64 Color 3 (R000, G000, B255)

65-82 Color 4 (R255, G150, B000)

83-100 Color 5 (R255, G180, B000)

101-118 Color 6 (R255, G255, B000)

119-136 Color 7 (R255, G000, B255)

137-154 Color 8 (R255, G000, B140)

155-172 Color 9 (R000, G255, B255)

173-190 Color 10 (R255, G100, B100)

191-208 Color 11 (R100, G255, B100)

209-226 Color 12 (R100, G255, B100)

227-244 Color 13 (R255, G200, B040)

245-255 Color 14 (R255, G255, B255)

### Channel 7 – Built-in programs

0-10 No function

11-45 Color switch 1

46-80 Color switch 2

81-115 Color switch 3

116-150 Color flow 1

151-185 Color flow 2

186-220 Color flow 3

221-255 Color flow 4

### Channel 8 – Speed Built-in programs CH7 must be set between 11-255

0-255 Speed adjustment, from slow to fast

### Channel 9 – Strobe RGB

0-10 Closed

11-255 Strobe flash frequency, from low to high frequency (0-20 Hz)



### Maintenance

---

The operator has to make sure that safety-related and machine-technical installations are to be inspected by an expert after every year in the course of an acceptance test.

The operator has to make sure that safety-related and machine-technical installations are to be inspected by a skilled person once a year.

The following points have to be considered during the inspection:

- 01) All screws used for installing the device or parts of the device have to be tightly connected and must not be corroded.
- 02) There may not be any deformations on housings, fixations and installation spots.
- 03) Mechanically moving parts like axles, eyes and others may not show any traces of wearing.
- 04) The electric power supply cables must not show any damages or material fatigue.

The Stage Blinder 2 Blaze requires almost no maintenance. However, you should keep the unit clean. Otherwise, the fixture's light output will be significantly reduced. Disconnect the mains power supply, and then wipe the cover with a damp cloth. Do not immerse in liquid. Wipe lens clean with glass cleaner and a soft cloth. Do not use alcohol or solvents.

The front lens will require weekly cleaning, as smoke-fluid tends to build up residues, reducing the light output very quickly.

Keep connections clean. Disconnect electric power, and then wipe the DMX connections with a damp cloth. Make sure connections are thoroughly dry before linking equipment or supplying electric power.

### Troubleshooting

---

#### No Light

If the light effect does not operate properly, refer servicing to a technician.

Suspect three potential problem areas as: the power supply, the LEDs or the internal fuse.

- 01) Power supply. Check that the unit is plugged into an appropriate power supply.
- 02) The LEDs. Return the Stage Blinder to your Showtec dealer.
- 03) The internal fuse. Return the Stage Blinder to your Showtec dealer.
- 04) If all appears to be O.K., plug the unit in again.
- 05) If you are unable to determine the cause of the problem, do not open the Stage Blinder, as this may damage the unit and the warranty will become void.
- 06) Return the device to your Showtec dealer.

#### No Response to DMX

Suspect the DMX cable or connectors, a controller malfunction, a light effect DMX card malfunction.

- 01) Check the DMX setting. Make sure that DMX addresses are correct.
- 02) Check the DMX cable: Unplug the unit; change the DMX cable; then reconnect to electrical power. Try your DMX control again.
- 03) Determine whether the controller or light effect is at fault. Does the controller operate properly with other DMX products? If not, take the controller in for repair. If so, take the DMX cable and the light effect to a qualified technician.

| Problem  | Probable cause(s)   | Remedy   |
|--|---|--|
| One or more fixtures do not function at all  | No power to the fixture   | <ul style="list-style-type: none"> <li>• Check if power is switched on and cables are plugged in</li> </ul>  |
|  | Internal fuse blown   | <ul style="list-style-type: none"> <li>• Return the device to your Showtec dealer</li> </ul>   |
| Fixtures reset correctly, but all respond erratically or not at all to the controller  | The controller is not connected   | <ul style="list-style-type: none"> <li>• Connect controller</li> </ul>   |
|  | 3-pin XLR Out of the controller does not match XLR Out of the first fixture on the link (i.e. signal is reversed) | <ul style="list-style-type: none"> <li>• Install a phase reversing cable between the controller and the first fixture on the link</li> </ul>   |
| Fixtures reset correctly, but some respond erratically or not at all to the controller | Poor data quality   | <ul style="list-style-type: none"> <li>• Check data quality. If much lower than 100 percent, the problem may be a bad data link connection, poor quality or broken cables, missing termination plug, or a defective fixture disturbing the link</li> </ul> |
|  | Bad data link connection  | <ul style="list-style-type: none"> <li>• Inspect connections and cables. Correct poor connections. Repair or replace damaged cables</li> </ul>   |
|  | Data link not terminated with 120 Ohm termination plug  | <ul style="list-style-type: none"> <li>• Insert termination plug in output jack of the last fixture on the link</li> </ul>   |
|  | Incorrect addressing of the fixtures  | <ul style="list-style-type: none"> <li>• Check address setting</li> </ul>  |
|  | One of the fixtures is defective and disturbs data transmission on the link                                       | <ul style="list-style-type: none"> <li>• Bypass one fixture at a time until normal operation is regained: unplug both connectors and connect them directly together</li> <li>• Have the defective fixture serviced by a qualified technician</li> </ul>    |
|  | 3-pin XLR Out on the fixtures does not match (pins 2 and 3 reversed)  | <ul style="list-style-type: none"> <li>• Install a phase-reversing cable between the fixtures or swap pin 2 and 3 in the fixture, that behaves erratically</li> </ul>  |
| No light or LEDs cut out intermittently  | Fixture is too hot  | <ul style="list-style-type: none"> <li>• Allow the fixture to cool down</li> <li>• Clean the fans</li> <li>• Make sure air vents are not blocked</li> <li>• Turn up the air conditioning</li> </ul>  |
|  | LEDs damaged  | <ul style="list-style-type: none"> <li>• Disconnect fixture and return to your dealer</li> </ul>   |
|  | The power supply settings do not match local AC voltage and frequency   | <ul style="list-style-type: none"> <li>• Disconnect fixture. Check settings and correct if necessary</li> </ul>  |

## Product Specifications

|  |   |
|--|---|
| Model:                                 | Showtec Stage Blinder 2 Blaze   |
| Input voltage:                         | 100-240V AC, 50/60Hz  |
| Power consumption:                     | 205W  |
| Dimensions:                            | 400 x 220 x 262 mm (LxWxH)  |
| Weight:                                | 7,3 kg  |
| <b>Operation and Programming</b>       |   |
| Signal pin OUT:                        | pin 1 earth, pin 2 (-), pin 3 (+)   |
| DMX channels:                          | 1, 4, 8, 9 channels   |
| Signal input:                          | 3-pin XLR IN  |
| Signal output:                         | 3-pin XLR OUT   |
| <b>Electro-mechanical effects</b>      |   |
| Light source:                          | 2 x 100W Dual-White COB, SMD RGB Blaze  |
| Color temperature:                     | 2100-3200K  |
| Refresh rate:                          | 4000Hz  |
| Pod movement:                          | +/- 20° stepless  |
| Beam angle:                            | 45°   |
| Field angle:                           | 84°   |
| IP rating:                             | IP65  |
| Housing:                               | Black powder-coated metal   |
| DMX control:                           | Via standard DMX controller   |
| Onboard:                               | OLED display for easy setup   |
| Control:                               | Auto, Built-in programs, Manual, Halogen, Master/Slave, DMX-512               |
| Dimmer:                                | 0-100%  |
| Strobe:                                | 0-20Hz  |
| Connections:                           | Pro power True 1 power connector IN/OUT IP65, 3-pin DMX connector IN/OUT IP65 |
| Cooling:                               | Cooling fans  |
| Max. ambient temperature $t_a$ :       | 40°C  |
| Max. housing temperature $t_B$ :       | 70°C  |
| <b>Minimum distance:</b>               |   |
| Min. distance from flammable surfaces: | 0,8 m   |
| Min. distance to lighted object:       | 0,8 m   |

Design and product specifications are subject to change without prior notice.



Website: [www.Showtec.info](http://www.Showtec.info)  
 Email: [service@highlite.com](mailto:service@highlite.com)

Dimensions

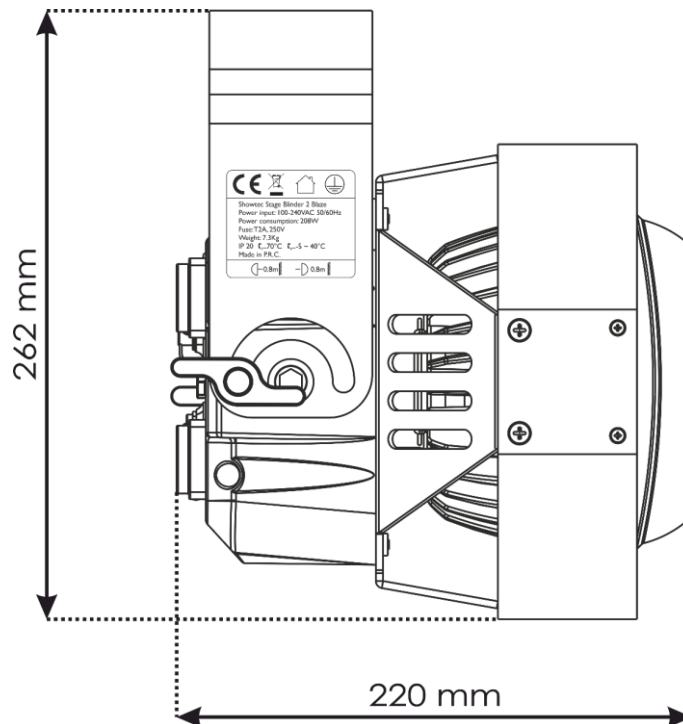
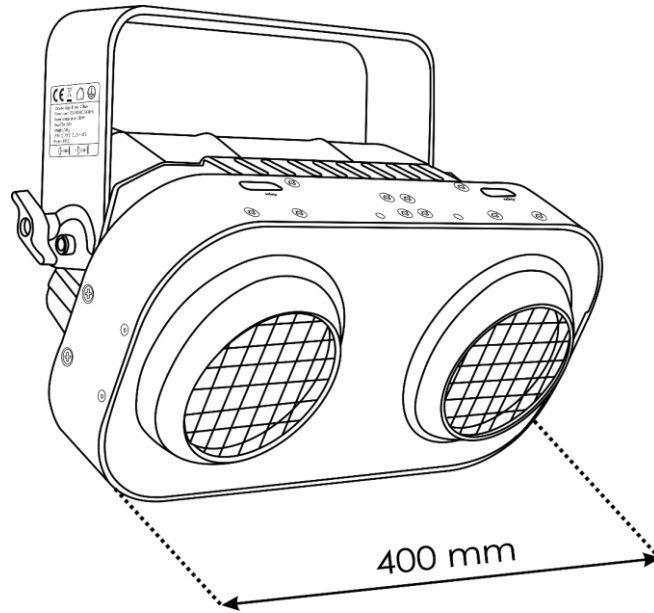









©2018 Showtec