

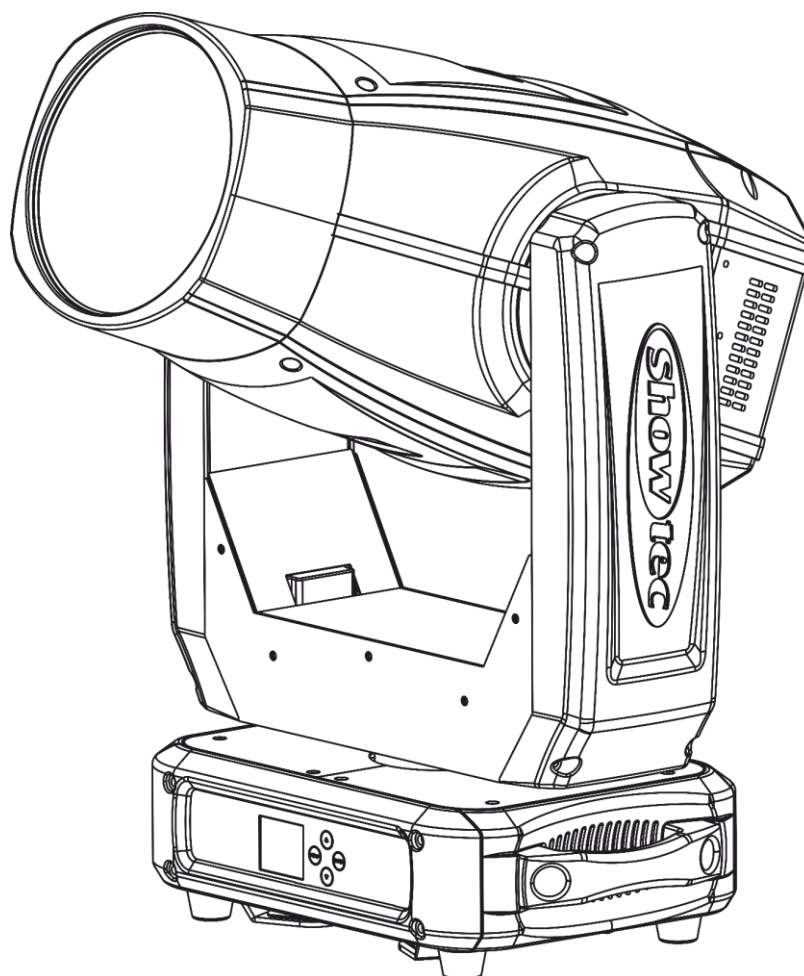

MANUAL



ENGLISH

Phantom 280 Hybrid

V1

Ordercode: 40078

Table of contents

Warning	2
Safety Instructions	2
Operating Determinations	4
Rigging	4
Connection with the mains.....	5
Return Procedure	5
Claims.....	5
 Description of the device	6
Features	6
Frontside.....	7
Backside	8
 Installation	8
 Setup and Operation	8
Control Modes.....	9
One Phantom (Auto, Manual)	9
One Phantom (Sound-controlled)	9
Multiple Phantoms (Master/Slave control)	9
Multiple Phantoms (DMX Control)	10
Fixture Linking.....	11
Data Cabling.....	11
Control Panel.....	12
Control Mode	12
DMX Addressing	12
Menu Overview	13
Main Menu Options	14
DMX Addressing	14
Built-in Programs Mode	15
1. DMX Mode	15
2. Slave Mode.....	15
3. Auto Mode.....	15
4. Sound-controlled Mode	15
5. Manual Mode	16
Advanced Settings.....	17
System Information	17
DMX Channels	18
13 Channels	18
18 Channels	21
 Maintenance	24
Replacing the Fuse	24
Replacing a Gobo From the Rotating Gobo Wheel	24
Glass Gobo Orientation.....	25
Rotating Gobo Wheel + Static Gobo Wheel + Color Wheel	26
 Troubleshooting	27
No Light	27
No Response to DMX.....	27
 Product Specifications	29
 Dimensions	30

Warning



**For your own safety, please read this user manual carefully
before your initial start-up!**



Unpacking Instructions

Immediately upon receiving this product, carefully unpack the carton and check the contents to ensure that all parts are present, and have been received in good condition. Notify the dealer immediately and retain packing material for inspection if any parts appear damaged from shipping or the carton itself shows signs of mishandling. Save the carton and all packing materials. In the event that a fixture must be returned to the factory, it is important that the fixture be returned in the original factory box and packing.

Your shipment includes:

- Showtec Phantom 280 Hybrid
- Pro power cable (1,5 m)
- 2 x quick lock brackets
- User manual

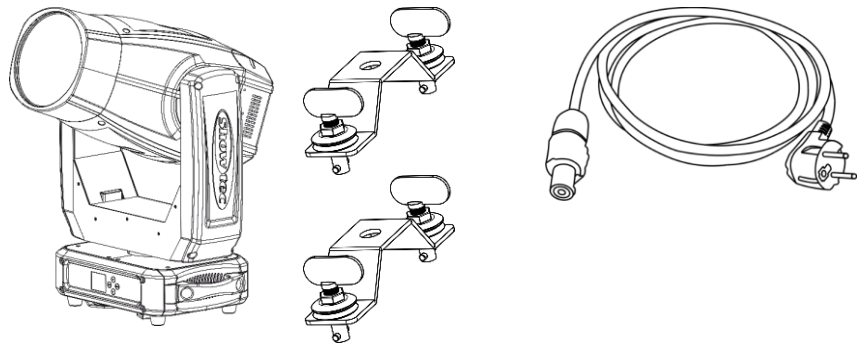

LED Expected Lifespan

LEDs gradually decline in brightness over time. HEAT is the dominant factor that leads to the acceleration of this decline. Packaged in clusters, LEDs exhibit higher operating temperatures than in ideal or singular optimum conditions. For this reason, when all color LEDs are used at their fullest intensity, life of the LEDs is significantly reduced. If improving the lifespan is of higher priority, place care in providing for lower operational temperatures. This may include climatic-environmental and the reduction of overall projection intensity.



CAUTION!

**Keep this device away from rain and moisture!
Unplug mains lead before opening the housing!**



Safety Instructions

Every person involved with the installation, operation and maintenance of this device has to:

- be qualified
- follow the instructions of this manual



**CAUTION! Be careful with your operations.
With a dangerous voltage you can suffer
a dangerous electric shock when touching the wires!**



Before the initial start-up, please make sure that there is no damage caused by transportation. Should there be any, consult your dealer and do not use the device.

To maintain perfect condition and to ensure a safe operation, it is absolutely necessary for the user to follow the safety instructions and warning notes contained in this manual.

Please consider that damages caused by manual modifications to the device are not subject to warranty.

This device contains no user-serviceable parts. Refer servicing to qualified technicians only.

IMPORTANT:

The manufacturer will not accept liability for any resulting damages caused by the non-observance of this manual or any unauthorized modification to the device.

- Never let the power cord come into contact with other cables! Handle the power cord and all connections with the mains with particular caution!
- Never remove warning or informative labels from the unit.
- Never use anything to cover the ground contact.
- Never lift the fixture holding it by the projector-head, as the mechanics may be damaged. Always hold the fixture by the transport handles.
- Never place any material over the LEDs or the lens.
- Never look directly into the light source.
- Never leave any cables lying around.
- Do not insert objects into air vents.
- Do not connect this device to a dimmer pack.
- Do not switch the device on and off in short intervals, as this will reduce the device's life.
- Do not touch the device's housing bare-handed during its operation (housing becomes very hot). Allow the fixture to cool for at least 5 minutes before handling.
- Do not shake the device. Avoid brute force when installing or operating the device.
- Only use the device indoors, avoid contact with water or other liquids.
- Only operate the fixture after having checked if the housing is firmly closed and all screws are tightly fastened.
- Only operate the device after having familiarized with its functions.
- Avoid flames and do not put close to flammable liquids or gases.
- Always keep the case closed while operating.
- Always allow a free air space of at least 80 cm around the unit for ventilation.
- Always disconnect power from the mains, when device is not used or before cleaning! Only handle the power cord holding it by the plug. Never pull out the plug by tugging the power cord.
- Make sure that the device is not exposed to extreme heat, moisture or dust.
- Make sure that the available voltage is not higher than stated on the rear panel.
- Make sure that the power cord is never crimped or damaged. Check the device and the power cord from time to time.
- If the lens is obviously damaged, it has to be replaced, so that its functions are not impaired due to cracks or deep scratches.
- If device was dropped or struck, disconnect mains power supply immediately. Have a qualified engineer inspect for safety before operating.
- If the device has been exposed to drastic temperature fluctuation (e.g. after transportation), do not switch it on immediately. The arising condensation water might damage your device. Leave the device switched off until it has reached room temperature.
- If your Showtec device fails to work properly, discontinue the use immediately. Pack the unit securely (preferably in the original packing material), and return it to your Showtec dealer for service.
- For adult use only. Moving head must be installed beyond the reach of children. Never leave the unit running unattended.
- Never attempt to bypass the thermostatic switch or fuses.
- For replacement use fuses of same type and rating only.
- The user is responsible for correct positioning and operating of the Phantom. The manufacturer will not accept liability for damages caused by the misuse or incorrect installation of this device.
- This device falls under protection class I. Therefore it is essential to connect the yellow/green conductor to earth.
- Repairs, servicing and electric connection must be carried out by a qualified technician.
- WARRANTY: Till one year after date of purchase.



CAUTION! Eyedamages!!!
Avoid looking directly into the lightsource!!!
(meant especially for epileptics)!!!



Operating Determinations

- This device is not designed for permanent operation. Consistent operation breaks will ensure that the device will serve you for a long time without defects.
- The minimum distance between light output and the illuminated surface must be bigger than 80 cm.
- To eliminate wear and improve lifespan, during periods of non-use, completely disconnect from power via breaker or by unplugging.
- The maximum ambient temperature $t_a = 40\text{ °C}$ must never be exceeded.
- The relative humidity must not exceed 50 % with an ambient temperature of 40 °C .
- If this device is operated in any other way than the one described in this manual, the product may suffer damages and the warranty becomes void.
- Any other operation may lead to dangers like short-circuit, burns, electric shock, crash, etc.

You endanger your own safety and the safety of others!

Rigging

Please follow the European and national guidelines concerning rigging, trussing and all other safety issues.

Do not attempt the installation yourself !

Always let the installation be carried out by an authorized dealer !

Procedure:

- If the Phantom is lowered from the ceiling or high joists, professional trussing systems have to be used.
- Use a clamp to mount the Phantom, with the mounting bracket, to the trussing system.
- The Phantom must never be fixed swinging freely in the room.
- The installation must always be secured with a safety attachment, e.g. an appropriate safety net or safety cable.
- When rigging, derigging or servicing the projector, always make sure, that the area below the installation site is secured and that there are not any unauthorized people around.

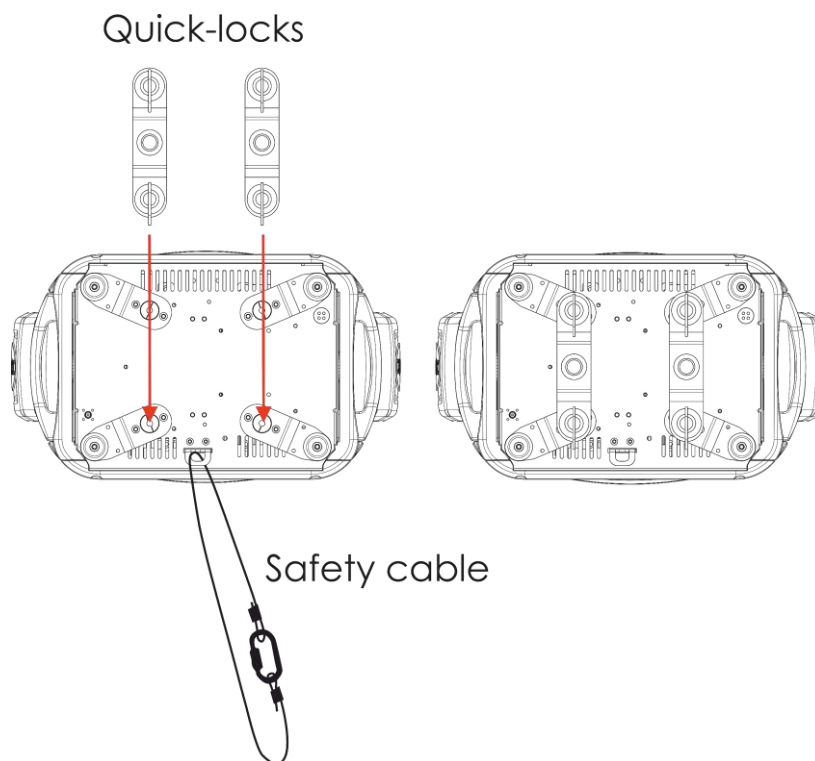

The Phantom can be placed on a flat stage floor or mounted to any kind of truss with quick locks and a clamp.

Improper installation can cause serious injuries and/or damage of property!

Connection with the mains

Connect the device to the mains with the power-plug.
Always check if the right color cable is connected to the right place.

International	EU Cable	UK Cable	US Cable	Pin
L	BROWN	RED	YELLOW/COPPER	PHASE
N	BLUE	BLACK	SILVER	NEUTRAL
	YELLOW/GREEN	GREEN	GREEN	PROTECTIVE GROUND

Make sure that the device is always properly connected to the earth!

Improper installation can cause serious injuries and/or damage of property!

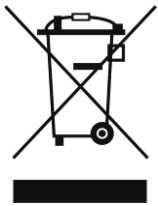

 Return Procedure 

Returned merchandise must be sent prepaid and in the original packing, call tags will not be issued. Package must be clearly labeled with a Return Authorization Number (RMA number). Products returned without an RMA number will be refused. Highlite will not accept the returned goods or any responsibility. Call Highlite 0031-455667723 or mail offersales@highlite.com and request an RMA prior to shipping the fixture. Be prepared to provide the model number, serial number and a brief description of the cause for the return. Be sure to properly pack fixture, any shipping damage resulting from inadequate packaging is the customer's responsibility. Highlite reserves the right to use its own discretion to repair or replace product(s). As a suggestion, proper UPS packing or double-boxing is always a safe method to use.

Note: If you are given an RMA number, please include the following information on a piece of paper inside the box:

- 01) Your name
- 02) Your address
- 03) Your phone number
- 04) A brief description of the symptoms

Claims

The client has the obligation to check the delivered goods immediately upon delivery for any shortcomings and/or visible defects, or perform this check after our announcement that the goods are at their disposal. Damage incurred in shipping is the responsibility of the shipper; therefore the damage must be reported to the carrier upon receipt of merchandise.

It is the customer's responsibility to report and submit claims with the shipper in the event that a fixture is damaged due to shipping. Transportation damage has to be reported to us within one day after receipt of the delivery.

Any return shipment has to be made post-paid at all times. Return shipments must be accompanied with a letter defining the reason for return shipment. Non-prepaid return shipments will be refused, unless agreed otherwise in writing.

Complaints against us must be prepared in writing or sent by fax within 10 working days after receipt of the invoice. After this period complaints will not be handled anymore.

Complaints will only then be considered if the client has so far complied with all parts of the agreement, regardless of the agreement from which the obligation is resulting.

Description of the device

Features

The Phantom 280 Hybrid is a moving head with high output and great effects.

- Input voltage: 100–240 V AC, 50/60 Hz (auto ranging)
- Power consumption: 395 W
- Light source: 280W White LED
- Light output: 83708 lux (3°) @ 5 m
- Dimmer: 0–100 % Mechanical
- Strobe: 0–20 Hz
- Focus: Motorized
- Zoom: Motorized
- Prism: 3-facet circular rotating prism
- Frost: Yes
- Beam angle: 3–25,4° (motorized)
- DMX control: via standard DMX controller
- DMX channels: 13, 18 channels
- Onboard: Full colour display for easy setup
- Built-in automatic programs + built-in sound-activated programs
- Pan: 0–540°, Tilt: 0–270°
- Pan/Tilt resolution: 16 bit
- Pan / Tilt movement blackout, User-selectable Pan / Tilt ranges, 540°/360°/180° Reverse Pan / Tilt movement
- Control: Auto, Manual, Sound-controlled, Master/Slave, DMX-512
- Static gobo wheel 1: 12 gobos + open
- Rotating gobo wheel: 1 glass gobo + 6 metal gobos open
- Gobo size: Glass gobo: 23,74 mm (gobo size); 17 mm (image diameter); 1,15 mm (gobo thickness)
Metal gobo: 23,94 mm (gobo size); 16 mm (image diameter); 0,45 mm (gobo thickness)
- Gobo function: Gobo-flow effect, Gobo shake
- Colours: 7 dichroic colors + white
- Colour effect: Split-colours, Rainbow-flow effect
- Housing: Metal & flame-retardant plastic
- Cooling: Cooling fan
- IP rating: IP20
- Color: Black
- Connection: 3-pin XLR IN/OUT, Pro power connector IN/OUT
- Fuse: F7AL/250V
- Max Ambient temp. 40°
- Minimum distance objects: 3m
- Dimensions: 367 x 211 x 610 mm (LxWxH)
- Weight: 19,14 kg

Frontside

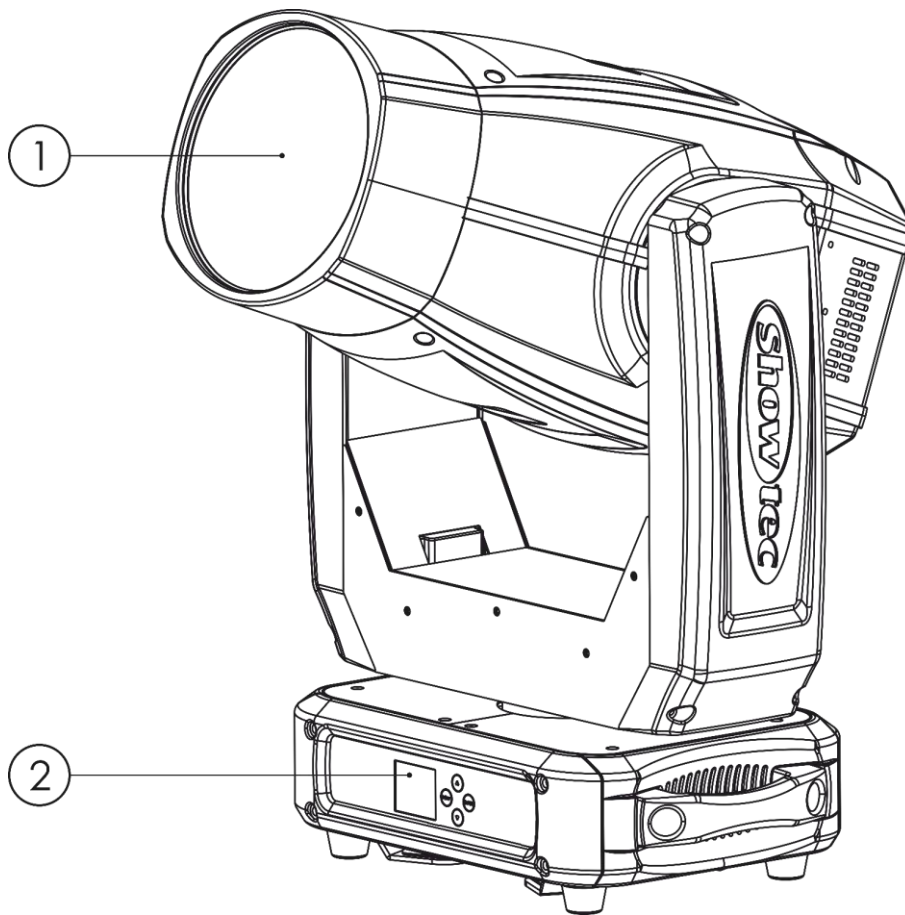

Fig. 01

- 01) Lens
- 02) Full colour display + control buttons

Backside

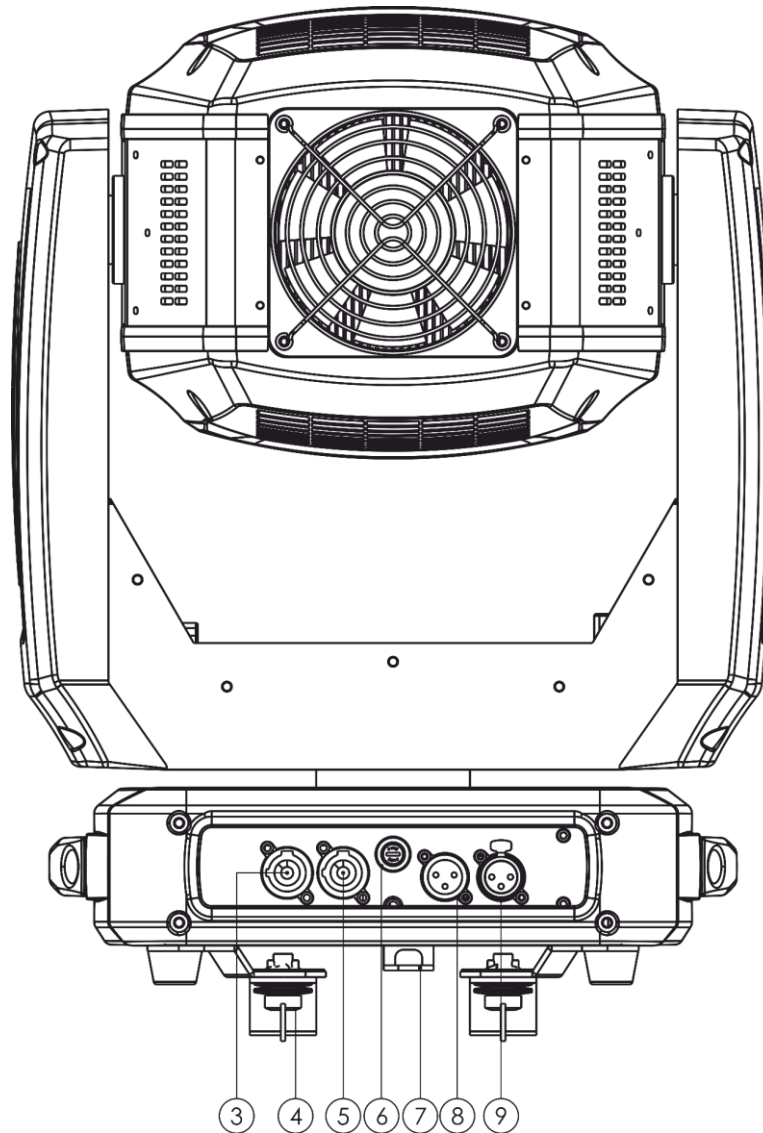

Fig. 02

- 03) 100–240 V Pro power connector IN (Blue)
- 04) Quick-lock
- 05) 100–240 V Pro power connector OUT (Gray)
- 06) Fuse F7AL/250V
- 07) Safety eye
- 08) 3-pin DMX signal connector IN
- 09) 3-pin DMX signal connector OUT

Installation

Remove all packing materials from the Phantom 280 Hybrid. Check if all foam and plastic padding is removed. Connect all cables.

Do not supply power before the whole system is set up and connected properly.

Always disconnect from electric mains power supply before cleaning or servicing.

Damages caused by non-observance are not subject to warranty.

Setup and Operation

Follow the directions below, as they pertain to your preferred operation mode.

Before plugging the unit in, always make sure that the power supply matches the product specification voltage. Do not attempt to operate a 110V specification product on 230V power, or vice versa.

Connect the device to the main power supply.

Control Modes

There are 5 modes:

- Auto
- Manual
- Sound-controlled
- Master/Slave
- DMX-512 (13CH, 18CH)

One Phantom (Auto, Manual)

- 01) Fasten the effect light to a firm trussing. Leave at least 0,8 meter on all sides for air circulation.
- 02) Always use a safety cable (ordercode 70140 / 70141).
- 03) Plug the end of the electric mains power cord into a proper electric power supply socket.
- 04) When the Phantom is not connected with a DMX cable, it functions as a stand-alone device. Please see pages 15–16 for more information about Auto mode and Manual mode.

One Phantom (Sound-controlled)

- 01) Fasten the effect light to a firm trussing. Leave at least 0,8 meter on all sides for air circulation.
- 02) Always use a safety cable (ordercode 70140 / 70141).
- 03) Plug the end of the electric mains power cord into a proper electric power supply socket.
- 04) Turn on the music. If the device is set to sound-control, then the Phantom will react to the beat of the music. Please see page 15 for more information about the sound-control options.

Multiple Phantoms (Master/Slave control)

- 01) Fasten the effect light onto firm trussing. Leave at least 0,8 meter on all sides for air circulation.
- 02) Always use a safety cable (ordercode 70140 / 70141).
- 03) Use a 3-pin XLR cable to connect the Phantom.

The pins:



- 01) Earth
- 02) Signal -
- 03) Signal +

- 04) Link the units as shown in fig. 03. Connect the first unit's DMX "out" socket with the second unit's "in" socket, using a DMX-signal cable. Repeat this process to link the second, third, and fourth units. You can use the same functions on the master device as described on page 15–16 (Auto mode, Manual mode or Sound-controlled mode). This means that you can set your desired operation mode on the master device and all slave devices will react the same as the master device.

Multiple Phantoms (Master/Slave control)

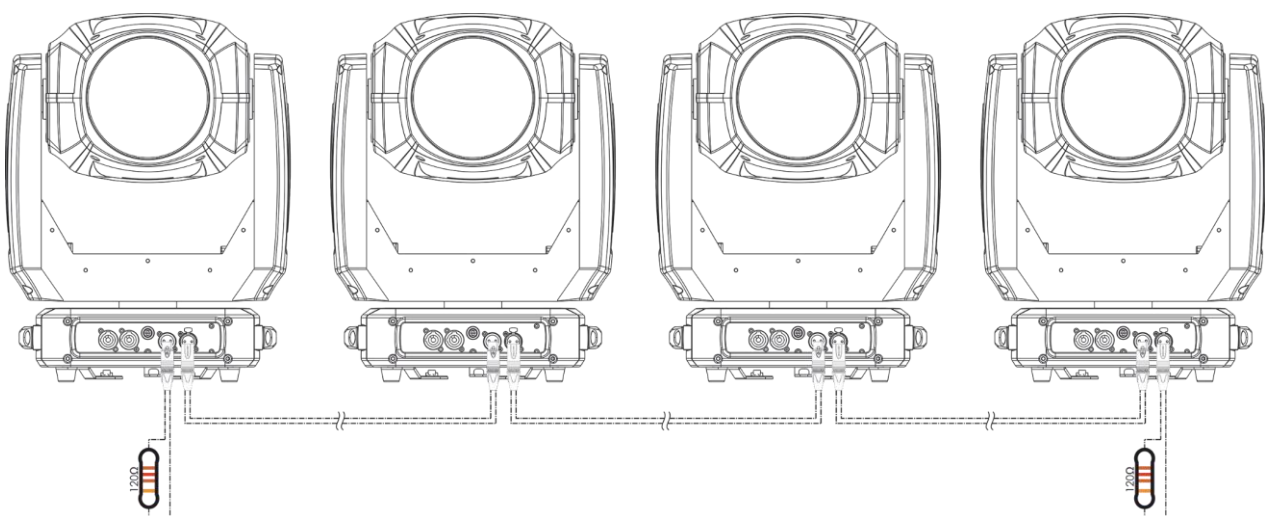
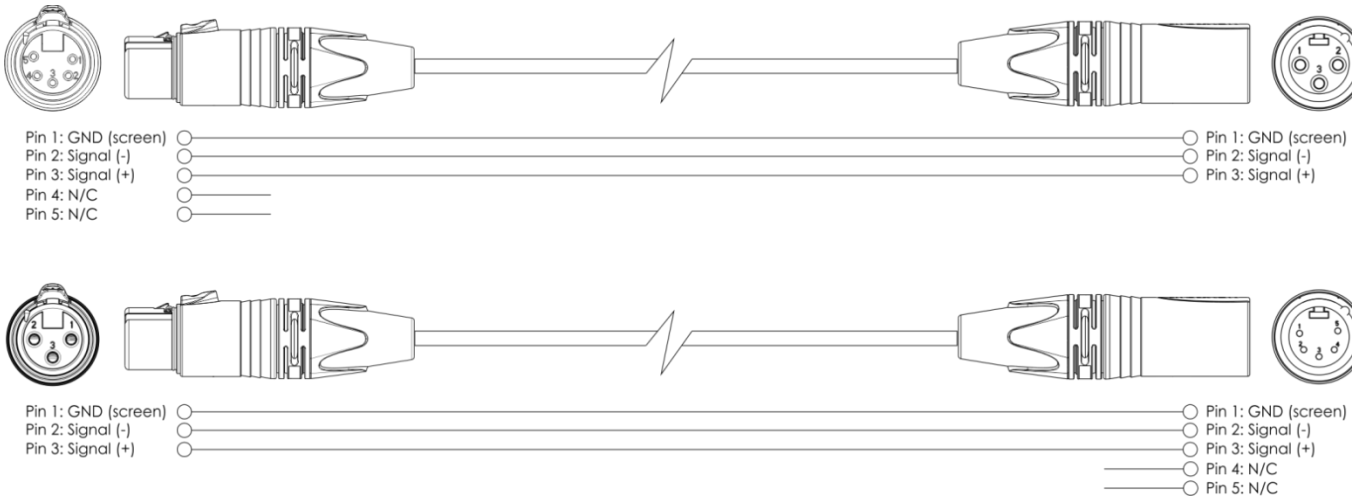

Fig. 03

Multiple Phantoms (DMX Control)

- 01) Fasten the effect light to a firm trussing. Leave at least 0,8 meter on all sides for air circulation.
- 02) Always use a safety cable (ordercode 70140 / 70141).
- 03) Use a 3-pin XLR cable to connect the Phantoms and other devices.



- 04) Link the units as shown in fig. 04. Connect the first unit's DMX "out" socket with the second unit's "in" socket, using a DMX signal cable. Repeat this process to link the second, third, and fourth units.
- 05) Supply electric power: Plug electric mains power cords into each unit's Pro power socket, then plug the other end of the mains power cord into proper electric power supply sockets, starting with the first unit. Do not supply power before the whole system is set up and connected properly.

Multiple Phantoms DMX Setup

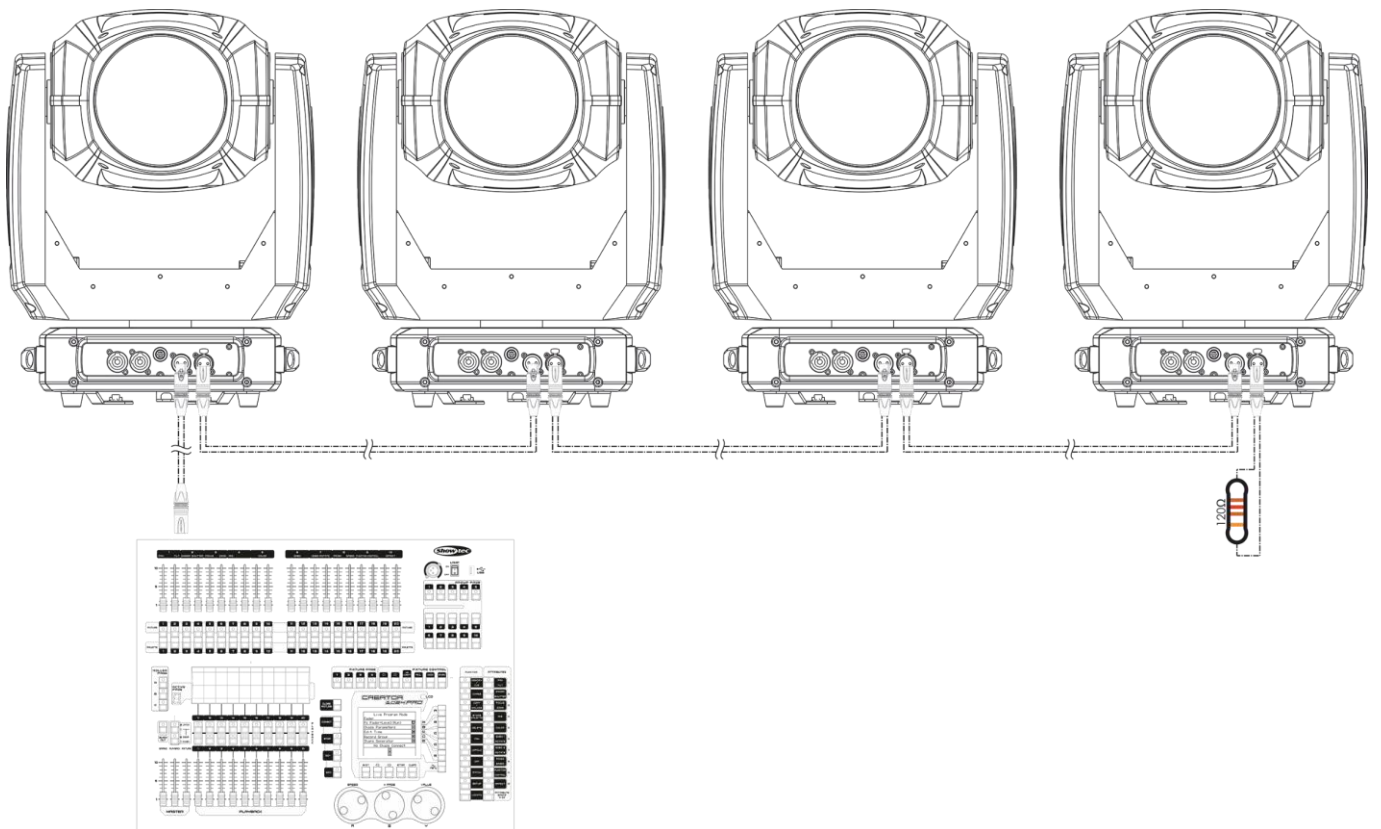



Fig. 04

Note : Link all cables before connecting electric power

Fixture Linking

You will need a serial data link to run light shows of one or more fixtures using a DMX-512 controller or to run synchronized shows of two or more fixtures set to a master/slave operating mode. The combined number of channels required by all the fixtures on a serial data link determines the number of fixtures the data link can support.

Important: Fixtures on a serial data link must be daisy-chained in a single line. To comply with the EIA-485 standard, no more than 30 devices should be connected on one data link. Connecting more than 30 fixtures on one serial data link without the use of a DMX optically isolated splitter may result in deterioration of the digital DMX signal.

 Maximum recommended DMX data link distance: 100 meters
Maximum recommended number of fixtures on a DMX data link: 30 fixtures
Maximum recommended number of fixtures on a power link @ 110V: 8 fixtures
Maximum recommended number of fixtures on a power link @ 230V: 17 fixtures

Data Cabling

To link fixtures together, you must obtain data cables. You can purchase DAP Audio certified DMX cables directly from a dealer/distributor or construct your own cable. If you choose to create your own cable, please use data-grade cables that can carry a high quality signal and are less prone to electromagnetic interference.

DAP Audio DMX Data Cables

- DAP Audio Basic microphone cable for allround use. bal. XLR/M 3-pin > XLR/F 3-pin. **Ordercode** FL01150 (1,5 m), FL013 (3 m), FL016 (6 m), FL0110 (10 m), FL0115 (15 m), FL0120 (20 m).
- DAP Audio X-type data cable XLR/M 3-pin > XLR/F 3-pin. **Ordercode** FLX0175 (0,75 m), FLX01150 (1,5 m), FLX013 (3 m), FLX016 (6 m), FLX0110 (10 m).
- DAP Audio cable for the demanding user with exceptional audio-qualities and connector made by Neutrik®. **Ordercode** FL71150 (1,5 m), FL713 (3 m), FL716 (6 m), FL7110 (10 m).
- DAP Audio cable for the demanding user with exceptional audio-qualities and connector made by Neutrik®. **Ordercode** FL7275 (0,75 m), FL72150 (1,5 m), FL723 (3 m), FL726 (6 m), FL7210 (10 m).
- DAP Audio 110 Ohm cable with digital signal transmission. **Ordercode** FL0975 (0,75 m), FL09150 (1,5 m), FL093 (3 m), FL096 (6 m), FL0910 (10 m), FL0915 (15 m), FL0920 (20 m).
- DAP Audio data cable FL08 DMX/AES-EBU, XLR/M 5-pin > XLR/F 5-pin. **Ordercode** FL08150 (1,5 m), FL083 (3 m), FL086 (6 m), FL0810 (10 m), FL0820 (20 m).
- DAP Audio DMX adapter: 5-pin/3-pin. **Ordercode** FLA29.
- DAP Audio DMX adapter: 3-pin/5-pin. **Ordercode** FLA30.
- DAP Audio DMX Terminator 3-pin. **Ordercode** FLA42.
- DAP Audio DMX Terminator 5-pin. **Ordercode** FLA43.

The Phantom 280 Hybrid can be operated with a controller in **control mode** or without the controller in **stand-alone mode**.

Control Panel

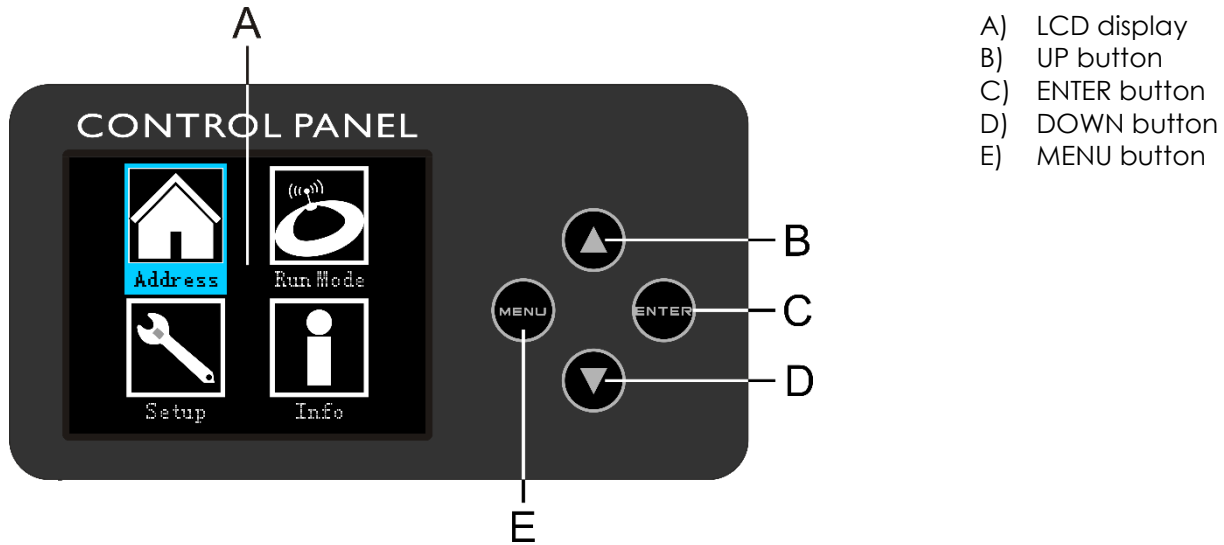

Fig. 05

Control Mode

The fixtures are individually addressed on a data-link and connected to the controller. The fixtures respond to the DMX signal from the controller. (When you select the DMX address and save it, the controller will display the saved DMX address, next time.)

DMX Addressing

The control panel on the front side of the base allows you to assign DMX fixture addresses, which is the first channel with which the Phantom will respond to the controller.

Please note, when you use the controller, the unit has **18** channels.

When using multiple Phantoms, make sure you set the DMX addresses right.

Therefore, the DMX address of the first Phantom should be **1(001)**; the DMX address of the second Phantom should be **1+18=19 (019)**; the DMX address of the third Phantom should be **19+18=37 (037)**, etc. Please, be sure that you do not have any overlapping channels in order to control each Phantom correctly. If two or more Phantoms are addressed similarly, they will work similarly.

Controlling:

After having addressed all Phantom fixtures, you may now start operating these via your lighting controller.

Note: After switching on, the Phantom will automatically detect whether DMX 512 data is received or not. If there is no data received at the DMX-input, the "LED" on the control panel will not flash.

If not, the problem may be:

- The XLR cable from the controller is not connected with the input of the Phantom 65.
- The controller is switched off or defective, the cable or connector is defective, or the signal wires are swapped in the input connector.

Note: It is necessary to insert an XLR termination plug (with 120 Ohm) in the last fixture in order to ensure proper transmission on the DMX data link.

Display Off after 30 seconds

When no button is pressed for 30 seconds, the display will turn off. To light up the display, you have to press the MENU, UP, DOWN or ENTER button. Once you have pressed the button, the display will light up.

Menu Overview

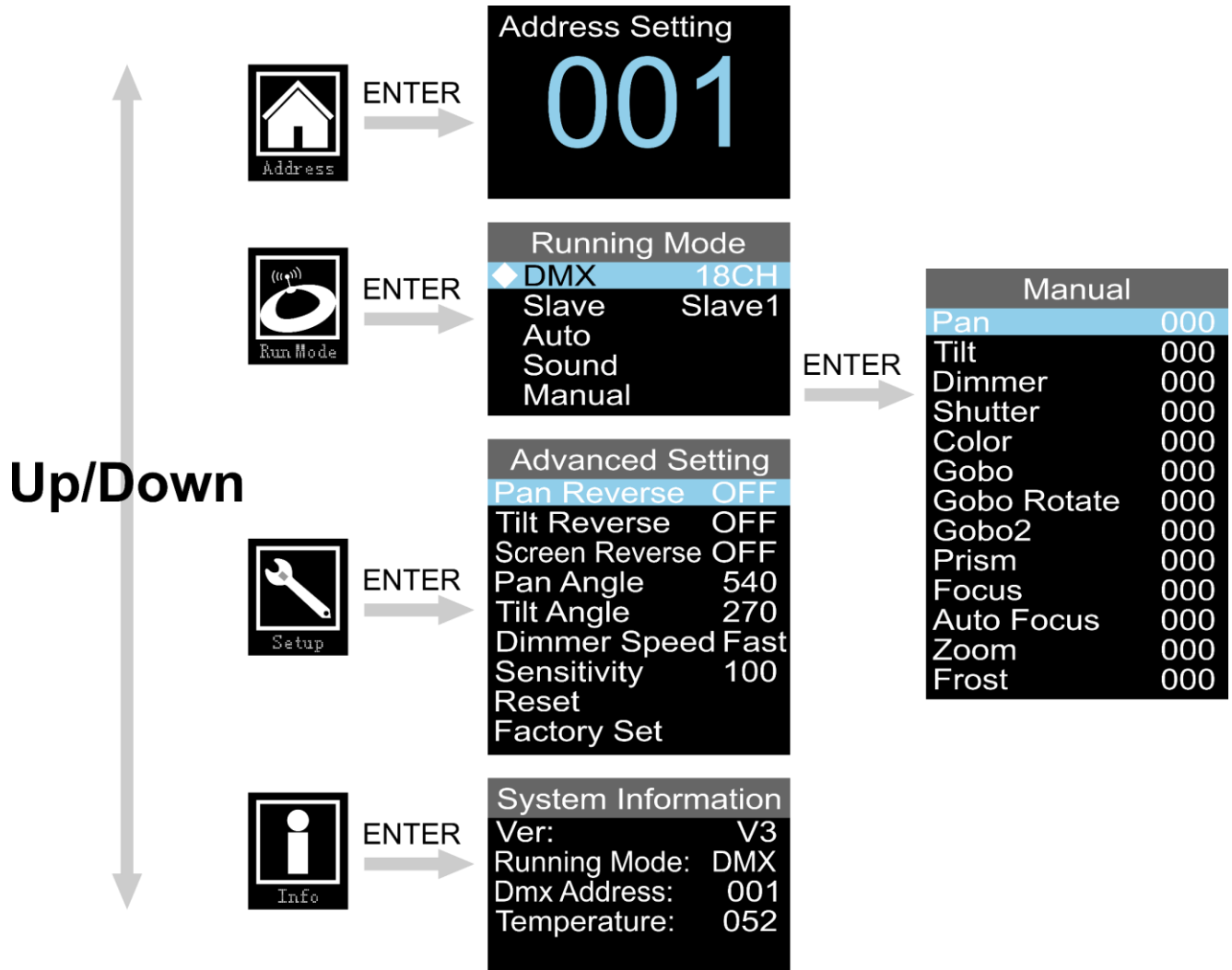

Main Menu Options



DMX Addressing



DMX mode / Master-Slave / Auto / Sound-controlled / Manual



Pan and Tilt Reverse / Screen Reverse / Pan and Tilt Angle / Fans / Dimmer Curve / Color Balance / Sound Sensitivity / Reset / Factory Reset



System Information

Upon start-up, the device will show its currently active mode, as well as the current Pan/Tilt settings. Press the **UP**, **DOWN**, **MENU** or **ENTER** button to open the main menu.



DMX Addressing

With this menu you can set the DMX address.



- 01) Press the **UP/DOWN** buttons, until the display shows **Address**.
- 02) Press the **ENTER** button to confirm. You can choose 512 different DMX addresses.
- 03) Press the **UP/DOWN** buttons to select the required address between 001–512.
- 04) Press the **ENTER** button to confirm the address.

Built-in Programs Mode

You can run the auto programs when using the Phantom.



- 01) While in the main menu, press the **UP/DOWN** buttons until the display shows
- 02) Press the **ENTER** button to open the menu.
- 03) Press the **UP/DOWN** buttons to select one of the 5 modes:

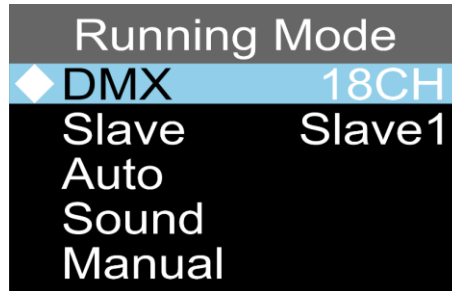

1. DMX Mode

- 01) When the display shows DMX, press the **ENTER** button to open the menu.
- 02) Press the **UP/DOWN** buttons to toggle between the 2 channel modes:
 - 13 channels
 - 18 channels
- 03) Press the **ENTER** button to confirm your choice.

2. Slave Mode

- 01) Press the **UP/DOWN** buttons until the display shows SLAVE.
- 02) Press the **ENTER** button to open the menu.
- 03) Press the **UP/DOWN** buttons to assign one of the 4 slave groups (Slave1–Slave4) to your slave device. Each slave group reacts differently to the signal from the master device.
- 04) Press the **ENTER** button to save changes.
- 05) The device is now operating in Slave mode. It means that it will react to the signal from the master device. You can connect up to 32 slave devices to one master device.

3. Auto Mode

- 01) Press the **UP/DOWN** buttons until the display shows AUTO.
- 02) Press the **ENTER** button to activate Auto mode.
- 03) The device will now run the built-in auto show.

4. Sound-controlled Mode

- 01) Press the **UP/DOWN** buttons until the display shows SOUND.
- 02) Press the **ENTER** button to activate Sound-controlled mode.
- 03) The device will now react to the beat of the background music by means of the built-in microphone.

5. Manual Mode

- 01) Press the **UP/DOWN** buttons until the display shows MANUAL.
- 02) Press the **ENTER** button to activate Manual mode.
- 03) The display will show:

Manual	
Pan	000
Tilt	000
Dimmer	000
Shutter	000
Color	000
Gobo	000
Gobo Rotate	000
Gobo2	000
Prism	000
Focus	000
Auto Focus	000
Zoom	000
Frost	000

- 04) Press the **UP/DOWN** buttons to choose one of the following options:
 - Pan (Pan position: 0–540°)
 - Tilt (Tilt position: 0–270°)
 - Dimmer (From dark to brightest)
 - Shutter
 - Color
 - Gobo
 - Gobo Rotate
 - Gobo2
 - Prism
 - Focus
 - Auto Focus
 - Zoom
 - Frost
- 05) Press the **ENTER** button to edit the desired option. The adjustment range for each option is between 0–255.
- 06) Press the **UP/DOWN** buttons to set the value.
- 07) Press the **ENTER** button to save changes.
- 08) The options correspond with the functions described in the DMX charts, pages 18–24.

Advanced Settings



- 01) While in the main menu, press the **UP/DOWN** buttons until the display shows
- 02) Press the **ENTER** button to open the menu.
- 03) The display will show:

Advanced Setting	
Pan Reverse	OFF
Tilt Reverse	OFF
Screen Reverse	OFF
Pan Angle	540
Tilt Angle	270
Dimmer Speed	Fast
Sensitivity	100
Reset	
Factory Set	

- 04) Press the **UP/DOWN** buttons to toggle through the following options:
 - Pan Reverse (ON/OFF)
 - Tilt Reverse (ON/OFF)
 - Screen Reverse (ON/OFF)
 - Pan Angle (180°/360°/540°)
 - Tilt Angle (90°/180°/270°)
 - Dimmer Speed (Smooth/Fast)
 - Sensitivity (001–100, from low to high sound sensitivity)
 - Reset (Pan/Tilt reset)
 - Factory Set (Full reset, restores factory default settings)
- 05) Press the **ENTER** button to edit the desired option.
- 06) Press the **UP/DOWN** buttons to set the value.
- 07) Press the **ENTER** button to save changes.

System Information

In this menu you can see the currently active mode, the DMX starting address, the current software version and the temperature of the device.



- 01) While in the main menu, press the **UP/DOWN** buttons until the display shows
- 02) Press the **ENTER** button to open the menu and view the parameters.

System Information	
Ver:	V3
Running Mode:	DMX
Dmx Address:	001
Temperature:	052

DMX Channels

13 Channels

Channel 1 – Horizontal movement (Pan)

Move the fader up, in order to move head horizontally (PAN).
 Gradual head adjustment from one end of the slider to the other (0–255, 128-center).
 The head can be turned by 540° and stopped at any position you wish.

Channel 2 – Vertical movement (Tilt)

Move the fader up, in order to move head vertically (TILT).
 Gradual head adjustment from one end of the slider to the other (0–255, 128-center).
 The head can be turned by 270° and stopped at any position you wish.

Channel 3 – Dimmer ⚠ CH4 must be open ⚠

0–255 From dark to brightest

Channel 4 – shutter/Strobe ⚠ CH3 must be open ⚠

0–3	Off
4–7	Shutter open
8–76	Synchronized strobe, from low to high frequency
77–145	Pulse strobe, from low to high frequency
146–215	Random strobe, from low to high frequency
216–255	Shutter open

Channel 5 – Color wheel

Linear color change following the movement of the slider. Between 190-221 and 224-255, the color wheel rotates continuously (so-called “Rainbow” effect).

0-7	Open / White
8-15	Red
16-23	Yellow
24-31	Green
32-39	Orange
40-47	Pink
48-55	Light green
56-63	Blue
64-68	Open / White
69-184	Gradual split-colors
185-189	Open / White
190-221	Clockwise rotation (CW) rainbow effect from fast to slow
222-223	Stop
224-255	Counterclockwise rotation (CCW) rainbow effect from slow to fast

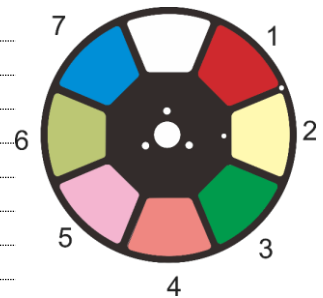

Channel 6 – Rotating gobo wheel + gobo shake

Linear gobo change following the movement of the slider. Between 128-189 and 194-255, the gobo wheel rotates continuously (so-called "Rainbow" effect).

0-7	Open / White
8-15	Gobo 1
16-23	Gobo 2
24-31	Gobo 3
32-39	Gobo 4
40-47	Gobo 5
48-55	Gobo 6
56-63	Gobo 7
64-71	Gobo 7 shaking, with increasing speed
72-79	Gobo 6 shaking, with increasing speed
80-87	Gobo 5 shaking, with increasing speed
88-95	Gobo 4 shaking, with increasing speed
96-103	Gobo 3 shaking, with increasing speed
104-111	Gobo 2 shaking, with increasing speed
112-119	Gobo 1 shaking, with increasing speed
120-127	Open / White
128-189	Positive rainbow effect with increasing speed
190-193	Stop
194-255	Negative rainbow effect with increasing speed

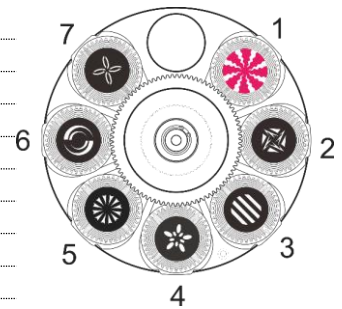

Channel 7 – Gobo rotation

0-63	Gobo indexing
64-145	Clockwise rotation (CW), from slow to fast
146-149	Stop
150-231	Counterclockwise rotation (CCW), from slow to fast
232-255	Gobo bouncing, from quick short bounce to longer rotation bounce

Channel 8 – Static gobo wheel + gobo shake

0-15	Open / White
16-19	Gobo 1
20-23	Gobo 2
24-27	Gobo 3
28-31	Gobo 4
32-35	Gobo 5
36-39	Gobo 6
40-43	Gobo 7
44-47	Gobo 8
48-51	Gobo 9
52-55	Gobo 10
56-59	Gobo 11
60-63	Gobo 12
64-67	Gobo Shake 12 from slow to fast
68-71	Gobo Shake 11 from slow to fast
72-75	Gobo Shake 10 from slow to fast
76-79	Gobo Shake 9 from slow to fast
80-83	Gobo Shake 8 from slow to fast
84-87	Gobo Shake 7 from slow to fast
88-91	Gobo Shake 6 from slow to fast
92-95	Gobo Shake 5 from slow to fast
96-99	Gobo Shake 4 from slow to fast
100-103	Gobo Shake 3 from slow to fast
104-107	Gobo Shake 2 from slow to fast
108-111	Gobo Shake 1 from slow to fast
112-127	Open / White
128-189	Clockwise rotation (CW) rainbow effect, from slow to fast
190-193	Stop
194-255	Counterclockwise rotation (CCW) rainbow effect, from slow to fast

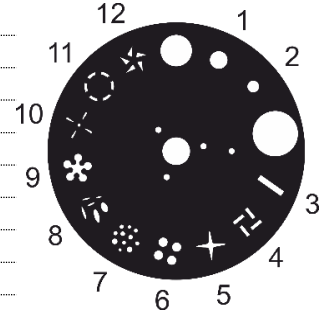

Channel 9 – Prism + rotation

0-7	Not functional
8-12	3-facet prism effect
13-130	Clockwise rotation (CW) 3-facet prism effect, from slow to fast
131-247	Counterclockwise rotation (CCW) 3-facet prism effect, from slow to fast
252-255	3-facet prism effect

Channel 10 – Focus

0-255	Continuous adjustment
-------	-----------------------

Channel 11 – Zoom

0-255	Continuous adjustment, from big to small
-------	--

Channel 12 – Frost

0-4	No function
5-255	Frost effect

Channel 13 – Pan/Tilt built-in programs + sound-controlled programs

0-7	No Function
8-23	Built-in program 1
24-39	Built-in program 2
40-55	Built-in program 3
56-71	Built-in program 4
72-87	Built-in program 5
88-103	Built-in program 6
104-119	Built-in program 7
120-135	Built-in program 8
136-151	Sound-controlled program 1
152-167	Sound-controlled program 2
168-183	Sound-controlled program 3
184-199	Sound-controlled program 4
200-215	Sound-controlled program 5
216-231	Sound-controlled program 6
232-247	Sound-controlled program 7
248-255	Sound-controlled program 8

18 Channels

Channel 1 – Horizontal movement (Pan)

Move the fader up, in order to move head horizontally (PAN).
Gradual head adjustment from one end of the slider to the other (0–255, 128-center).
The head can be turned by 540° and stopped at any position you wish.

Channel 2 – Vertical movement (Tilt)

Move the fader up, in order to move head vertically (TILT).
Gradual head adjustment from one end of the slider to the other (0–255, 128-center).
The head can be turned by 270° and stopped at any position you wish.

Channel 3 – Pan fine 16 bit

Channel 4 – Tilt fine 16 bit

Channel 5 – PAN/TILT Speed

0–255 From Max Speed (0) to Min. Speed (255)

Channel 6 – Dimmer ⚠ CH7 must be open ⚠

0–255 From dark to brightest

Channel 7 – shutter/Strobe ⚠ CH6 must be open ⚠

0–3 Off
4–7 Shutter open
8–76 Synchronized strobe, from low to high frequency
77–145 Pulse strobe, from low to high frequency
146–215 Random strobe, from low to high frequency
216–255 Shutter open

Channel 8 – Color wheel

Linear color change following the movement of the slider. Between 190-221 and 224-255, the color wheel rotates continuously (so-called “Rainbow” effect).

0-7 Open / White
8-15 Red
16-23 Yellow
24-31 Green
32-39 Orange
40-47 Pink
48-55 Light green
56-63 Blue
64-68 Open / White
69-184 Gradual split-colors
185-189 Open / White
190-221 Clockwise rotation (CW) rainbow effect from fast to slow
222-223 Stop
224-255 Counterclockwise rotation (CCW) rainbow effect from slow to fast

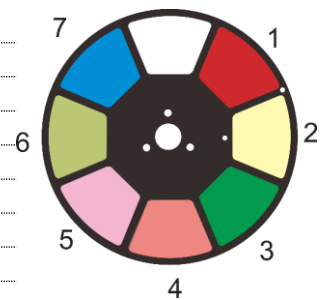

Channel 9 – Rotating gobo wheel + gobo shake

Linear gobo change following the movement of the slider. Between 128-189 and 194-255, the gobo wheel rotates continuously (so-called "Rainbow" effect).

0-7	Open / White
8-15	Gobo 1
16-23	Gobo 2
24-31	Gobo 3
32-39	Gobo 4
40-47	Gobo 5
48-55	Gobo 6
56-63	Gobo 7
64-71	Gobo 7 shaking, with increasing speed
72-79	Gobo 6 shaking, with increasing speed
80-87	Gobo 5 shaking, with increasing speed
88-95	Gobo 4 shaking, with increasing speed
96-103	Gobo 3 shaking, with increasing speed
104-111	Gobo 2 shaking, with increasing speed
112-119	Gobo 1 shaking, with increasing speed
120-127	Open / White
128-189	Positive rainbow effect with increasing speed
190-193	Stop
194-255	Negative rainbow effect with increasing speed

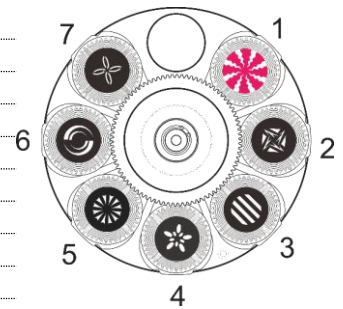

Channel 10 – Gobo rotation

0-63	Gobo indexing
64-145	Clockwise rotation (CW), from slow to fast
146-149	Stop
150-231	Counterclockwise rotation (CCW), from slow to fast
232-255	Gobo bouncing, from quick short bounce to longer rotation bounce

Channel 11 – Static gobo wheel + gobo shake

0-15	Open / White
16-19	Gobo 1
20-23	Gobo 2
24-27	Gobo 3
28-31	Gobo 4
32-35	Gobo 5
36-39	Gobo 6
40-43	Gobo 7
44-47	Gobo 8
48-51	Gobo 9
52-55	Gobo 10
56-59	Gobo 11
60-63	Gobo 12
64-67	Gobo Shake 12 from slow to fast
68-71	Gobo Shake 11 from slow to fast
72-75	Gobo Shake 10 from slow to fast
76-79	Gobo Shake 9 from slow to fast
80-83	Gobo Shake 8 from slow to fast
84-87	Gobo Shake 7 from slow to fast
88-91	Gobo Shake 6 from slow to fast
92-95	Gobo Shake 5 from slow to fast
96-99	Gobo Shake 4 from slow to fast
100-103	Gobo Shake 3 from slow to fast
104-107	Gobo Shake 2 from slow to fast
108-111	Gobo Shake 1 from slow to fast
112-127	Open / White
128-189	Clockwise rotation (CW) rainbow effect, from slow to fast
190-193	Stop
194-255	Counterclockwise rotation (CCW) rainbow effect, from slow to fast

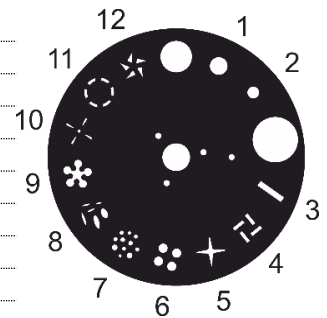

Channel 12 – Prism + rotation

0-7	Not functional
8-12	3-facet prism effect
13-130	Clockwise rotation (CW) 3-facet prism effect, from slow to fast
131-247	Counterclockwise rotation (CCW) 3-facet prism effect, from slow to fast
252-255	3-facet prism effect

Channel 13 – Focus

0-255	Continuous adjustment
-------	-----------------------

Channel 14 – Auto focus Use CH9 or 11 depending on your auto focus mode)

0-10	Not functional
11-127	Auto focus rotating gobo wheel
128-255	Auto focus static gobo wheel

Channel 15 – Zoom

0-255	Continuous adjustment, from big to small
-------	--

Channel 16 – Frost

0-4	No function
5-255	Frost effect

Channel 17 – Control / Channel Functions

0-7	No function
8-15	Blackout during Pan/Tilt movement
16-23	Blackout during color wheel movement
24-31	Blackout during gobo wheel movement
32-39	Blackout during Pan-Tilt/color wheel movement
40-47	Blackout during Pan-Tilt/gobo wheel movement
48-55	Blackout during Pan-Tilt/color wheel movement/gobo wheel movement (rotating+static)
56-87	No function
88-95	No function
96-103	Reset Pan after 5 seconds
104-111	Reset Tilt after 5 seconds
112-119	Color wheel reset after 5 seconds
120-127	Gobo wheel reset after 5 seconds
128-135	No function
136-143	Prism reset
144-151	No function
152-159	Reset all
160-255	No function

Channel 18 – Pan/Tilt built-in programs + sound-controlled programs

0-7	No Function
8-23	Built-in program 1
24-39	Built-in program 2
40-55	Built-in program 3
56-71	Built-in program 4
72-87	Built-in program 5
88-103	Built-in program 6
104-119	Built-in program 7
120-135	Built-in program 8
136-151	Sound-controlled program 1
152-167	Sound-controlled program 2
168-183	Sound-controlled program 3
184-199	Sound-controlled program 4
200-215	Sound-controlled program 5
216-231	Sound-controlled program 6
232-247	Sound-controlled program 7
248-255	Sound-controlled program 8

Maintenance

The operator has to make sure that safety-related and machine-technical installations are to be inspected by an expert after every year in the course of an acceptance test.

The operator has to make sure that safety-related and machine-technical installations are to be inspected by a skilled person once a year.

The following points have to be considered during the inspection:

- 01) All screws used for installing the device or parts of the device have to be tightly connected and must not be corroded.
- 02) There may not be any deformations on housings, fixations and installation spots.
- 03) Mechanically moving parts like axles, eyes and others may not show any traces of wearing.
- 04) The electric power supply cables must not show any damages or material fatigue.

The Phantom 280 Hybrid requires almost no maintenance. However, you should keep the unit clean. Otherwise, the fixture's light output will be significantly reduced. Disconnect the mains power supply, and then wipe the cover with a damp cloth. Do not immerse in liquid. Wipe lens clean with glass cleaner and a soft cloth. Do not use alcohol or solvents.

The front lens will require weekly cleaning, as smoke-fluid tends to build up residues, reducing the light output very quickly.

The internal lenses should be cleaned monthly, with a soft brush.

Please clean internal components once a year with a light brush and vacuum cleaner.

Keep connections clean. Disconnect electric power, and then wipe the DMX and audio connections with a damp cloth. Make sure connections are thoroughly dry before linking equipment or supplying electric power.

Replacing the Fuse

Power surges, short-circuit or inappropriate electrical power supply may cause a fuse to burn out. If the fuse burns out, the product will not function whatsoever. If this happens, follow the directions below.

- 01) Unplug the unit from electric power source.
- 02) Insert a screwdriver into the fuse holder. Turn the fuse holder counter clockwise. The fuse holder will come out.
- 03) Remove the used fuse. If brown or unclear, it is burned out.
- 04) Insert the replacement fuse into the holder where the old fuse was. Reinsert the fuse holder. Be sure to use a fuse of the same type and specification. See the product specification label for details.

Replacing a Gobo From the Rotating Gobo Wheel

- 01) Disconnect mains power supply and set the switch to OFF.
- 02) Make sure that the gobo you want to insert has the same size. For the right size, see below.

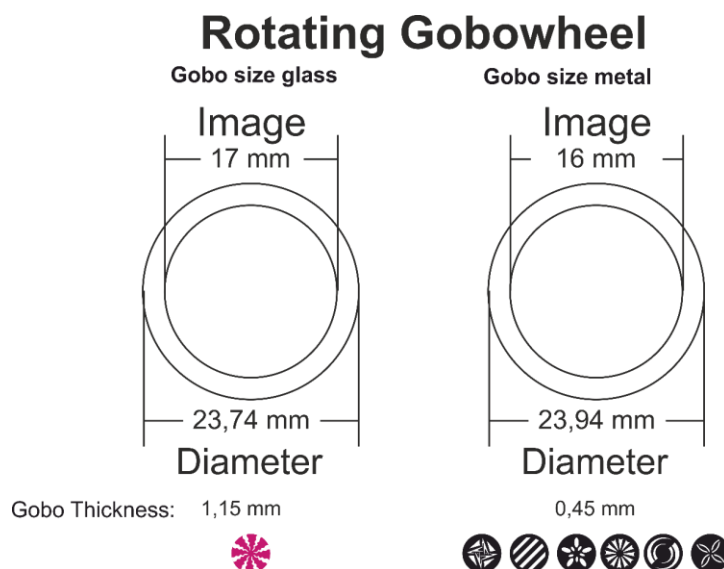

Fig. 06

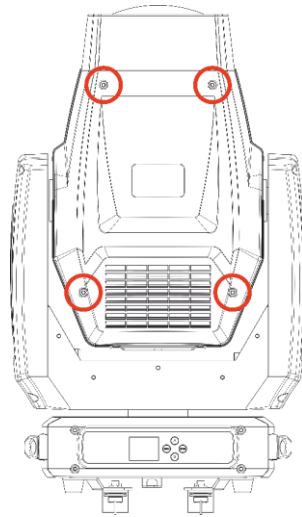

Fig. 07

- 03) Remove the lamp cover by unscrewing the 4 screws (see fig. 07).
- 04) Gently tilt the head so that the small metal housing can slide out more easily.
- 05) Turn the gobo wheel, with the gobo you want to remove, to the upside.
- 06) Gently lift up the gobo holder by 10° and then gently pull out the gobo from its position.

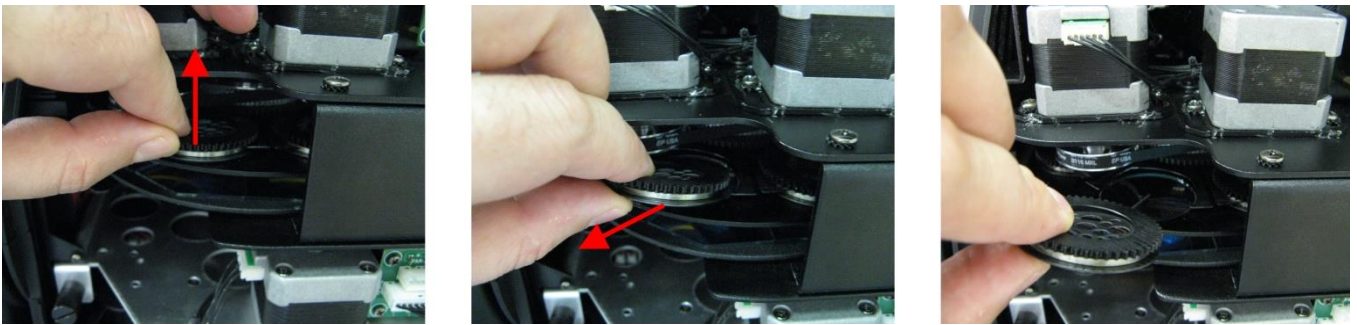

Fig. 08

- 07) Very carefully take the gobo out of the gobo holder with a pair of pliers.
- 08) Place the new gobo in the gobo holder. Carefully put the pinchcock back. You can use a pair of pliers to press the pinchcock a little bit together.
- 09) Put the gobo holder back under the pressing snap and push it back.
- 10) Replace the maintenance caps and fasten all screws.

Glass Gobo Orientation

Coated glass gobos are inserted with the coating against the rim of the holder (away from the spring). Textured gobos are inserted with the smooth side against the spring. This provides the best results when combining rotating gobos.

Coated side

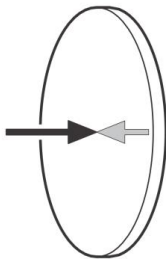

When an object is held up to the coated side there is no space between the object and its reflection. The back edge of the gobo cannot be seen when looking through the coated side.

Uncoated side

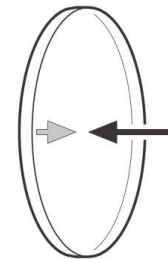

When an object is held up to the uncoated side there is a space between the object and its reflection. The back edge of the gobo can be seen when looking through the uncoated side.

Rotating Gobo Wheel + Static Gobo Wheel + Color Wheel

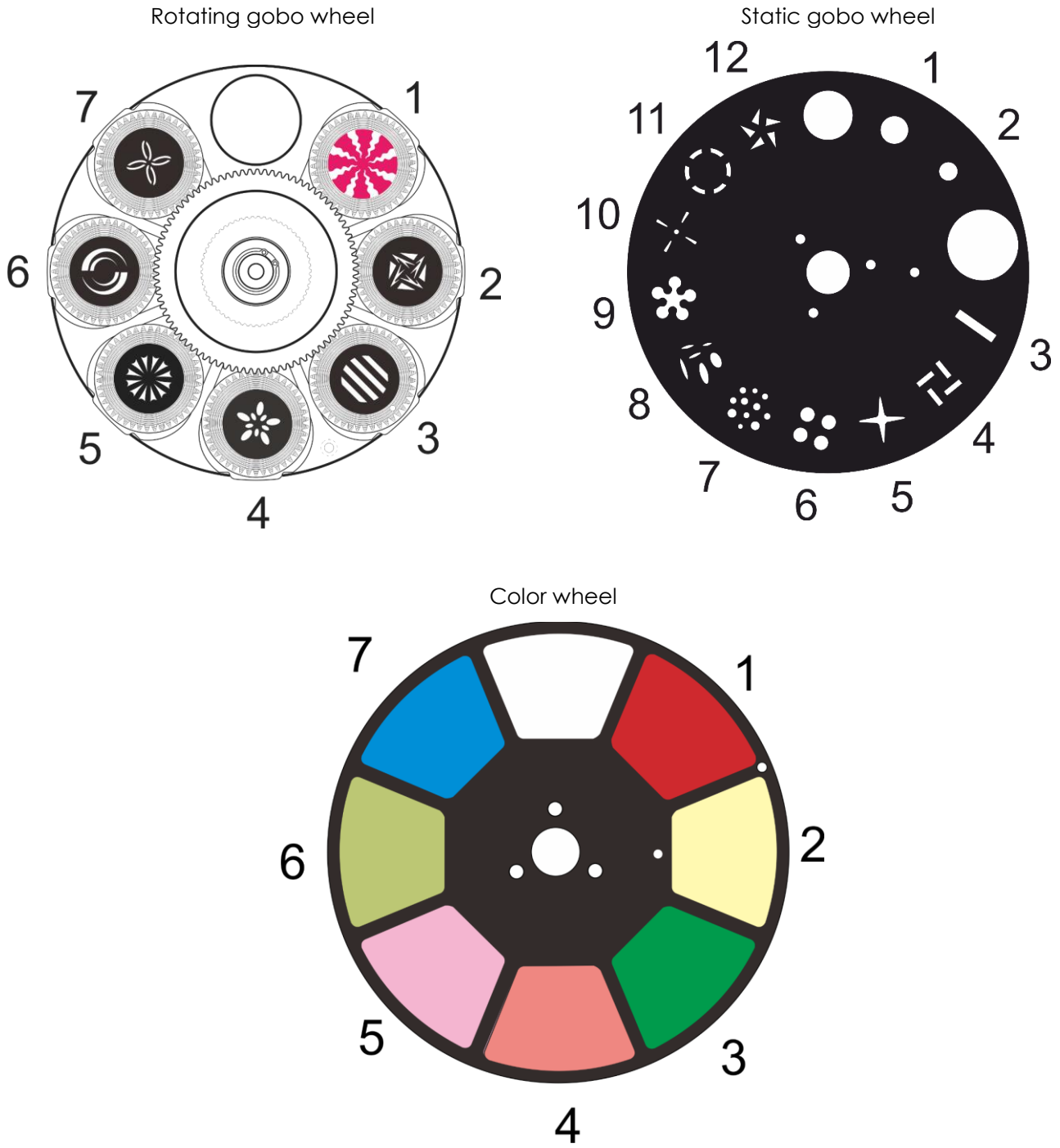

Fig. 09

Troubleshooting

This troubleshooting guide is meant to help solve simple problems.

If a problem occurs, carry out the steps below in sequence until a solution is found. Once the unit operates properly, do not carry out following steps.

No Light

If the light effect does not operate properly, refer servicing to a technician.

Suspect three potential problem areas as: the power supply, the LEDs, the fuse.

- 01) Power supply. Check if the unit is plugged into an appropriate power supply.
- 02) The LEDs. Return the Phantom to your Showtec dealer.
- 03) The fuse. Replace the fuse. See page 24 for replacing the fuse.
- 04) If all appears to be O.K., plug the unit in again.
- 05) If you are unable to determine the cause of the problem, do not open the Phantom, as this may damage the unit and the warranty will become void.
- 06) Return the device to your Showtec dealer.

No Response to DMX

Suspect the DMX cable or connectors, a controller malfunction, a light effect DMX card malfunction.

- 01) Check the DMX setting. Make sure that DMX addresses are correct.
- 02) Check the DMX cable: Unplug the unit; change the DMX cable; then reconnect to electrical power. Try your DMX control again.
- 03) Determine whether the controller or light effect is at fault. Does the controller operate properly with other DMX products? If not, take the controller in for repair. If so, take the DMX cable and the light effect to a qualified technician.

Problem	Probable cause(s)	Remedy
One or more fixtures do not function at all.	No power to the fixture.	<ul style="list-style-type: none"> • Check if power is switched on and cables are plugged in.
	Primary fuse blown.	<ul style="list-style-type: none"> • Replace fuse.
Fixtures reset correctly, but all respond erratically or not at all to the controller.	The controller is not connected.	<ul style="list-style-type: none"> • Connect controller.
	3-pin XLR Out of the controller does not match XLR In of the first fixture on the link (i.e. signal is reversed).	<ul style="list-style-type: none"> • Install a phase reversing cable between the controller and the first fixture on the link.
Fixtures reset correctly, but some respond erratically or not at all to the controller.	Poor data quality.	<ul style="list-style-type: none"> • Check data quality. If much lower than 100 percent, the problem may be a bad data link connection, poor quality or broken cables, missing termination plug, or a defective fixture disturbing the link.
	Bad data link connection.	<ul style="list-style-type: none"> • Inspect connections and cables. Correct poor connections. Repair or replace damaged cables.
	Data link not terminated with 120 Ohm termination plug.	<ul style="list-style-type: none"> • Insert termination plug in output jack of the last fixture on the link.
	Incorrect addressing of the fixtures.	<ul style="list-style-type: none"> • Check address setting.
	One of the fixtures is defective and disturbs data transmission on the link.	<ul style="list-style-type: none"> • Bypass one fixture at a time until normal operation is regained: unplug both connectors and connect them directly together. • Have the defective fixture serviced by a qualified technician.
No light or LEDs cut out intermittently	3-pin XLR Out on the fixtures does not match (pins 2 and 3 reversed).	<ul style="list-style-type: none"> • Install a phase-reversing cable between the fixtures or swap pin 2 and 3 in the fixture, that behaves erratically.
	Fixture is too hot.	<ul style="list-style-type: none"> • Allow fixture to cool. • Clean fan. • Make sure air vents are not blocked. • Turn up the air conditioning.
	LEDs damaged.	<ul style="list-style-type: none"> • Disconnect fixture and return to your dealer.
	The power supply settings do not match local AC voltage and frequency.	<ul style="list-style-type: none"> • Disconnect fixture. Check settings and correct if necessary.

Product Specifications

Model:	Showtec Phantom 280 Hybrid
Input voltage:	100–240 V AC, 50/60 Hz (auto ranging)
Power consumption:	395 W
DMX linking:	30pcs
Fuse:	F7AL/250V
Dimensions:	367 x 211 x 610 mm (LxWxH)
Weight:	19,14 kg
Operating and Programming:	
Signal pin OUT:	Pin 1 (earth), pin 2 (-), pin 3 (+)
DMX Mode:	13, 18 channels
Signal input:	3-pin XLR IN
Signal output:	3-pin XLR OUT
Electro-mechanical effects:	
Light source:	280W White LED
Light output:	83708 lux (3°) @ 5 m
Beam angle:	3–25,4° (motorized)
Dimmer:	0–100 % Mechanical
Strobe:	0–20 Hz
Focus:	Motorized
Zoom:	Motorized
Housing:	Metal & flame-retardant plastic
DMX control:	via standard DMX controller
Prism Effect	3-facet circular rotating prism
Onboard:	Full colour display for easy setup
User-selectable Pan range:	540°/360°/180°
User-selectable Tilt range:	270°/180°/90°
Pan/Tilt resolution:	16 bit
Control:	Auto, Manual, Sound-controlled, Master/Slave, DMX-512
Connections:	3-pin XLR IN/OUT, Pro power connector IN/OUT
Color:	Black
IP rating:	IP20
Cooling:	Cooling fan
Pan / Tilt movement blackout, User-selectable Pan / Tilt ranges, 540°/360°/180° Reverse Pan / Tilt movement	
Built-in automatic programs + built-in sound-activated programs	
Pan: 0–540°, Tilt: 0–270°	
Static gobo wheel 1: 12 gobos + open	
Rotating gobo wheel: 1 glass gobo + 6 metal gobos open	
Gobo size: Glass gobo: 23,74 mm (gobo size); 17 mm (image diameter); 1,15 mm (gobo thickness) Metal gobo: 23,94 mm (gobo size); 16 mm (image diameter); 0,45 mm (gobo thickness)	
Gobo function: Gobo-flow effect, Gobo shake	
Colours: 7 dichroic colors + white	
Colour effect: Split-colours, Rainbow-flow effect	
Max. ambient temperature t_a :	40°C
Max. housing temperature t_B :	70°C
Minimum distance:	
Minimum distance from flammable surfaces:	0,8 m
Minimum distance to lighted object:	3 m

Design and product specifications are subject to change without prior notice.



Website: www.Showtec.info
Email: service@highlite.com

Dimensions

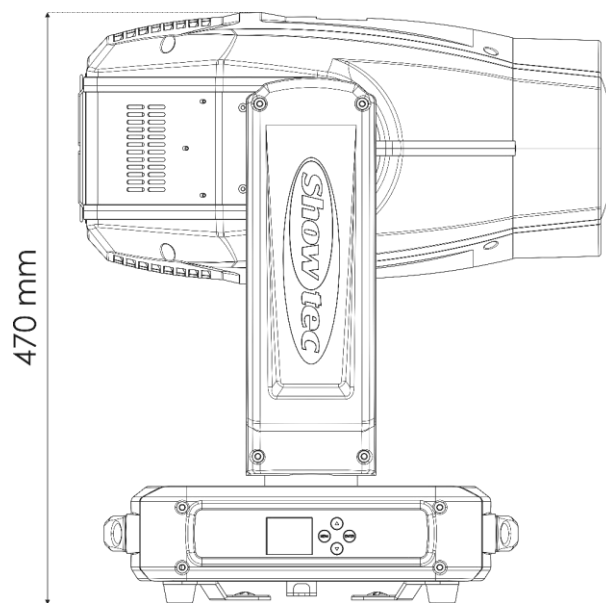
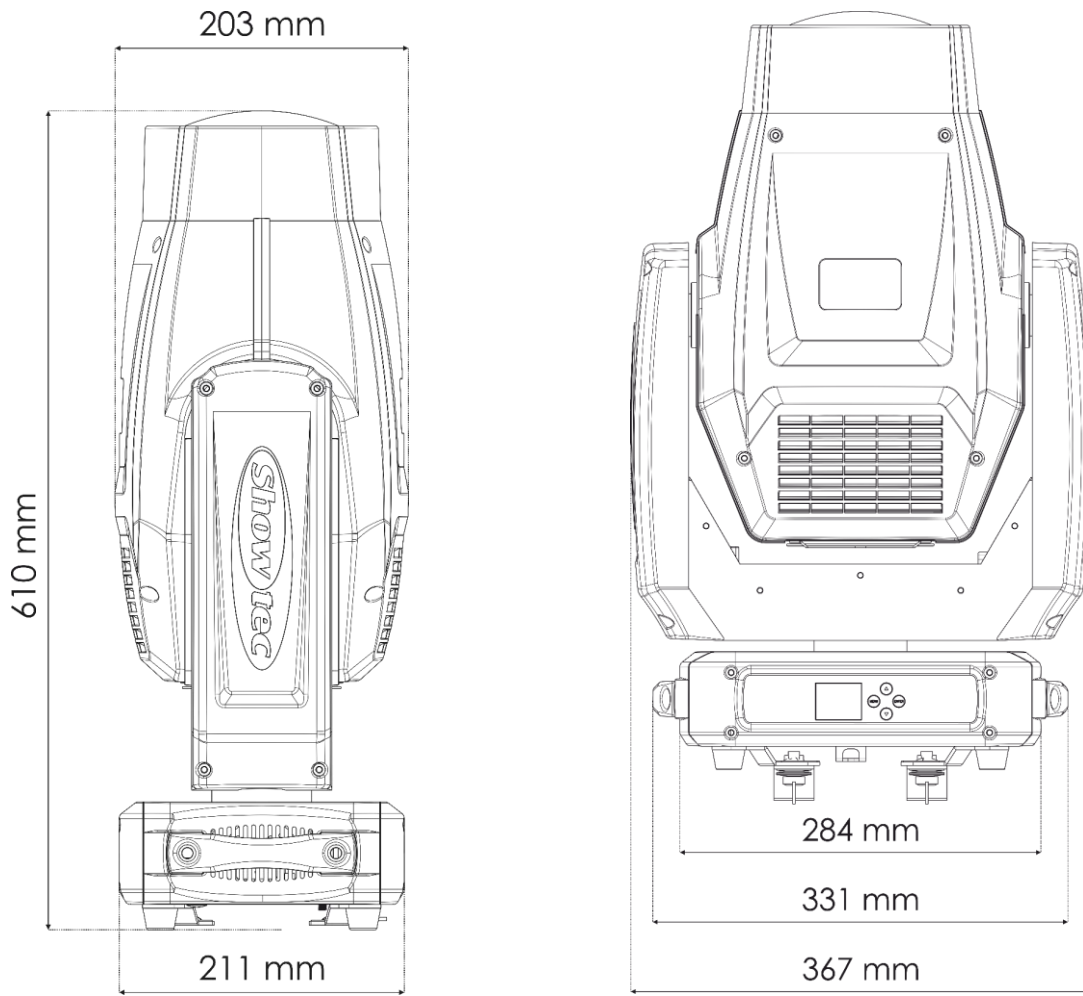



©2019 Showtec