

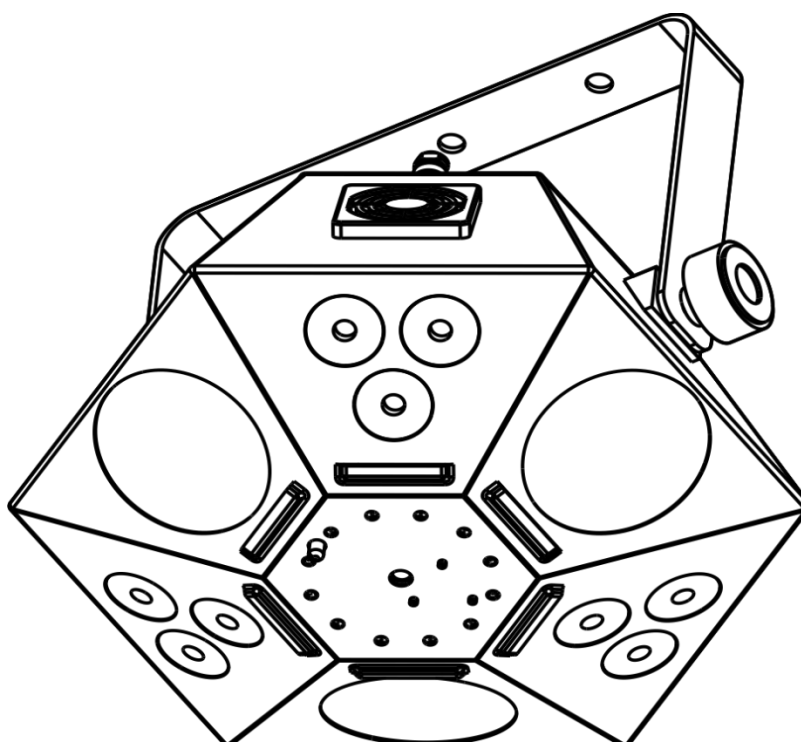

MANUAL



ENGLISH

Magician LED

V2

Ordercode: 43161

Table of contents

Warning	2
Safety Instructions	2
Operating Determinations	5
Laser safety for a Class 2M Laser Product	5
Rigging	7
Connection with the mains.....	7
Return Procedure	8
Claims.....	8
Description of the device	9
Optional accessories.....	9
Overview	10
Backside	11
Installation	11
Set Up and Operation	11
Control Modes	13
One Magician (Auto Program and Static Color Mode)	13
One Magician (Sound-controlled)	13
Multiple Magicians (Master/Slave control)	13
Multiple Magicians (DMX Control)	14
Fixture Linking	15
Data Cabling	15
Control Panel	16
Control Mode	16
DMX Addressing	16
Menu Overview	17
Main Menu Options	17
1. Auto Run Programs.....	18
2. Sound-controlled Mode	18
3. Static Control Mode	19
4. Slave mode.....	19
5. DMX Channels / DMX Address.....	19
6. System Settings.....	20
Remote Control.....	21
DMX Channels	22
3 channels	22
5 channels	24
11 channels.....	25
28 channels.....	26
Maintenance	32
Replacing the Fuse	32
Troubleshooting	33
No Light	33
No Response to DMX.....	33
Product Specifications	35
Dimensions	36
Notes	37

Warning



**For your own safety, please read this user manual carefully
before your initial start-up!**



Unpacking Instructions

Immediately upon receiving this product, carefully unpack the carton and check the contents to ensure that all parts are present, and have been received in good condition. Notify the dealer immediately and retain packing material for inspection if any parts appear damaged from shipping or the carton itself shows signs of mishandling. Save the carton and all packing materials. In the event that a fixture must be returned to the factory, it is important that the fixture be returned in the original factory box and packing.

Your shipment includes:

- Showtec Magician LED
- IEC Power cable (1,5 m)
- 2 keys for the interlock
- Remote control plug
- IR Remote control
- User manual

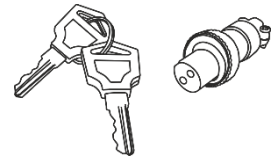
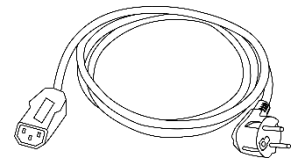
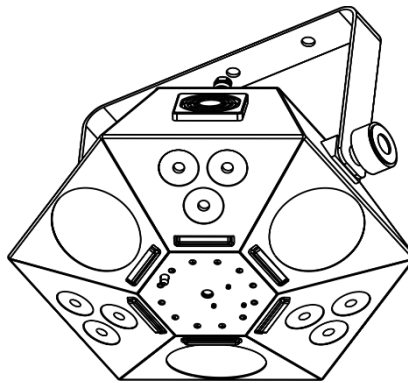

LED Expected Lifespan

LEDs gradually decline in brightness over time. HEAT is the dominant factor that leads to the acceleration of this decline. Packaged in clusters, LEDs exhibit higher operating temperatures than in ideal or singular optimum conditions. For this reason, when all color LEDs are used at their fullest intensity, life of the LEDs is significantly reduced. If improving the lifespan is of higher priority, place care in providing for lower operational temperatures. This may include climatic-environmental and the reduction of overall projection intensity.



CAUTION!

**Keep this device away from rain and moisture!
Unplug mains lead before opening the housing!**



Safety Instructions

Every person involved with the installation, operation and maintenance of this device has to:

- be qualified
- follow the instructions of this manual



**CAUTION! Be careful with your operations.
With a dangerous voltage you can suffer
a dangerous electric shock when touching the wires!**



Before the initial start-up, please make sure that there is no damage caused by transportation. Should there be any, consult your dealer and do not use the device.

To maintain perfect condition and to ensure a safe operation, it is absolutely necessary for the user to follow the safety instructions and warning notes contained in this manual.

Please consider that damages caused by manual modifications to the device are not subject to warranty.

This device contains no user-serviceable parts. Refer servicing to qualified technicians only.

IMPORTANT:

The manufacturer will not accept liability for any resulting damages caused by the non-observance of this manual or any unauthorized modification to the device.

- Never let the power cord come into contact with other cables! Handle the power cord and all connections with the mains with particular caution!
- Never remove warning or informative labels from the unit.
- Never use anything to cover the ground contact.
- Never lift the fixture holding it by the projector-head, as the mechanics may be damaged. Always hold the fixture by the transport handles.
- Never place any material over the lens.
- Never look directly into the light source.
- Never leave any cables lying around.
- Never aim the laser beam at people or animals!
- Never use the device during thunderstorms, unplug the device immediately.
- Never point a laser at aircraft, this is a federal offense.
- Never point unterminated laser beams into the sky.
- Never open the laser housing. The high laser power levels inside of the protective housing can start fires, burn skin and will cause instant eye injury.
- Do not insert objects into air vents.
- Do not connect this device to a dimmerpack.
- Do not open the device and do not modify the device.
- Do not point lasers at highly reflective surfaces such as windows, mirrors and shiny metal. Even laser reflections can be hazardous.
- Do not expose the output optic (aperture) to cleaning chemicals.
- Do not use laser if the laser appears to be emitting only one or two beams.
- Do not use laser if housing is damaged or open, or if optics appear damaged in any way.
- Do not operate laser without first reading and understanding all safety and technical data in this manual. Never look into the laser aperture or laser beams.
- Do not switch the device on and off in short intervals, as this will reduce the device's life.
- Do not touch the device's housing bare-handed during its operation (housing becomes very hot). Allow the fixture to cool for at least 5 minutes before handling.
- Do not shake the device. Avoid brute force when installing or operating the device.
- After set up and prior to public use, test laser to ensure proper function. Do not use the laser if any defect is detected. Do not use, if the laser emits only one or two laser beams rather than dozens/hundreds, as this could indicate damage to the diffraction grating optic, and could allow emission of higher laser levels.
- Only use the device indoors, avoid contact with water or other liquids.
- Only operate the fixture after having checked if the housing is firmly closed and all screws are tightly fastened.
- Only operate the device after having familiarized with its functions.
- Avoid flames and do not put close to flammable liquids or gases.

- Always check the regulations when using a class 2M laser product.
- Always check and position the laser before anybody enters the room, when the laser is facing an area with people.
- Always keep the case closed while operating.
- Always allow a free air space of at least 50 cm around the unit for ventilation.
- Always disconnect power from the mains, when device is not used or before cleaning! Only handle the power cord holding it by the plug. Never pull out the plug by tugging the power cord.
- Make sure that the device is not exposed to extreme heat, moisture or dust.
- Make sure that the available voltage is not higher than stated on the rear panel.
- Make sure that the power cord is never crimped or damaged. Check the device and the power cord from time to time.
- If the external cable is damaged, it has to be replaced by a qualified technician.
- If the lens is obviously damaged, it has to be replaced. So that its functions are not impaired, due to cracks or deep scratches.
- If device was dropped or struck, disconnect mains power supply immediately. Have a qualified engineer inspect for safety before operating.
- If the device has been exposed to drastic temperature fluctuation (e.g. after transportation), do not switch it on immediately. The arising condensation water might damage your device. Leave the device switched off until it has reached room temperature.
- If your Showtec device fails to work properly, discontinue the use immediately. Pack the unit securely (preferably in the original packing material), and return it to your Showtec dealer for service.
- For adult use only. The fixture must be installed beyond the reach of children. Never leave the unit running unattended.
- Never attempt to bypass the thermostatic switch or fuses.
- For replacement use fuses of same type and rating only.
- The operation of a class 2M laser show is only allowed if the show is controlled by a skilled and well-trained operator familiar with the data included in this manual.
- The user is responsible for correct positioning and operating of the Magician LED. The manufacturer will not accept liability for damages caused by the misuse or incorrect installation of this device.
- This device falls under protection class I. Therefore it is essential to connect the yellow/green conductor to earth.
- The laser will only work between 10-35°C.
- After 3 hours working, you must shut off the laser and let the laser diode cool off for 30 minutes, otherwise the laser could be damaged and the warranty becomes void.
- Repairs, servicing and electric connection must be carried out by a qualified technician.
- WARRANTY: Till one year after date of purchase.

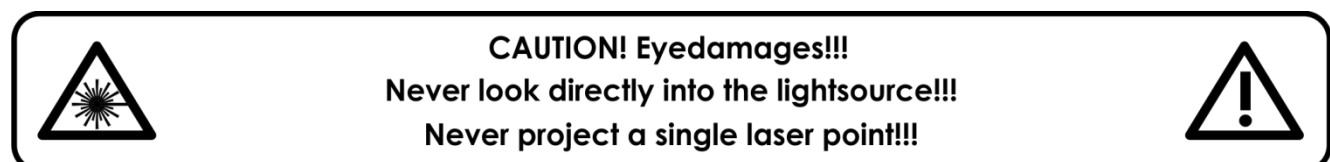
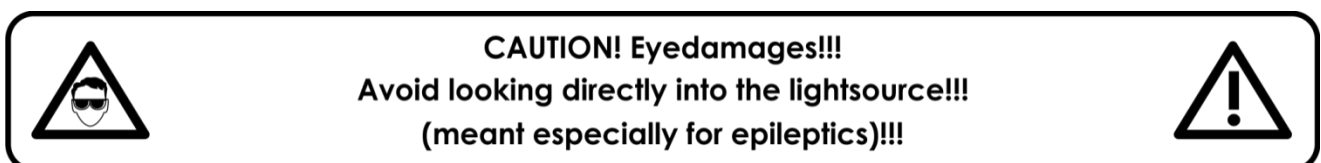
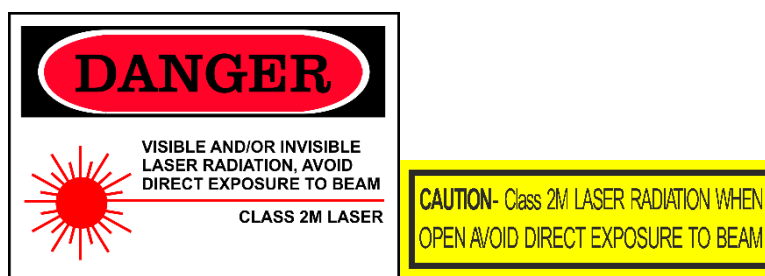

Operating Determinations

- This device is not designed for permanent operation. Consistent operation breaks will ensure that the device will serve you for a long time without defects.
- The minimum distance between light output and the illuminated surface must be bigger than 1 meter.
- The maximum ambient temperature $t_a = 40^\circ\text{C}$ must never be exceeded.
- The relative humidity must not exceed 50 % with an ambient temperature of 40°C .
- If this device is operated in any other way than the one described in this manual, the product may suffer damages and the warranty becomes void.
- Any other operation may lead to dangers like short-circuit, burns, electric shock, crash, etc.

You endanger your own safety and the safety of others!

Laser safety for a Class 2M Laser Product

Laser Light is different from any other light source with which you may be familiar with. This laser is less dangerous than a higher class laser such as an 3 or 4. The light from this product is safe for unintentional (<1/4 sec) unaided eye exposure. However this device is potentially hazardous if viewed with certain optical instruments such as binoculars or eye loupe.

Laser light is thousands of times more concentrated than light from any other kind of light source. This concentration of light power can cause instant eye injuries, primarily by burning the retina (the light sensitive portion at the back of the eye). Even if you cannot feel "heat" from a laser beam, it can still potentially injure or blind you or your audience.

Even very small amounts of laser light are potentially hazardous even at long distances. Laser eye injuries can happen quicker than you can blink.

It is incorrect to think that because these laser products split the laser into hundreds of beams or the laser beam is scanned out in high speed, that an individual laser beam is safe for eye exposure. This laser product uses dozens of milliwatts of laser power (Class 2M levels internally). Many of the individual beams are potentially hazardous to the eyes.

It is also incorrect to assume that because the laser light is moving, it is safe. This is not true. Nor, do the laser beams always move. Since eye injuries can occur instantly, it is critical to prevent the possibility of any direct eye exposure. According to the laser safety regulation, it is not legal to aim Class 2M lasers in areas which people can get exposed. This is true even if it is aimed below people's faces, such as on a dance floor.

CAUTION! Only Laser Safety Officers who are officially certified by a regulatory body or authorized training organization are allowed to use class 2M lasers in public. The Laser Safety Officer is responsible for all aspects when using this laser, including following all locally applicable safety laws and regulations. The manufacturer will not accept liability for damages caused by the misuse or incorrect installation of this laser.



CAUTION: AVOID EXPOSURE TO BEAM: Avoid direct eye contact with laser light. Never intentionally expose your eyes or others to direct laser radiation.

Compliance Statement

Your Galactic Laser has been designed to comply with FDA and IEC Standards for its classification. The Galactic is a Class 2M laser product.

Laser Safety and Compliance Information

The Galactic is manufactured to comply with the IEC 60825-1 and in accordance with U.S. Food and Drug Administration (FDA) Standards Listed under FDA Document 21 CFR 1040 and subsequent laser notices.

Product Classification and Manufacturing Label Identification

Laser Classification	Class 2M
Cooling	Cooling fans and TE Cooling
Laser medium	wavelength 650 nm / Red (Laser Diode GaAlAs) ; Output >100mW wavelength 532 nm / Green (DPSS Nd: YVO4); Output >30mW
Output	130mW
Beam Diameter	<5mm at aperture
Pulse Data All pulses	< 4Hz (>0.25sec)
Divergence (each beam)	<2 mrad
Divergence (total light)	<160 degrees

The legal requirements for using laser entertainment products vary from country to country. The user is responsible for the legal requirements at the location/country of use.

Further guidelines and safety programs for safe use of lasers can be found in the ANSI Z136.1 Standard "For Safe Use of Lasers", available from www.lia.org/. Many local governments, corporations, agencies, military and others, require all lasers to be used under the guidelines of ANSI Z136.1. Laser Display guidance can be obtained via the International Laser Display Association, www.ilda.com/index.htm.

CAUTION: The use of corrective eye wear or optics for viewing at distances such as telescopes or binoculars within a distance of 100mm may pose an eye hazard.



This laser product is a Class 2M laser and has an interlocked housing.



There are no user serviceable parts inside. Tampering or removing warranty seals will void your products limited warranty.



Combo label with the Product Model Number, Serial Number, Date of Manufacturing, Laser Light Warning Label, Warranty Void Label and Interlocked Housing Label

Proper Usage Safety and Compliance Information

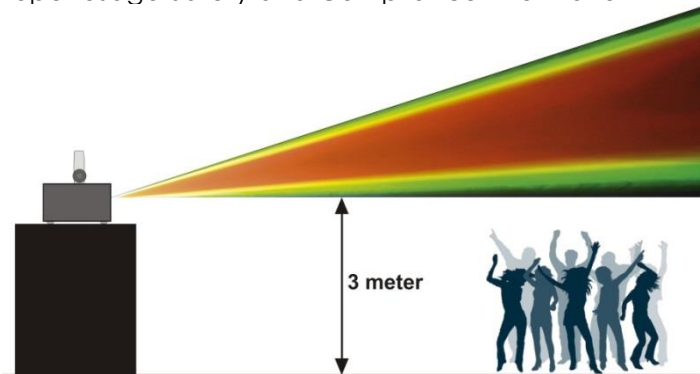

According to FDA Regulations you should operate this product as stated on the left.

Rigging

Please follow the European and national guidelines concerning rigging, trussing and all other safety issues.

Do not attempt the installation yourself !

Always let the installation be carried out by an authorized dealer !

Procedure:

- If the Magician is lowered from the ceiling or high joists, professional trussing systems have to be used.
- Use a clamp to mount the Magician, with the mounting bracket, to the trussing system.
- The Magician must never be fixed swinging freely in the room.
- The installation must always be secured with a safety attachment, e.g. an appropriate safety net or safety cable.
- When rigging, derigging or servicing the Magician, always make sure, that the area below the installation site is secured and that there are not any unauthorized people around.

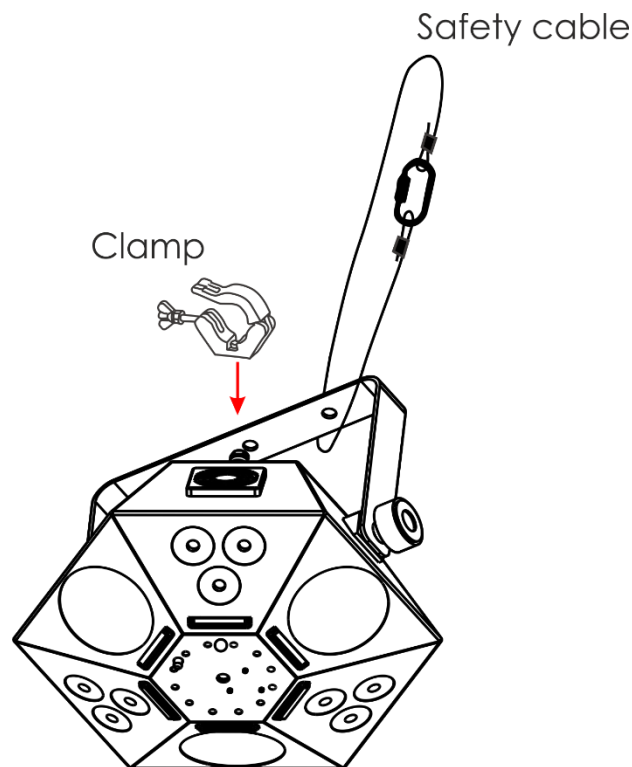

The Magician LED can be placed on a flat stage floor or mounted to any kind of truss with a clamp.

Improper installation can cause serious injuries and/or damage of property!

Connection with the mains

Connect the device to the mains with the power-plug.

Always check if the right color cable is connected to the right place.

International	EU Cable	UK Cable	US Cable	Pin
L	BROWN	RED	YELLOW/COPPER	PHASE
N	BLUE	BLACK	SILVER	NEUTRAL
	YELLOW/GREEN	GREEN	GREEN	PROTECTIVE GROUND

Make sure that the device is always properly connected to the earth!

Improper installation can cause serious injuries and/or damage of property!



Return Procedure

Returned merchandise must be sent prepaid and in the original packing, call tags will not be issued. Package must be clearly labeled with a Return Authorization Number (RMA number). Products returned without an RMA number will be refused. Highlite will not accept the returned goods or any responsibility. Call Highlite 0031-455667723 or mail aftersales@highlite.nl and request an RMA prior to shipping the fixture. Be prepared to provide the model number, serial number and a brief description of the cause of the return. Be sure to properly pack fixture as any shipping damage resulting from inadequate packaging is the customer's responsibility. Highlite reserves the right to use its own discretion to repair or replace product(s). As a suggestion, proper UPS packing or double-boxing is always a safe method to use.

Note: If you are given an RMA number, please include the following information on a piece of paper inside the box:

- 01) Your name.
- 02) Your address.
- 03) Your phone number.
- 04) A brief description of the symptoms.

Claims

The client has the obligation to check the delivered goods immediately upon delivery for any shortcomings and/or visible defects, or perform this check after our announcement that the goods are at their disposal. Damage incurred in shipping is the responsibility of the shipper; therefore the damage must be reported to the carrier upon receipt of merchandise.

It is the customer's responsibility to notify and submit claims with the shipper in the event that the fixture is damaged due to shipping. Transportation damage has to be reported to us within one day after receipt of the delivery.

Any return shipment has to be made post-paid at all times. Return shipments must be accompanied with a letter defining the reason for return shipment. Non-prepaid return shipments will be refused, unless agreed otherwise in writing.

Complaints against us must be made known in writing or by fax within 10 working days after receipt of the invoice. After this period, complaints will not be handled anymore.

Complaints will only be considered if the client has so far complied with all parts of the agreement, regardless of the agreement of which the obligation is resulting.

Description of the device

Features

The Magician LED is a multifunctional light effect with high output and great effects. It combines laser effects, strobe effects and LED effects in one device.

- Multifunctional device
- IR remote and DMX control
- RGB-UV Wash LEDs
- RGBA Beam LEDs
- Input voltage: 100-240V AC, 50/60Hz
- Power consumption: 90W
- DMX channels: 3, 5, 11 or 28 channels
- 4-digit LED display for easy setup
- Control modes: Auto, Sound-controlled, Static color, Master/Slave, DMX
- Control protocol: DMX-512
- Protection rate: IP-20
- Housing: Die-cast black aluminum
- Cooling: Fans/Convection
- Connections: IEC connectors (IN/OUT), 3-pin XLR (IN/OUT)
- Fuse: T1.6L/250V
- Dimensions: 350 x 320 x 185 mm (LxWxH) (incl. bracket)
- Weight: 3,1 kg

Wash LED effect

- Light source: 9 x 4W RGB-UV LEDs

Beam LED effect

- Light source: 3 x Beam LEDs (8 x 0,75W Red, 6 x 0,75W Green, 6 x 0,75W Blue, 8 x 0,75W Amber)

Laser effect

- Laser Color: Red, Green
- Laser Power: 130mW (100mW 650nm Red, 30mW 532nm Green)
- Laser Class: 2M
- Safety Features: Key switch, Interlock, Safety eye
- Laser Safety: EN/IEC 60825-1 Ed 2, 2007-03

Strobe effect

- Light source: 12 x 0,5W White 5730 LEDs

Note: Knowledge of DMX is required to fully utilize this unit.

Optional accessories

[51316](#) Remote Interlock

Overview

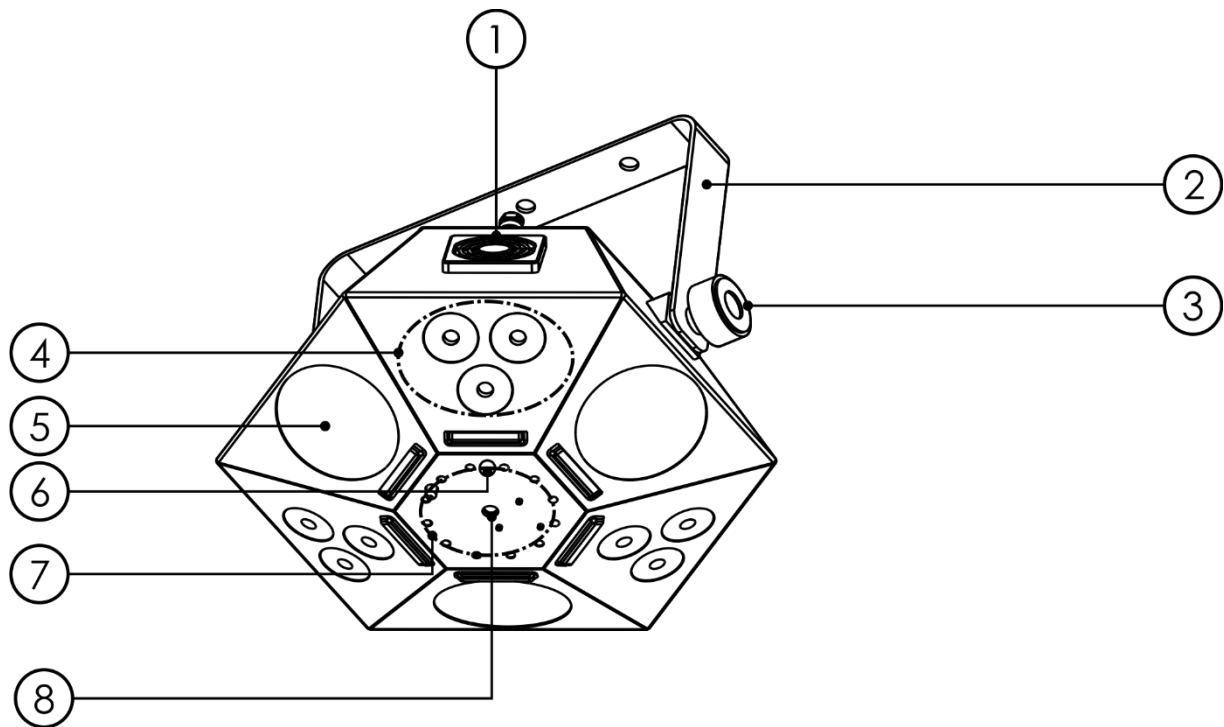

Fig. 01

- 01) Fan
- 02) Mounting bracket
- 03) Adjustment screw
- 04) 9 x 4W RGB-UV Wash LEDs
- 05) 3 x Beam LEDs (8 x 0,75W Red, 6 x 0,75W Green, 6 x 0,75W Blue, 8 x 0,75W Amber)
- 06) IR sensor
- 07) 12 x 0,5W White 5730 LEDs
- 08) Laser lens

Backside

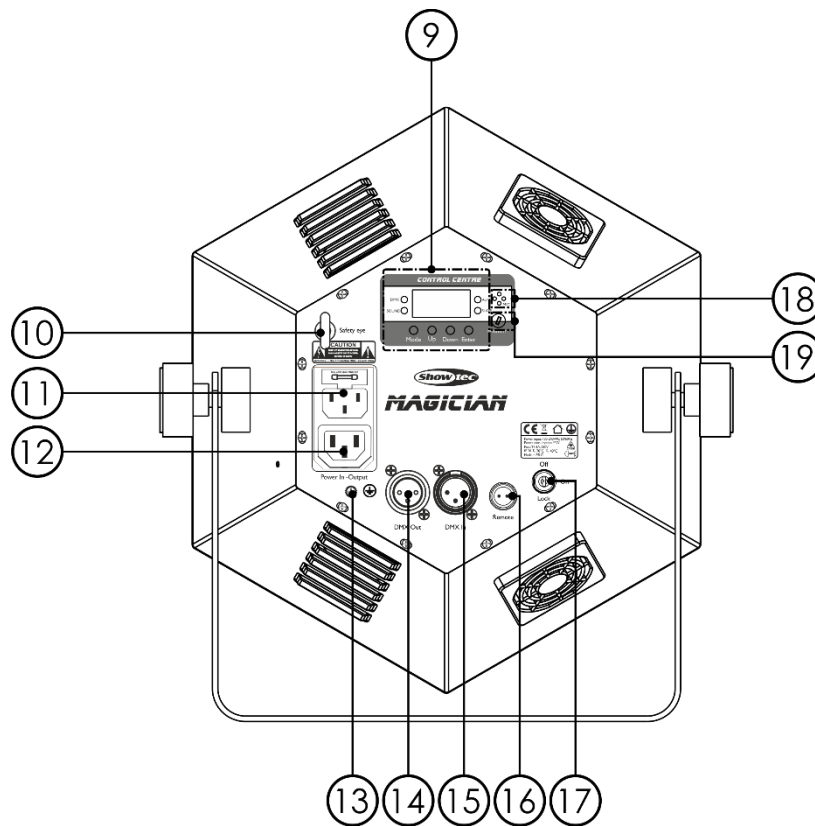

Fig. 02

- 09) LED display + menu buttons + Function LED indicators
- 10) Safety eye
- 11) IEC Power connector IN + Fuse T1.6L/250V
- 12) IEC Power connector OUT
- 13) Ground/earth connection
- 14) 3-pin DMX signal connector OUT
- 15) 3-pin DMX signal connector IN
- 16) Remote control plug
- 17) Interlock
- 18) Built-in microphone
- 19) Sound sensitivity control

Installation

Remove all packing materials from the Magician LED. Check if all foam and plastic padding is removed. Connect all cables.

Do not supply power before the whole system is set up and connected properly.

Always disconnect from electric mains power supply before cleaning or servicing.

Damages caused by non-observance are not subject to warranty.

Set Up and Operation

Follow the directions below, as they pertain to your preferred operation mode.

Before plugging the unit in, always make sure that the power supply matches the product specification voltage. Do not attempt to operate a 120V specification product on 230V power, or vice versa.

Connect the device to the main power supply. The device can be sound-controlled as it is equipped with a built-in microphone.

The Interlock plug/remote plug and safety keys are included in the box.
The interlock is the "included-in-the-box" successor for the optional remote interlock ([51316](#)).

⚠ They should be kept with the Magician !!! ⚠

The following safety precautions should be followed:

- The remote control plug should be placed on the backside **(16)** of your Magician.
- The keys should be put into the lock **(17)** of your Magician.

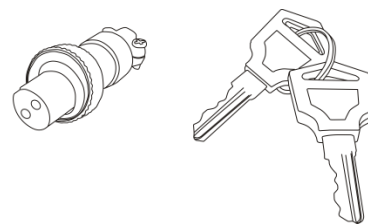

⚠ Warning ⚠

If the plug is not connected, your laser will not function.
If the key is not set to ON, your laser will not function.

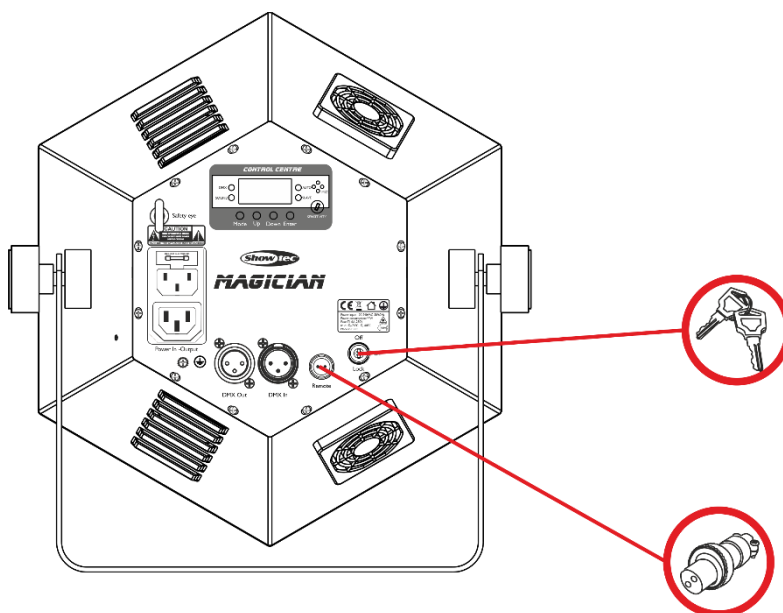

Fig. 03

Exclusion of liability

Be aware that in some countries, there are additional regulations, regarding the use of laser devices. Therefore, we strongly advise you to verify your national laws with your authorities: We do not take any responsibility for eventual discrepancies, changes or adaptations regarding lawful use of laser devices.

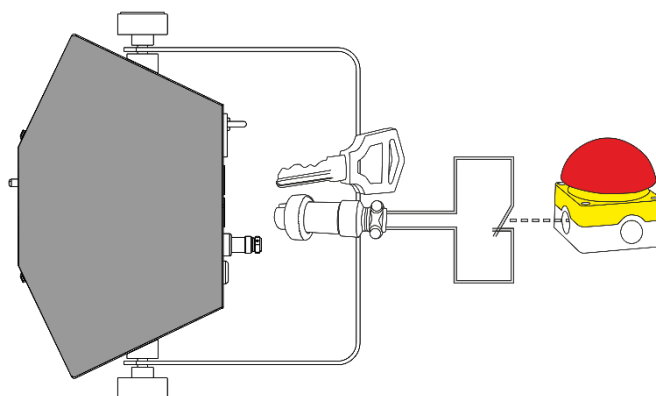

Fig. 04

Control Modes

There are 5 modes:

- Auto Program
- Static Color (manual)
- Sound-controlled
- Master/slave
- DMX-512 (3CH, 5CH, 11CH or 28CH)

One Magician (Auto Program and Static Color Mode)

- 01) Fasten the effect light to a firm trussing. Leave at least 0,5 meter on all sides for air circulation.
- 02) Always use a safety cable (ordercode 70140 / 70141).
- 03) Plug the end of the electric mains power cord into a proper electric power supply socket.
- 04) When the Magician is not connected with a DMX cable, it functions as a stand-alone device.
Please see pages 18 and 19 for more information about Auto Program and Static Color Mode.

One Magician (Sound-controlled)

- 01) Fasten the effect light to a firm trussing. Leave at least 0,5 meter on all sides for air circulation.
- 02) Always use a safety cable (ordercode 70140 / 70141).
- 03) Plug the end of the electric mains power cord into a proper electric power supply socket.
- 04) Turn on the music. If the device is set to sound-control, then the Magician will react to the beat of the music. Please see page 18 for more information about the sound-control options.

Multiple Magicians (Master/Slave control)

- 01) Fasten the effect light onto firm trussing. Leave at least 0,5 meter on all sides for air circulation.
- 02) Always use a safety cable (ordercode 70140 / 70141).
- 03) Use a 3-p XLR cable to connect the Magician and other devices.

The pins:



1. Earth
2. Signal (-)
3. Signal (+)

- 04) Link the units as shown in Fig. 05, connect a DMX signal cable from the first unit's DMX "out" socket to the second unit's "in" socket. Repeat this process to link the second, third and fourth units. You can use the same functions on the master device as described on pages 18 and 19 (Auto, Static color). This means you can set your desired operation mode on the master device and all slave devices will react the same as the master device.

Multiple Magicians (Master/Slave control)

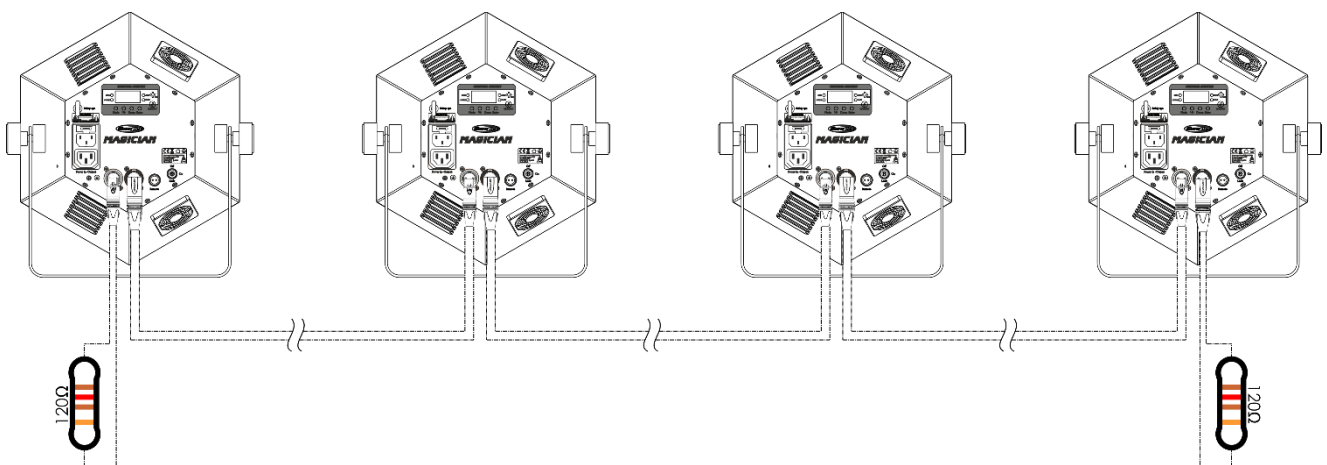
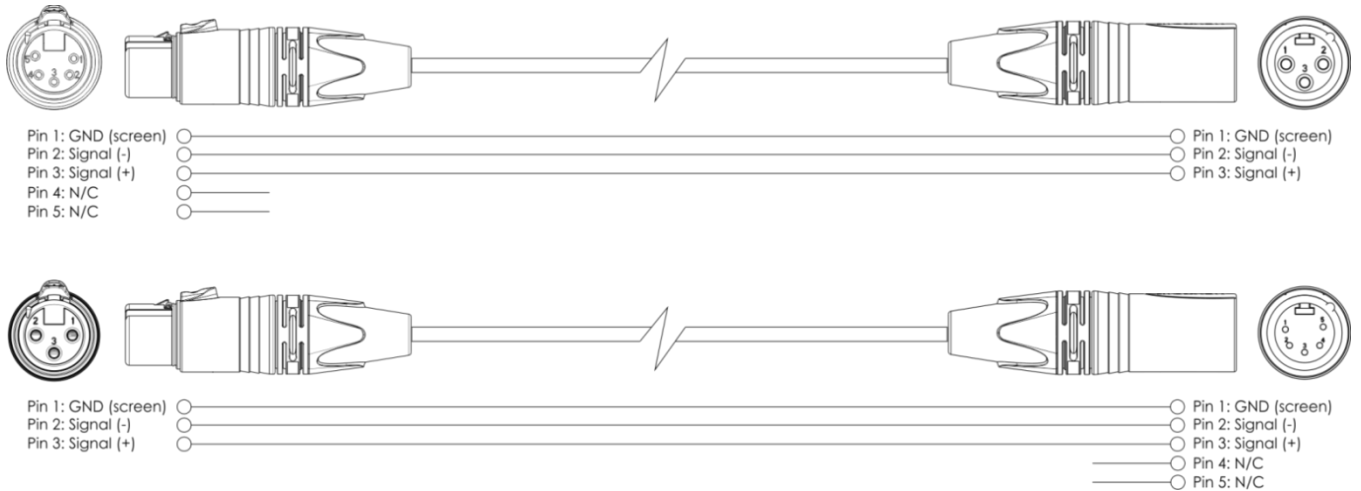

Fig. 05

Multiple Magicians (DMX Control)

- 01) Fasten the effect light to a firm trussing. Leave at least 0,5 meter on all sides for air circulation.
- 02) Always use a safety cable (ordercode 70140 / 70141).
- 03) Use a 3-pin XLR cable to connect the Magicians and other devices.



- 04) Link the units as shown in Fig. 06. Connect the first unit's DMX "out" socket with the second unit's "in" socket, using a DMX-signal cable. Repeat this process to link the second, third and fourth units.
- 05) Supply electric power: Plug electric mains power cords into each unit's IEC socket, then plug the other end of the mains power cord into proper electric power supply sockets, starting with the first unit. Do not supply power before the whole system is set up and connected properly.

Multiple Magicians DMX Set Up

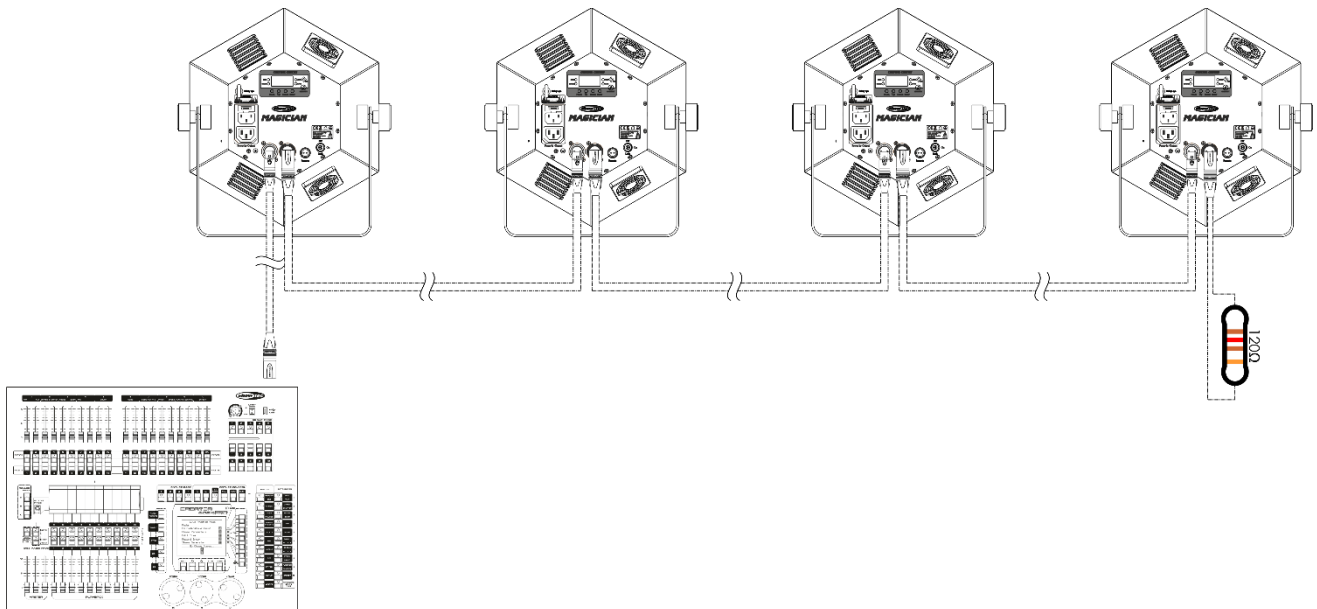

Fig. 06

Note: Link all cables before connecting electric power

Fixture Linking

You will need a serial data link to run light shows of one or more fixtures using a DMX-512 controller or to run synchronized shows of two or more fixtures set to a master/slave operating mode. The combined number of channels required by all the fixtures on a serial data link determines the number of fixtures the data link can support.

- Important:** Fixtures on a serial data link must be daisy-chained in a single line. To comply with the EIA-485 standard, no more than 30 devices should be connected on one data link. Connecting more than 30 fixtures on one serial data link without the use of a DMX optically isolated splitter may result in deterioration of the digital DMX signal.
- Maximum recommended DMX data link distance: 100 meters
 - Maximum recommended number of fixtures on a DMX data link: 30 fixtures
 - Maximum recommended number of fixtures on a power link @ 110V: 10 fixtures
 - Maximum recommended number of fixtures on a power link @ 240V: 20 fixtures



Data Cabling

To link fixtures together, you must obtain data cables. You can purchase DAP Audio certified DMX cables directly from a dealer/distributor or construct your own cable. If you choose to create your own cable, please use data-grade cables that can carry a high quality signal and are less prone to electromagnetic interference.

DAP Audio DMX Data Cables

- DAP Audio Basic microphone cable for allround use. bal. XLR/M 3-pin > XLR/F 3-pin. **Ordercode** FL01150 (1,5 m), FL013 (3 m), FL016 (6 m), FL0110 (10 m), FL0115 (15 m), FL0120 (20 m).
- DAP Audio X-type data cable XLR/M 3-pin > XLR/F 3-pin. **Ordercode** FLX0175 (0,75 m), FLX01150 (1,5 m), FLX013 (3 m), FLX016 (6 m), FLX0110 (10 m).
- DAP Audio cable for the demanding user with exceptional audio-qualities and connector made by Neutrik®. **Ordercode** FL71150 (1,5 m), FL713 (3 m), FL716 (6 m), FL7110 (10 m).
- DAP Audio cable for the demanding user with exceptional audio-qualities and connector made by Neutrik®. **Ordercode** FL7275 (0,75 m), FL72150 (1,5 m), FL723 (3 m), FL726 (6 m), FL7210 (10 m).
- DAP Audio 110 Ohm cable with digital signal transmission. **Ordercode** FL0975 (0,75 m), FL09150 (1,5 m), FL093 (3 m), FL096 (6 m), FL0910 (10 m), FL0915 (15 m), FL0920 (20 m).
- DAP Audio DMX adapter: 5-pin/3-pin. **Ordercode** FLA29.
- DAP Audio DMX adapter: 3-pin/5-pin. **Ordercode** FLA30.

The Magician LED can be operated with a controller in **control mode** or without the controller in **stand-alone mode**.

Control Panel

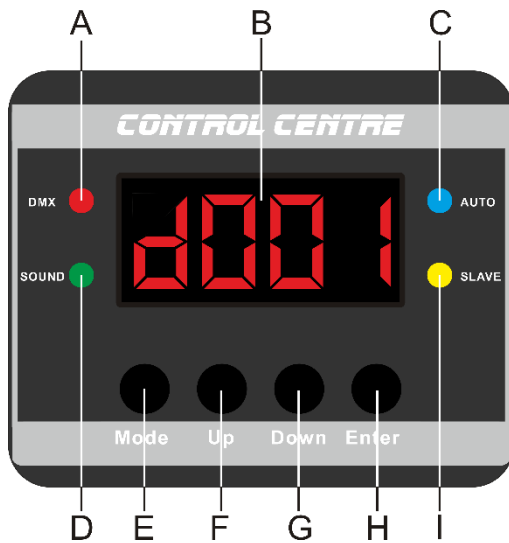

- A) DMX LED
- B) LED display
- C) AUTO LED
- D) SOUND LED
- E) Mode button
- F) Up button
- G) Down button
- H) Enter button
- I) SLAVE LED

Fig. 07

Control Mode

The fixtures are individually addressed on a data-link and connected to the controller. The fixtures respond to the DMX signal from the controller. (When you select the DMX address and save it, the controller will display the saved DMX address, next time.)

DMX Addressing

The control panel on the back side of the device allows you to assign DMX fixture addresses, which is the first channel with which the Magician will respond to the controller.

Please note, when you use the controller, the unit has **28** channels.

When using multiple Magicians, make sure you set the DMX addresses right.

Therefore, the DMX address of the first Magician should be **1(d001)**; the DMX address of the second Magician should be **1+28=29 (d029)**; the DMX address of the third Magician should be **29+28=57 (d057)**, etc. Please, be sure that you do not have any overlapping channels in order to control each Magician correctly. If two or more Magicians are addressed similarly, they will work similarly.

Controlling:

After having addressed all Magician fixtures, you may now start operating these via your lighting controller.

Note: After switching on, the Magician will automatically detect whether DMX 512 data is received or not. If there is no data received at the DMX-input, the "LED" on the control panel will not flash.

If not, the problem may be:

- The XLR cable from the controller is not connected with the input of the Magician.
- The controller is switched off or defective, the cable or connector is defective, or the signal wires are swapped in the input connector.

Note: It is necessary to insert an XLR termination plug (with 120 Ohm) in the last fixture in order to ensure proper transmission on the DMX data link.

Display Off after 60 seconds

When no button is pressed for 60 seconds, the display will turn off.

To light up the display, you have to press the **Mode**, **Enter**, **Up** or **Down** button.

Once you have pressed the button, the display will light up.

Menu Overview

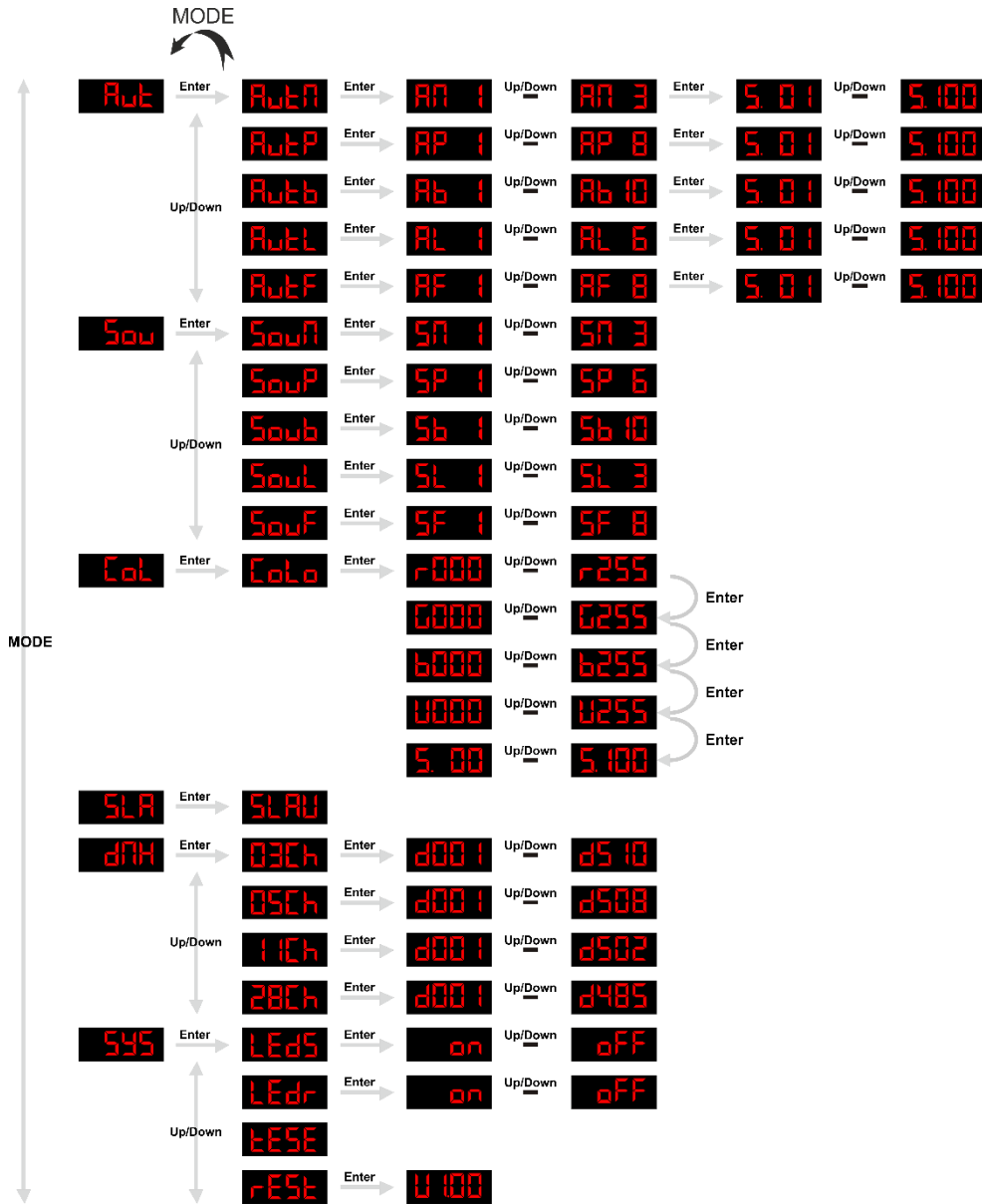

The Magician LED will only show its version number at start-up !

U 100

Main Menu Options

- Aut** Auto Run Programs
- Sou** Sound-controlled Mode
- Col** Static Color Mode
- SLA** Slave Mode
- dMX** DMX Channels / DMX Address
- SYS** System Settings

1. Auto Run Programs

With this menu you can start several Auto run programs.

- 01) Press the **Mode** button until the display shows **Aut**.
- 02) Press the **Enter** button to open this menu.
- 03) Press the **Up** and **Down** buttons to choose between 5 types of built-in programs:

AutA	Auto run mix programs (Wash/Beam/Laser/Strobe)
AutP	Auto run wash programs
AutB	Auto run beam programs
AutL	Auto run laser programs
AutF	Auto run strobe programs

- 04) Choose the desired type and press the **Enter** button again to open the submenu.
- 05) Press the **Up** and **Down** buttons to choose between:

AA Up/Down	AA 3	mix programs
AP Up/Down	AP 8	wash programs
AB Up/Down	AB 10	beam programs
AL Up/Down	AL 6	laser programs
AF Up/Down	AF 8	strobe programs

- 06) Press the **Enter** button again to set the speed of the desired Auto run program.
- 07) Press the **Up** and **Down** buttons to adjust the speed between **5.01** ^{Up/Down} **5.100**, from slow to fast.
- 08) The Magician will immediately start the desired Auto run program.

2. Sound-controlled Mode

With this menu you can set several Sound-controlled programs.

- 01) Press the **Mode** button until the display shows **Sou**.
- 02) Press the **Enter** button to open this menu.
- 03) Press the **Up** and **Down** buttons to choose between 5 types of Sound-controlled programs:

SouA	Sound-controlled mix programs (Wash/Beam/Laser/Strobe)
SouP	Sound-controlled wash programs
SouB	Sound-controlled beam programs
SouL	Sound-controlled laser programs
SouF	Sound-controlled strobe programs

- 04) Choose the desired type and press the **Enter** button again to open the submenu.
- 05) Press the **Up** and **Down** buttons to choose between:

SA Up/Down	SA 3	mix programs
SP Up/Down	SP 6	wash programs
SB Up/Down	SB 10	beam programs
SL Up/Down	SL 3	laser programs
SF Up/Down	SF 8	strobe programs

- 06) Turn on the music and the Magician will immediately start the desired Sound-controlled program.

3. Static Control Mode

With this menu you can manually set a desired color and set the strobe function.

- 01) Press the **Mode** button until the display shows **Col**.
- 02) Press the **Enter** button to open this menu.

	Up/Down		Gradual adjustment red intensity(0-255)
	Up/Down		Gradual adjustment green intensity (0-255)
	Up/Down		Gradual adjustment blue intensity (0-255)
	Up/Down		Gradual adjustment UV intensity (0-255)
	Up/Down		Strobe speed from slow to fast

- 03) Repeatedly press the **Enter** button to scroll through the 4 color options and the strobe function.
- 04) Press the **Up** and **Down** buttons to change the values.
You can combine Red, Green, Blue and UV to create an infinite range of colors (0-255).

4. Slave mode

With this menu you can set the device as a Slave.

- 01) Press the **Mode** button until the display shows **SLA**.
- 02) Press the **Enter** button to activate the slave mode, the display shows **SLAV**.
- 03) If the device has not been set to slave, it is automatically classified as a master device. All slave devices will follow the master movement. If the device has been set to slave, it will react the same as its master device.

5. DMX Channels / DMX Address

With this menu you can choose a DMX configuration and set the DMX address.

- 01) Press the **Mode** button until the display shows **dmx**.
- 02) Press the **Enter** button to open this menu.

	Enter		Up/Down	
	Enter		Up/Down	
	Enter		Up/Down	
	Enter		Up/Down	

- 03) Press the **Up** and **Down** buttons to choose the desired DMX configuration.
- 04) Once you have chosen the desired DMX configuration press the **Enter** button to set the DMX address.
- 05) Press the **Up** and **Down** buttons to select the required address.
- 06) Each DMX configuration has a different maximum number of DMX addresses.

6. System Settings

With this menu you can set several system functions.

- 01) Press the **Mode** button until the display shows **595**.
- 02) Press the **Enter** button to open this menu.
- 03) Press the **Up** and **Down** buttons to choose between 4 settings:

LEd5 LED power saving mode

LEdr LED display reverse









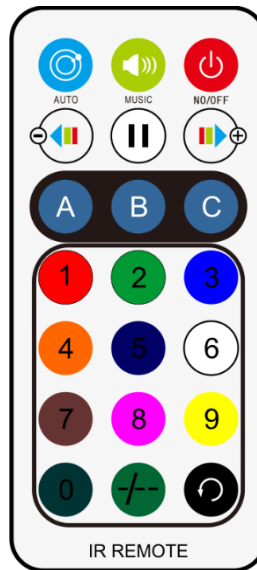



tEST Test mode

rESE Reset to default settings

- 04) If you have chosen **LEd5**, press the **Enter** button to activate the LED power saving mode.
- 05) Press the **Up** and **Down** buttons to choose between **on** ^{Up/Down} **off**.
- 06) If you have chosen **LEdr**, press the **Enter** button to set the display reverse mode.
- 07) Press the **Up** and **Down** buttons to choose between **on** ^{Up/Down} **off**.
- 08) If you have chosen **tEST**, press the **Enter** button to activate the test mode.
- 09) The device will start with a full test of all the features available on the device.
- 10) If you have chosen **rESE**, press the **Enter** button to reset to default settings.
- 11) The display will show its version **V100** and the device settings have been reset.
- 12) The device will start up in the Auto Run Programs mode.

Remote Control



Button	Function	Description
	On / Off	Switch the device ON or OFF
	Auto Mix Mode (Wash/Beam/Laser/Strobe)	Repeatedly press the button to activate/deactivate Mix Auto programs (AM1-AM3)
	Sound-controlled Mix Mode (Wash/Beam/Laser/Strobe)	Repeatedly press the button to activate/deactivate Mix Sound-controlled programs (SM1-SM3)
	Wash LEDs auto mode	Repeatedly press the button to activate/deactivate the Wash LEDs mode programs (AP1-AP8/SP1-SP6)
	Beam LEDs auto mode	Repeatedly press the button to activate/deactivate the Beam LEDs mode programs (Ab1-Ab10/Sb1-Sb10)
	Laser auto mode	Repeatedly press the button to activate/deactivate the Laser mode programs (AL1-AL6/SL1-SL3)
	Pause	Press the button to pause the built-in programs or color change
	Speed	Press one of the buttons to adjust the built-in programs speed. 0 = slow, 9 = fast
	Color settings	Press one of the two buttons to choose the desired built-in color of the Wash LEDs
	Auto/Sound mode switch	Press the button to change the programs Wash  /Beam  /Laser  into Auto or Sound mode

DMX Channels**3 channels****Channel 1 – Device functions (CH2 must be set between 6-255 )**

0-5	No function
6-55	Wash LEDs
56-105	Beam LEDs
106-155	Laser
156-205	Strobe
206-255	Mix (Wash/Beam/Laser/Strobe)

Channel 2 – Built-in programs Wash LEDs (CH1 must be set between 6-55 and CH3 between 0-250 for Auto programs (AP) or 251-255 for Sound programs (SP) )

0-5	No function
6-32	AP1/SP1
33-64	AP2/SP2
65-96	AP3/SP3
97-128	AP4/SP4
129-160	AP5/SP5
161-192	AP6/SP6
193-224	AP7/SP7
225-255	AP8/SP8

Channel 2 – Built-in programs Beam LEDs (CH1 must be set between 56-105 and CH3 between 0-250 for Auto programs (Ab) or 251-255 for Sound programs (Sb) )

0-5	No function
6-30	Ab1/Sb1
31-55	Ab2/Sb2
56-80	Ab3/Sb3
81-105	Ab4/Sb4
106-130	Ab5/Sb5
131-155	Ab6/Sb6
156-180	Ab7/Sb7
181-205	Ab8/Sb8
206-230	Ab9/Sb9
231-255	Ab10/Sb10

Channel 2 – Built-in programs Laser (CH1 must be set between 106-155 and CH3 between 0-250 for Auto programs (AL) or 251-255 for Sound programs (SL) )

0-5	No function
6-46	AL1/SL1
47-88	AL2/SL2
89-130	AL3/SL3
131-172	AL4/SL4
173-214	AL5/SL5
215-255	AL6/SL6

Channel 2 – Built-in programs Strobe (CH1 must be set between 156-205 and CH3 between 0-250 for**Auto programs (AF) or 251-255 for Sound programs (SF) **

0-5	No function
6-32	AF1/SF1
33-64	AF2/SF2
65-96	AF3/SF3
97-128	AF4/SF4
129-160	AF5/SF5
161-192	AF6/SF6
193-224	AF7/SF7
225-255	AF8/SF8

Channel 2 – Built-in programs Mix (CH1 must be set between 206-255 and CH3 between 0-250 for Auto**programs (AM) or 251-255 for Sound programs (SM) **

0-5	No function
6-85	AM1/SM1
86-170	AM2/SM2
171-255	AM3/SM3

Channel 3 – Speed Auto built-in programs/ Sound mode (CH2 must be set between 6-255 

0-250	Gradual speed adjustment Auto programs, from slow to fast
251-255	Activate Sound built-in programs

5 channels**Channel 1 – Built-in programs Wash LEDs (CH5 must be set between 0-250 for Auto programs (AP) or 251-255 for Sound programs (SP) )**

0-5	No function
6-32	AP1/SP1
33-64	AP2/SP2
65-96	AP3/SP3
97-128	AP4/SP4
129-160	AP5/SP5
161-192	AP6/SP6
193-224	AP7/SP7
225-255	AP8/SP8

Channel 2 – Built-in programs Beam LEDs (CH5 must be set between 0-250 for Auto programs (Ab) or 251-255 for Sound programs (Sb) )

0-5	No function
6-30	Ab1/Sb1
31-55	Ab2/Sb2
56-80	Ab3/Sb3
81-105	Ab4/Sb4
106-130	Ab5/Sb5
131-155	Ab6/Sb6
156-180	Ab7/Sb7
181-205	Ab8/Sb8
206-230	Ab9/Sb9
231-255	Ab10/Sb10

Channel 3 – Built-in programs Laser (CH5 must be set between 0-250 for Auto programs (AL) or 251-255 for Sound programs (SL) )

0-5	No function
6-46	AL1/SL1
47-88	AL2/SL2
89-130	AL3/SL3
131-172	AL4/SL4
173-214	AL5/SL5
215-255	AL6/SL6

Channel 4 – Built-in programs Strobe (CH5 must be set between 0-250 for Auto programs (AF) or 251-255 for Sound programs (SF) )

0-5	No function
6-32	AF1/SF1
33-64	AF2/SF2
65-96	AF3/SF3
97-128	AF4/SF4
129-160	AF5/SF5
161-192	AF6/SF6
193-224	AF7/SF7
225-255	AF8/SF8

Channel 5 – Speed Auto built-in programs/ Sound mode**(CH1, CH2, CH3 or CH4 must be set between 6-255 )**

0-250	Gradual speed adjustment Auto programs, from slow to fast
251-255	Activate Sound built-in programs

11 channels

Channel 1 – Red Dimmer intensity Wash LEDs (CH5 must be set between 1-100 )
 0-255 Gradual adjustment Red from 0-100%

Channel 2 – Green Dimmer intensity Wash LEDs (CH5 must be set between 1-100 )
 0-255 Gradual adjustment Green from 0-100%

Channel 3 – Blue Dimmer intensity Wash LEDs (CH5 must be set between 1-100 )
 0-255 Gradual adjustment Blue from 0-100%

Channel 4 – UV Dimmer intensity Wash LEDs (CH5 must be set between 1-100 )
 0-255 Gradual adjustment UV from 0-100%

Channel 5 – Master Dimmer intensity/Strobe Wash LEDs

(CH1, CH2, CH3 or CH4 must be set between 1-255 )

0-100 Dimmer intensity, from dark to brightest
 101-250 Strobe flash frequency, from slow to fast (0-20 Hz)
 251-255 Sound-activated strobe

Channel 6 – Color macro's Beam LEDs

0-5 No function
 6-18 Red
 19-32 Green
 33-46 Blue
 47-60 Amber
 61-74 Red+Green
 75-88 Red+Blue
 89-102 Red+Amber
 103-116 Green+Blue
 117-130 Green+Amber
 131-144 Blue+Amber
 145-158 Red+Green+Blue
 159-172 Red+Green+Amber
 173-186 Red+Blue+Amber
 187-200 Green+Blue+Amber
 201-214 Red+Green+Blue+Amber
 215-228 Color change program 1
 229-242 Color change program 2
 243-255 Color change program 3

Channel 7 – Strobe Beam LEDs (CH6 must be set between 6-214 )

0-5 No function
 6-250 Strobe flash frequency, from slow to fast (0-20 Hz)
 251-255 Sound-activated strobe

Channel 7 – Speed Color change / Sound mode Beam LEDs (CH6 must be set between 215-255 )

0-250 Gradual speed adjustment Color change programs, from slow to fast
 251-255 Activate Sound Color change programs

Channel 8 – Laser functions (when CH8 is set between 132-255, CH9 must be set between 6-250)

0-5	No function
6-48	Red laser on
49-89	Green laser on
90-131	Red + Green laser on
132-173	Red laser flashes + Green laser on
174-215	Red laser on + Green laser flashes
216-255	Red + Green laser flash

Channel 9 – Strobe Laser (CH8 must be set between 6-255)

0-5	No function
6-250	Strobe flash frequency, from slow to fast (0-20 Hz)
251-255	Sound-activated strobe

Channel 10 – Rotation effect Red+Green Laser (CH8 must be set between 6-255)

0	No function
1-127	Clockwise rotation, from slow to fast
128	Stop
129-255	Counterclockwise rotation, from slow to fast

Channel 11 – Strobe LEDs

0-5	No function
6-10	Strobe LEDs on
11-250	Strobe flash frequency, from slow to fast (0-20 Hz)
251-255	Sound-activated strobe

28 channels

Channel 1 – Red Dimmer intensity Wash LED 1

(CH5 must be set between 1-100 )

0-255	Gradual adjustment Red from 0 – 100%
-------	--------------------------------------

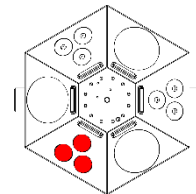

Channel 2 – Green Dimmer intensity Wash LED 1

(CH5 must be set between 1-100 )

0-255	Gradual adjustment Green from 0 – 100%
-------	--

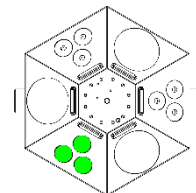

Channel 3 – Blue Dimmer intensity Wash LED 1

(CH5 must be set between 1-100 )

0-255	Gradual adjustment Blue from 0 – 100%
-------	---------------------------------------

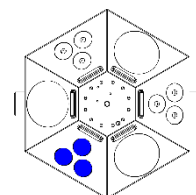

Channel 4 – UV Dimmer intensity Wash LED 1

(CH5 must be set between 1-100 ⚠)

0-255 Gradual adjustment UV from 0 – 100%

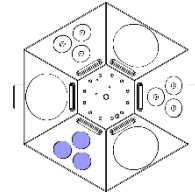

Channel 5 – Master Dimmer intensity/Strobe Wash LED 1

(CH1, CH2, CH3 or CH4 must be set between 1-255 ⚠)

0-100 Dimmer intensity, from dark to brightest

101-250 Strobe flash frequency, from slow to fast (0-20 Hz)

251-255 Sound-activated strobe

Channel 6 – Red Dimmer intensity Wash LED 2

(CH10 must be set between 1-100 ⚠)

0-255 Gradual adjustment Red from 0 – 100%

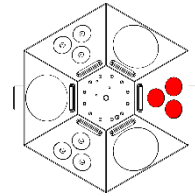

Channel 7 – Green Dimmer intensity Wash LED 2

(CH10 must be set between 1-100 ⚠)

0-255 Gradual adjustment Green from 0 – 100%

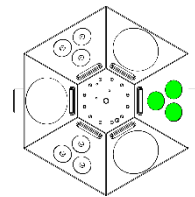

Channel 8 – Blue Dimmer intensity Wash LED 2

(CH10 must be set between 1-100 ⚠)

0-255 Gradual adjustment Blue from 0 – 100%

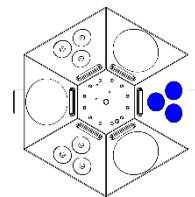

Channel 9 – UV Dimmer intensity Wash LED 2

(CH10 must be set between 1-100 ⚠)

0-255 Gradual adjustment UV from 0 – 100%

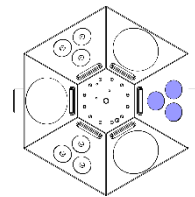

Channel 10 – Master Dimmer intensity/Strobe Wash LED 2

(CH6, CH7, CH8 or CH9 must be set between 1-255 ⚠)

0-100	Dimmer intensity, from dark to brightest
101-250	Strobe flash frequency, from slow to fast (0-20 Hz)
251-255	Sound-activated strobe

Channel 11 – Red Dimmer intensity Wash LED 3

(CH15 must be set between 1-100 ⚠)

0-255	Gradual adjustment Red from 0 – 100%
-------	--------------------------------------

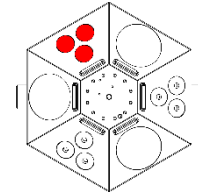

Channel 12 – Green Dimmer intensity Wash LED 3

(CH15 must be set between 1-100 ⚠)

0-255	Gradual adjustment Green from 0 – 100%
-------	--

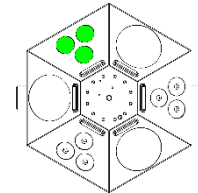

Channel 13 – Blue Dimmer intensity Wash LED 3

(CH15 must be set between 1-100 ⚠)

0-255	Gradual adjustment Blue from 0 – 100%
-------	---------------------------------------

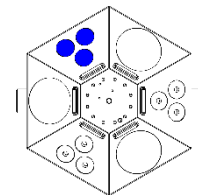

Channel 14 – UV Dimmer intensity Wash LED 3

(CH15 must be set between 1-100 ⚠)

0-255	Gradual adjustment UV from 0 – 100%
-------	-------------------------------------

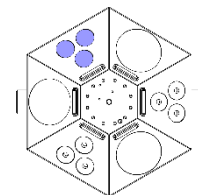

Channel 15 – Master Dimmer intensity/Strobe Wash LED 3

(CH11, CH12, CH13 or CH14 must be set between 1-255 ⚠)

0-100	Dimmer intensity, from dark to brightest
101-250	Strobe flash frequency, from slow to fast (0-20 Hz)
251-255	Sound-activated strobe

Channel 16 – Color macro's Beam LED 1

0-5	No function
6-18	Red
19-32	Green
33-46	Blue
47-60	Amber
61-74	Red+Green
75-88	Red+Blue
89-102	Red+Amber
103-116	Green+Blue
117-130	Green+Amber
131-144	Blue+Amber
145-158	Red+Green+Blue
159-172	Red+Green+Amber
173-186	Red+Blue+Amber
187-200	Green+Blue+Amber
201-214	Red+Green+Blue+Amber
215-228	Color change program 1
229-242	Color change program 2
243-255	Color change program 3

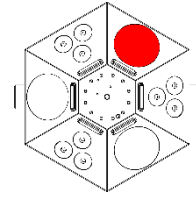

Channel 17 – Strobe Beam LED 1 (CH16 must be set between 6-214)

0-5	No function
6-250	Strobe flash frequency, from slow to fast (0-20 Hz)
251-255	Sound-activated strobe

Channel 17 – Speed Color change / Sound mode Beam LED 1 (CH16 must be set between 215-255)

0-250	Gradual speed adjustment Color change programs, from slow to fast
251-255	Activate Sound Color change programs

Channel 18 – Color macro's Beam LED 2

0-5	No function
6-18	Red
19-32	Green
33-46	Blue
47-60	Amber
61-74	Red+Green
75-88	Red+Blue
89-102	Red+Amber
103-116	Green+Blue
117-130	Green+Amber
131-144	Blue+Amber
145-158	Red+Green+Blue
159-172	Red+Green+Amber
173-186	Red+Blue+Amber
187-200	Green+Blue+Amber
201-214	Red+Green+Blue+Amber
215-228	Color change program 1
229-242	Color change program 2
243-255	Color change program 3

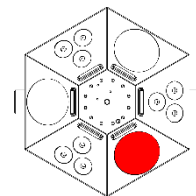

Channel 19 – Strobe Beam LED 2 (CH18 must be set between 6-214)

0-5	No function
6-250	Strobe flash frequency, from slow to fast (0-20 Hz)
251-255	Sound-activated strobe

Channel 19 – Speed Color change / Sound mode Beam LED 2 (CH18 must be set between 215-255)

0-250	Gradual speed adjustment Color change programs, from slow to fast
251-255	Activate Sound Color change programs

Channel 20 – Color macro's Beam LED 3

0-5	No function
6-18	Red
19-32	Green
33-46	Blue
47-60	Amber
61-74	Red+Green
75-88	Red+Blue
89-102	Red+Amber
103-116	Green+Blue
117-130	Green+Amber
131-144	Blue+Amber
145-158	Red+Green+Blue
159-172	Red+Green+Amber
173-186	Red+Blue+Amber
187-200	Green+Blue+Amber
201-214	Red+Green+Blue+Amber
215-228	Color change program 1
229-242	Color change program 2
243-255	Color change program 3

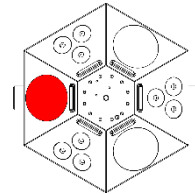

Channel 21 – Strobe Beam LED 3 (CH20 must be set between 6-214)

0-5	No function
6-250	Strobe flash frequency, from slow to fast (0-20 Hz)
251-255	Sound-activated strobe

Channel 21 – Speed Color change / Sound mode Beam LED 3 (CH20 must be set between 215-255)

0-250	Gradual speed adjustment Color change programs, from slow to fast
251-255	Activate Sound Color change programs

Channel 22 – Laser functions (when CH22 is set between 132-255, CH23 must be set between 6-250)

0-5	No function
6-48	Red laser on
49-89	Green laser on
90-131	Red + Green laser on
132-173	Red laser flashes + Green laser on
174-215	Red laser on + Green laser flashes
216-255	Red + Green laser flash

Channel 23 – Strobe Laser (CH22 must be set between 6-255)

0-5	No function
6-250	Strobe flash frequency, from slow to fast (0-20 Hz)
251-255	Sound-activated strobe

Channel 24 – Rotation effect Red+Green Laser (CH22 must be set between 6-255 )

0	No function
1-127	Clockwise rotation, from slow to fast
128	Stop
129-255	Counterclockwise rotation, from slow to fast

Channel 25 – Strobe LEDs

0-5	No function
6-10	Strobe LEDs on
11-250	Strobe flash frequency, from slow to fast (0-20 Hz)
251-255	Sound-activated strobe

Channel 26 – Device functions (CH27 must be set between 6-255 )

0-5	No function
6-55	Wash LEDs
56-105	Beam LEDs
106-155	Laser
156-205	Strobe
206-255	Mix (Wash/Beam/Laser/Strobe)

Channel 27 – Built-in programs Wash LEDs (CH26 must be set between 6-55 and CH28 between 0-250 for Auto programs (AP) or 251-255 for Sound programs (SP) )

0-5	No function
6-32	AP1/SP1
33-64	AP2/SP2
65-96	AP3/SP3
97-128	AP4/SP4
129-160	AP5/SP5
161-192	AP6/SP6
193-224	AP7/SP7
225-255	AP8/SP8

Channel 27 – Built-in programs Beam LEDs (CH26 must be set between 56-105 and CH28 between 0-250 for Auto programs (Ab) or 251-255 for Sound programs (Sb) )

0-5	No function
6-30	Ab1/Sb1
31-55	Ab2/Sb2
56-80	Ab3/Sb3
81-105	Ab4/Sb4
106-130	Ab5/Sb5
131-155	Ab6/Sb6
156-180	Ab7/Sb7
181-205	Ab8/Sb8
206-230	Ab9/Sb9
231-255	Ab10/Sb10

Channel 27 – Built-in programs Laser (CH26 must be set between 106-155 and CH28 between 0-250 for Auto programs (AL) or 251-255 for Sound programs (SL) )

0-5	No function
6-46	AL1/SL1
47-88	AL2/SL2
89-130	AL3/SL3
131-172	AL4/SL4
173-214	AL5/SL5
215-255	AL6/SL6

Channel 27 – Built-in programs Strobe (CH26 must be set between 156-205 and CH28 between 0-250 for Auto programs (AF) or 251-255 for Sound programs (SF) ⚠)

0-5	No function
6-32	AF1/SF1
33-64	AF2/SF2
65-96	AF3/SF3
97-128	AF4/SF4
129-160	AF5/SF5
161-192	AF6/SF6
193-224	AF7/SF7
225-255	AF8/SF8

Channel 27 – Built-in programs Mix (CH26 must be set between 206-255 and CH28 between 0-250 for Auto programs (AM) or 251-255 for Sound programs (SM) ⚠)

0-5	No function
6-85	AM1/SM1
86-170	AM2/SM2
171-255	AM3/SM3

Channel 28 – Speed Auto built-in programs/ Sound mode (CH27 must be set between 6-255 ⚠)

0-250	Gradual speed adjustment Auto programs, from slow to fast
251-255	Activate Sound built-in programs

Maintenance

The operator has to make sure that safety-related and machine-technical installations are to be inspected by an expert after every year in the course of an acceptance test.

The operator has to make sure that safety-related and machine-technical installations are to be inspected by a skilled person once a year.

The following points have to be considered during the inspection:

- 01) All screws used for installing the device or parts of the device have to be tightly connected and must not be corroded.
- 02) There may not be any deformations on housings, fixations and installation spots.
- 03) Mechanically moving parts like axles, eyes and others may not show any traces of wearing.
- 04) The electric power supply cables must not show any damages or material fatigue.

The Magician LED requires almost no maintenance. However, you should keep the unit clean.

Otherwise, the fixture's light-output will be significantly reduced. Disconnect the mains power supply, and then wipe the cover with a damp cloth. Do not immerse in liquid. Wipe lens clean with glass cleaner and a soft cloth. Do not use alcohol or solvents.

The front lens will require weekly cleaning, as smoke-fluid tends to build up residues, reducing the light-output very quickly.

Keep connections clean. Disconnect electric power, and then wipe the DMX and audio connections with a damp cloth. Make sure connections are thoroughly dry before linking equipment or supplying electric power.

Replacing the Fuse

Power surges, short-circuit or inappropriate electrical power supply may cause a fuse to burn out.

If the fuse burns out, the product will not function whatsoever. If this happens, follow the directions below:

- 01) Unplug the unit from electric power source.
- 02) Insert a flat-headed screwdriver into a slot in the fuse cover. Gently pry up the fuse cover. the fuse will come out.
- 03) Remove the used fuse. If brown or unclear, it is burned out.
- 04) Insert the replacement fuse into the holder. Reinsert the fuse cover. Be sure to use a fuse of the same type and specification. See the product specification label for details.

Troubleshooting

This troubleshooting guide is meant to help solve simple problems.

If a problem occurs, carry out the steps below in sequence until a solution is found. Once the unit operates properly, do not carry out following steps.

No Light

If the light effect does not operate properly, refer servicing to a technician.

Suspect four potential problem areas as: the power supply, the Laser, LEDs, the fuse.

- 01) Power supply. Check that the unit is plugged into an appropriate power supply.
- 02) The laser. Return the Magician to your Showtec dealer.
- 03) The Wash LEDs, Strobe LEDs and the Beam LEDs. Return the Magician to your Showtec dealer.
- 04) The fuse. Replace the fuse. See page 32 for replacing the fuse.
- 05) If all of the above appears to be O.K., plug the unit in again.
- 06) If you are unable to determine the cause of the problem, do not open the Magician, as this may damage the unit and the warranty will become void.
- 07) Return the device to your Showtec dealer.

No Response to DMX

Suspect the DMX cable or connectors, a controller malfunction, a light effect DMX card malfunction.

- 01) Check the DMX setting. Make sure that DMX addresses are correct.
- 02) Check the DMX cable: Unplug the unit; change the DMX cable; then reconnect to electrical power. Try your DMX control again.
- 03) Determine whether the controller or light effect is at fault. Does the controller operate properly with other DMX products? If not, take the controller in for repair. If so, take the DMX cable and the light effect to a qualified technician.

The fixture does not work, no laser and the fan does not work

- 01) Check the connected power and main fuse.
- 02) Check the mains voltage on the main connector.

The fixture is power on, but no laser coming out from aperture

- 01) Check the laser aperture cover.
- 02) Check the key switch.
- 03) Check the remote interlock or interlock connector.
- 04) Wait for at least 30 minutes to warm up in low temperature.
- 05) Check whether it is in music mode without sound signal.
- 06) Check whether it is in Slave mode.
- 07) Check whether it is in DMX mode without a DMX signal being present.

The laser effect power is very weak

- 01) Wait for at least 30 minutes to warm up in low temperature.
- 02) Clean the scanner mirror with alcohol.
- 03) Clean the aperture glass with alcohol.
- 04) Check whether it is in DMX mode with a high strobe frequency.

The laser is on, but the pattern is not moving

- 01) Check to see whether it is in Music/Sound mode without detecting sound signal.
- 02) Check to see whether it is in DMX mode.
- 03) Try to change the fixture to another stand-alone mode.
- 04) Try to control the fixture via DMX to see the laser effect system.

Problem	Probable cause(s)	Solution
One or more fixtures do not function at all	No power to the fixture	<ul style="list-style-type: none"> • Check if power is switched on and cables are plugged in
	Primary fuse blown.	<ul style="list-style-type: none"> • Replace fuse.
Fixtures reset correctly, but all respond erratically or not at all to the controller	The controller is not connected.	<ul style="list-style-type: none"> • Connect controller.
	3-pin XLR Out of the controller does not match XLR Out of the first fixture on the link (i.e. signal is reversed)	<ul style="list-style-type: none"> • Install a phase reversing cable between the controller and the first fixture on the link
Fixtures reset correctly, but some respond erratically or not at all to the controller	Poor data quality	<ul style="list-style-type: none"> • Check data quality. If much lower than 100 percent, the problem may be a bad data link connection, poor quality or broken cables, missing termination plug, or a defective fixture disturbing the link
	Bad data link connection	<ul style="list-style-type: none"> • Inspect connections and cables. Correct poor connections. Repair or replace damaged cables
	Data link not terminated with 120 Ohm termination plug	<ul style="list-style-type: none"> • Insert termination plug in output jack of the last fixture on the link
	Incorrect addressing of the fixtures	<ul style="list-style-type: none"> • Check address setting
	One of the fixtures is defective and disturbs data transmission on the link	<ul style="list-style-type: none"> • Bypass one fixture at a time until normal operation is restored: unplug both connectors and connect them directly together. • Have the defective fixture serviced by a qualified technician
	3-pin XLR Out on the fixtures does not match (pins 2 and 3 reversed)	<ul style="list-style-type: none"> • Install a phase-reversing cable between the fixtures or swap pin 2 and 3 in the fixture that behaves erratically
Shutter closes suddenly	The laser diode has lost its index position and the fixture is resetting the effect.	<ul style="list-style-type: none"> • Contact a technician for servicing the problem persists.
No light or LEDs or Laser cuts out intermittently	Fixture is too hot	<ul style="list-style-type: none"> • Allow the fixture to cool down • Clean the fan • Make sure air vents in control panel and the front lens are not blocked • Turn up the air conditioning
	LEDs or Laser damaged	<ul style="list-style-type: none"> • Disconnect the fixture and return it to your dealer
	The power supply settings do not match local AC voltage and frequency	<ul style="list-style-type: none"> • Disconnect fixture. Check settings and correct if necessary

Product Specifications

Model:	Showtec Magician LED
Input Voltage:	100-240V AC, 50/60Hz
Power consumption:	90W (full output)
DMX linking:	30 pcs
Power linking @110V	10 pcs
Power linking @240V	20 pcs
Protection rate:	IP-20
Fuse:	T1.6L/250V
Dimensions:	350 x 320 x 185 mm (LxWxH) (incl. bracket)
Weight:	3,1 kg
Operating and Programming:	
Signal pin OUT:	Pin 1 (earth), pin 2 (-), pin 3 (+)
DMX Mode:	3, 5, 11 or 28 channels
Signal input:	3-pin DMX IN
Signal output:	3-pin DMX OUT
Electro-mechanical effects:	
Wash LED effect:	9 x 4W RGB-UV LEDs
Beam LED effect:	3 x Beam LEDs (8 x 0,75W Red, 6 x 0,75W Green, 6 x 0,75W Blue, 8 x 0,75W Amber)
Laser effect:	Colors: Red, Green
	Power: 130mW (100mW 650nm Red, 30mW 532nm Green)
	Class: 2M
	Safety Features: Key switch, Interlock, Safety eye
	Safety: EN/IEC 60825-1 Ed 2, 2007-03
Strobe effect:	12 x 0,5W White 5730 LEDs
Housing:	Die-cast black aluminum
DMX-control:	via standard DMX-controller
On Board:	4-digit LED display for easy setup
Control:	Auto, Sound-controlled, Static color, Master/Slave, DMX
Connections:	IEC connectors (IN/OUT), 3-pin XLR (IN/OUT)
Cooling:	Fans/Convection
Max. ambient temperature t_a :	40°C
Max. housing temperature t_B :	80°C
Minimum distance:	
Minimum distance from flammable surfaces:	0,5 m
Minimum distance to lighted object:	1 m

Design and product specifications are subject to change without prior notice.



Website: www.Showtec.info

Email: service@highlite.nl

Dimensions

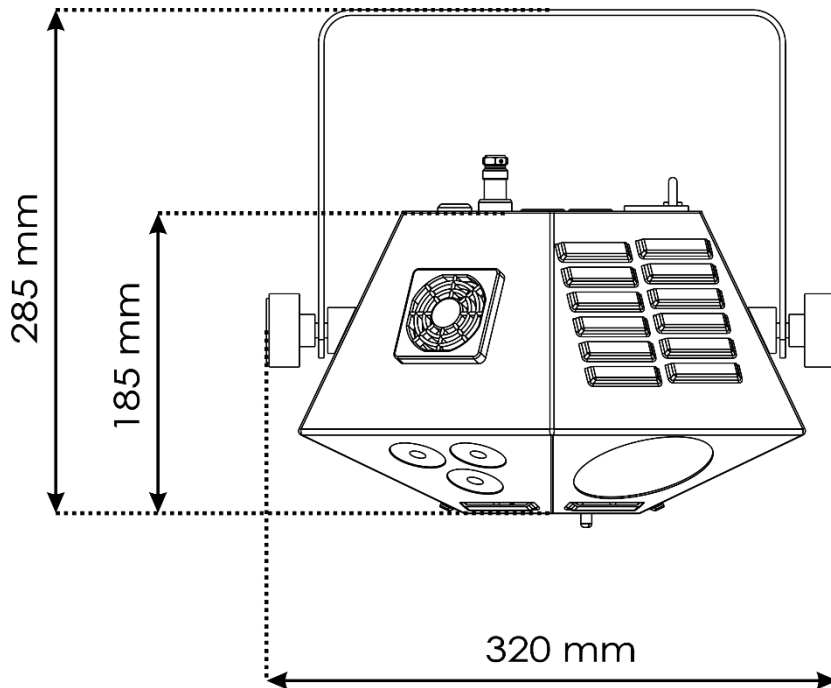
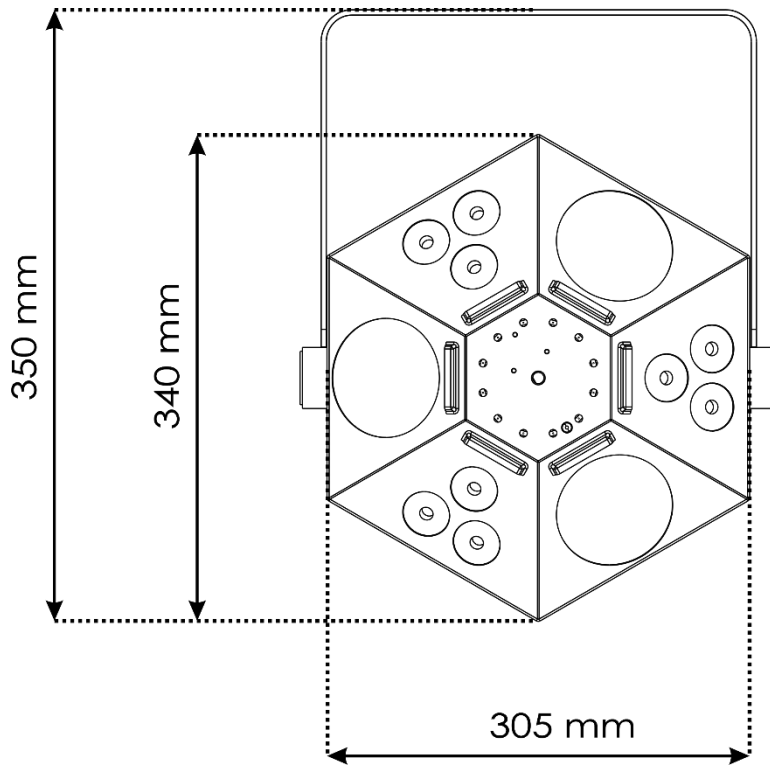



©2018 Showtec