

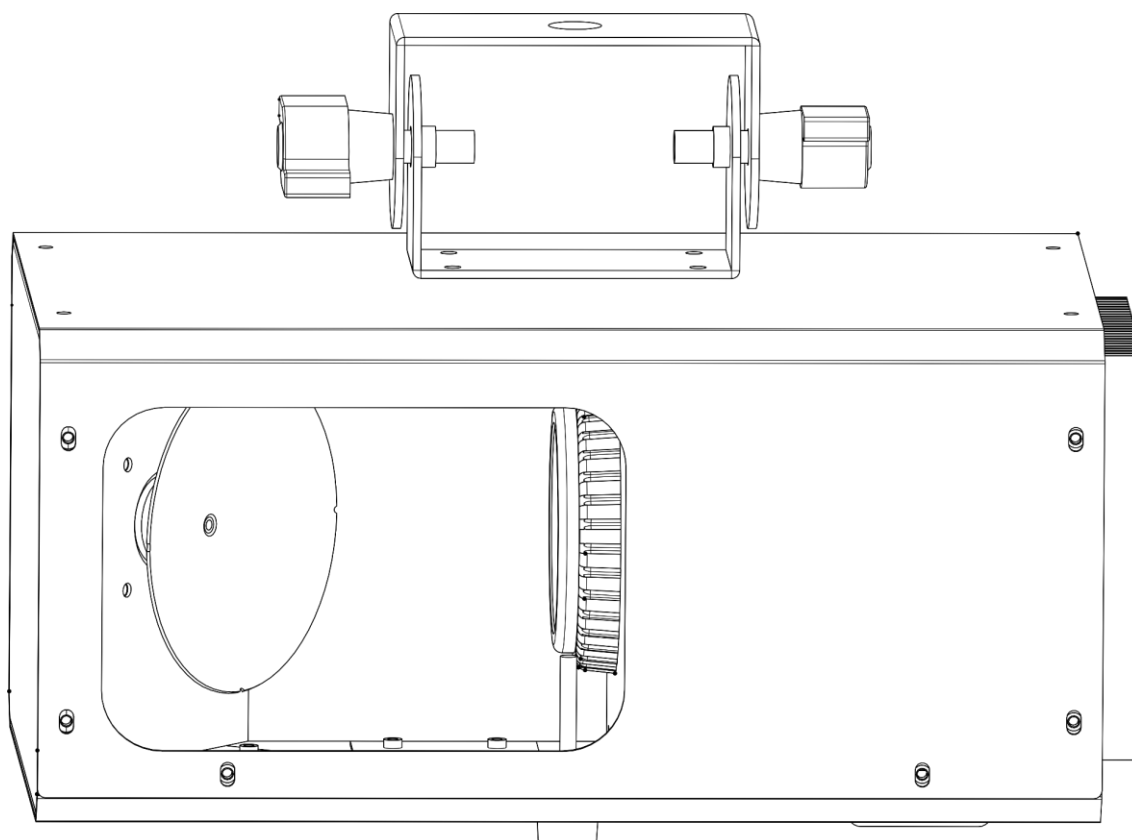

MANUAL



ENGLISH

Dreammoon

V1

Ordercode: 43167

Table of contents

Warning	2
Safety Instructions	2
Operating Determinations	4
Rigging	5
Connection with the mains.....	5
Return Procedure	6
Claims.....	6
 Description of the device	7
Overview.....	7
Frontside.....	8
Backside.....	8
 Installation	9
 Set Up and Operation	9
Control Modes	9
One Dreammoon (Built-in programs, Manual)	9
One Dreammoon (Sound-controlled)	9
Multiple Dreammoons (Master/Slave control)	10
Multiple Dreammoons (DMX Control).....	11
Fixture Linking	12
Data Cabling	12
Control Panel	13
Control Mode	13
DMX Addressing	13
Menu Overview	14
Main Menu Options	15
DMX address.....	15
1. DMX Addressing.....	15
2. Channel Mode.....	15
3. Slave/Reverse Slave Mode	16
4. Master/Slave Mode.....	16
5. Show Mode.....	16
6. Sound control Mode	16
7. Sensitivity Mode	17
8. Blackout/DMX Fail Mode	17
9. Backlight.....	17
10. Display settings.....	17
11. Manual	18
12. Temperature	18
13. Lifetime	18
14. Firmware Version.....	18
DMX Channels	19
5 channels.....	19
9 channels.....	19
 Maintenance	20
Replacing the Fuse	20
Replacing the Gobo	21
 Troubleshooting	22
No Light.....	22
No Response to DMX.....	22
 Product Specifications	24
 Dimensions	25

Warning



**For your own safety, please read this user manual carefully
before your initial start-up!**



Unpacking Instructions

Immediately upon receiving this product, carefully unpack the carton and check the contents to ensure that all parts are present, and have been received in good condition. Notify the dealer immediately and retain packing material for inspection if any parts appear damaged from shipping or the carton itself shows signs of mishandling. Save the carton and all packing materials. In the event that a fixture must be returned to the factory, it is important that the fixture be returned in the original factory box and packing.

Your shipment includes:

- Showtec Dreammoon
- IEC power cable (1,5 m)
- User manual

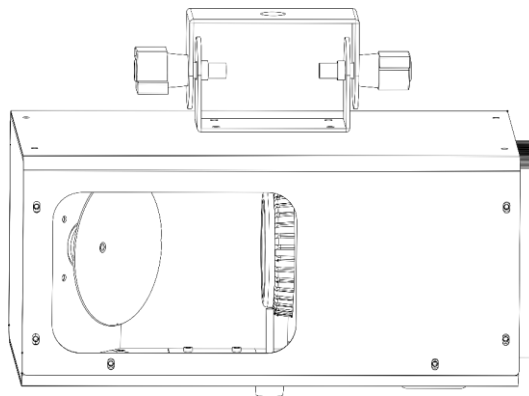

LED Expected Lifespan

LEDs gradually decline in brightness over time. HEAT is the dominant factor that leads to the acceleration of this decline. Packaged in clusters, LEDs exhibit higher operating temperatures than in ideal or singular optimum conditions. For this reason, when all color LEDs are used at their fullest intensity, life of the LEDs is significantly reduced. If improving the lifespan is of higher priority, place care in providing for lower operational temperatures. This may include climatic-environmental and the reduction of overall projection intensity.



CAUTION!

**Keep this device away from rain and moisture!
Unplug mains lead before opening the housing!**



Safety Instructions

Every person involved with the installation, operation and maintenance of this device has to:

- be qualified
- follow the instructions of this manual



**CAUTION! Be careful with your operations.
With a dangerous voltage you can suffer
a dangerous electric shock when touching the wires!**



Before the initial start-up, please make sure that there is no damage caused by transportation. Should there be any, consult your dealer and do not use the device.

To maintain perfect condition and to ensure a safe operation, it is absolutely necessary for the user to follow the safety instructions and warning notes contained in this manual.

Please consider that damages caused by manual modifications to the device are not subject to warranty.

This device contains no user-serviceable parts. Refer servicing to qualified technicians only.

IMPORTANT:

The manufacturer will not accept liability for any resulting damages caused by the non-observance of this manual or any unauthorized modification to the device.

- Never let the power cord come into contact with other cables! Handle the power cord and all connections with the mains with particular caution!
- Never modify, bend, mechanically strain, put pressure on, pull or heat up the power cord.
- Never strain the cable insert or the female part in the device. There must always be sufficient cable going to the device. Otherwise, the cable will be damaged, which can cause serious damage.
- Never remove warning or informative labels from the unit.
- Never use anything to cover the ground contact.
- Never lift the device holding it by the projector-head, as the mechanics may be damaged. Always hold the device by the transport handles.
- Never place any material over the LEDs or lens.
- Never look directly into the light source.
- Never leave any cables lying around.
- Never use the device during thunderstorms, unplug the device immediately.
- Never leave various parts of the packaging (plastic bags, polystyrene foam, nails, etc.) within children's reach, as they are potential sources of danger.
- Never aim the laser beam at people or animals!
- Never point a laser at aircraft, this is a federal offense.
- Never point unterminated laser beams into the sky.
- Never open the laser housing. The high laser power levels inside of the protective housing can start fires, burn skin and will cause instant eye injury.
- Do not insert objects into air vents.
- Do not connect this device to a dimmer pack.
- Do not open the device and do not modify the device.
- Do not point lasers at highly reflective surfaces such as windows, mirrors and shiny metal. Even laser reflections can be hazardous.
- Do not expose the output optic (aperture) to cleaning chemicals.
- Do not use the laser if the laser appears to be emitting only one or two beams.
- Do not use the laser if housing is damaged or open, or if optics appear damaged in any way.
- Do not operate laser without first reading and understanding all safety and technical data in this manual. Never look into the laser aperture or laser beams.
- Do not switch the device on and off in short intervals, as this will reduce the device's life.
- Do not touch the device's housing bare-handed during its operation (housing becomes very hot). Allow the device to cool for at least 5 minutes before handling.
- Do not shake the device. Avoid brute force when installing or operating the device.
- After set up and prior to public use, test laser to ensure proper function. Do not use the laser if any defect is detected. Do not use, if the laser emits only one or two laser beams rather than dozens/hundreds, as this could indicate damage to the diffraction grating optic, and could allow emission of higher laser levels.
- Only use the device indoors, avoid contact with water or other liquids.
- Only operate the device after having checked if the housing is firmly closed and all screws are tightly fastened.
- Only operate the device after having familiarized with its functions.
- Always check the regulations when using a class 3R laser product.
- Always check and position the laser before anybody enters the room, when the laser is facing an area with people.

- Avoid flames and do not put close to flammable liquids or gases.
- Always keep the case closed while operating.
- Always allow a free air space of at least 50 cm around the unit for ventilation.
- Always disconnect power from the mains, when device is not used or before cleaning! Only handle the power cord holding it by the plug. Never pull out the plug by tugging the power cord.
- Make sure that the device is not exposed to extreme heat, moisture or dust.
- Make sure that the available voltage is not higher than stated on the rear panel.
- Make sure that the power cord is never crimped or damaged. Check the device and the power cord from time to time.
- Make sure that the core diameter of extension cords and power cords is sufficient for the required power consumption of the device.
- If the external cable is damaged, it has to be replaced by a qualified technician.
- If the lens or LEDs are obviously damaged, it has to be replaced to prevent its functions from being impaired, due to cracks or deep scratches.
- If device was dropped or struck, disconnect mains power supply immediately. Have a qualified engineer inspect for safety before operating.
- If the device has been exposed to drastic temperature fluctuation (e.g. after transportation), do not switch it on immediately. The arising condensation water might damage your device. Leave the device switched off until it has reached room temperature.
- If your Showtec device fails to work properly, discontinue the use immediately. Pack the unit securely (preferably in the original packing material), and return it to your Showtec dealer for service.
- For adult use only. The device must be installed beyond the reach of children. Never leave the unit running unattended.
- Never attempt to bypass the thermostatic switch or fuses.
- For replacement use fuses of same type and rating only.
- The user is responsible for correct positioning and operating of the device. The manufacturer will not accept liability for damages caused by the misuse or incorrect installation of this device.
- This device falls under protection class I. Therefore it is essential to connect the yellow/green conductor to earth.
- Repairs, servicing and electric connection must be carried out by a qualified technician.
- WARRANTY: Till one year after date of purchase.



CAUTION! Eyedamages!!!
Avoid looking directly into the lightsource!!!
(meant especially for epileptics)!!!



Operating Determinations

- This device is not designed for permanent operation. Consistent operation breaks will ensure that the device will serve you for a long time without defects.
- The minimum distance between light output and the illuminated surface must be bigger than 1 meter. (This distance may differ depending on the model. The exact minimum distance will be mentioned in the corresponding manual.)
- To eliminate wear and improve lifespan, during periods of non-use, completely disconnect from power via breaker or by unplugging.
- The maximum ambient temperature $t_a = 35^\circ\text{C}$ must never be exceeded.
- The relative humidity must not exceed 50 % with an ambient temperature of 35°C .
- If this device is operated in any other way than the one described in this manual, the product may suffer damages and the warranty becomes void.
- Any other operation may lead to dangers like short-circuit, burns, electric shock, crash, etc.

You endanger your own safety and the safety of others!

Rigging

Please follow the European and national guidelines concerning rigging, trussing and all other safety issues.

Do not attempt the installation yourself !

Always let the installation be carried out by an authorized dealer !

Procedure:

- If the Dreammoon is lowered from the ceiling or high joists, professional trussing systems have to be used.
- Use a clamp to mount the Dreammoon, with the mounting bracket, to the trussing system.
- The Dreammoon must never be fixed swinging freely in the room.
- The installation must always be secured with a safety attachment, e.g. an appropriate safety net or safety cable.
- When rigging, derigging or servicing the Dreammoon, always make sure, that the area below the installation site is secured and that there are not any unauthorized people around.

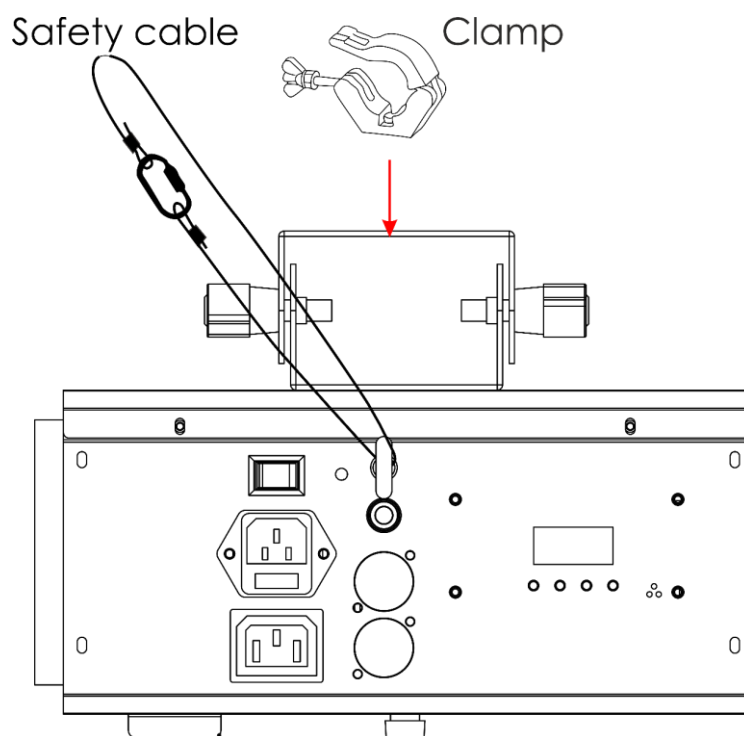

The Dreammoon can be placed on a flat stage floor or mounted to any kind of truss with a clamp.

Improper installation can cause serious injuries and/or damage of property!

Connection with the mains

Connect the device to the mains with the power-plug.

Always check if the right color cable is connected to the right place.

International	EU Cable	UK Cable	US Cable	Pin
L	BROWN	RED	YELLOW/COPPER	PHASE
N	BLUE	BLACK	SILVER	NEUTRAL
	YELLOW/GREEN	GREEN	GREEN	PROTECTIVE GROUND

Make sure that the device is always properly connected to the earth!

Improper installation can cause serious injuries and/or damage of property!

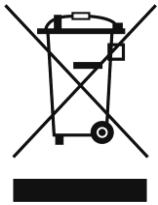

Return Procedure

Returned merchandise must be sent prepaid and in the original packing, call tags will not be issued. Package must be clearly labeled with a Return Authorization Number (RMA number). Products returned without an RMA number will be refused. Highlite will not accept the returned goods or any responsibility. Call Highlite 0031-455667723 or mail aftersales@highlite.com and request an RMA prior to shipping the fixture. Be prepared to provide the model number, serial number and a brief description of the cause of the return. Be sure to properly pack fixture as any shipping damage resulting from inadequate packaging is the customer's responsibility. Highlite reserves the right to use its own discretion to repair or replace product(s). As a suggestion, proper UPS packing or double-boxing is always a safe method to use.

Note: If you are given an RMA number, please include the following information on a piece of paper inside the box:

- 01) Your name.
- 02) Your address.
- 03) Your phone number.
- 04) A brief description of the symptoms.

Claims

The client has the obligation to check the delivered goods immediately upon delivery for any shortcomings and/or visible defects, or perform this check after our announcement that the goods are at their disposal. Damage incurred in shipping is the responsibility of the shipper; therefore the damage must be reported to the carrier upon receipt of merchandise.

It is the customer's responsibility to notify and submit claims with the shipper in the event that the fixture is damaged due to shipping. Transportation damage has to be reported to us within one day after receipt of the delivery.

Any return shipment has to be made post-paid at all times. Return shipments must be accompanied with a letter defining the reason for return shipment. Non-prepaid return shipments will be refused, unless agreed otherwise in writing.

Complaints against us must be made known in writing or by fax within 10 working days after receipt of the invoice. After this period, complaints will not be handled anymore.

Complaints will only be considered if the client has so far complied with all parts of the agreement, regardless of the agreement of which the obligation is resulting.

Description of the device

Features

The Dreammoon is a dynamic and highly decorative effect light. It can be used both as a background effect or beam effect. Due to the highly reflective and optical advanced mirror dish the Dreammoon produces crisp, vivid colours and beams at your gig.

The Dreammoon has 1 glass pattern pre-mounted. A further 3 glass patterns are included and can be easily exchanged in order to customize your Dreammoon and create your desired effect.

- Input voltage: 100-240V AC, 50/60Hz
- Power consumption: 68W
- DMX channels: 5 or 9 channels
- 4-digit LED display for easy setup
- Control modes: Built-in programs, Manual, Sound-controlled, Master/Slave, DMX
- Stunning built-in light shows
- Wide beam-angle
- Multipurpose effect
- LED Beams: 1x 60W RGBW 4-in-1 LEDs
- Control protocol: DMX-512
- Protection rate: IP20
- Housing: Die-cast black aluminum
- Connections: IEC connectors IN/OUT, 3-pin XLR IN/OUT
- Fuse: T1AL/250V
- Dimensions: 275 x 200 x 191 mm (LxWxH)
- Weight: 3,6 kg

Note: Knowledge of DMX is required to fully utilize this unit.

Overview

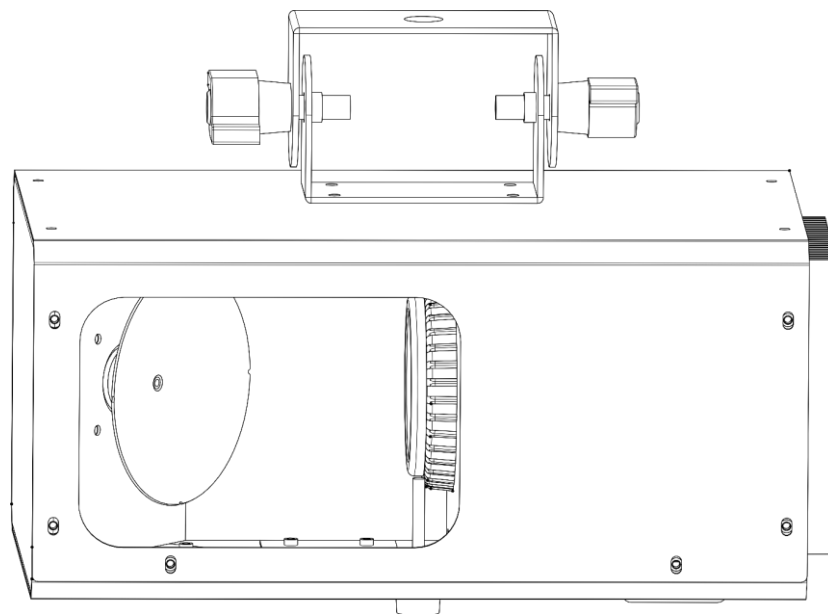

Fig. 01

Frontside

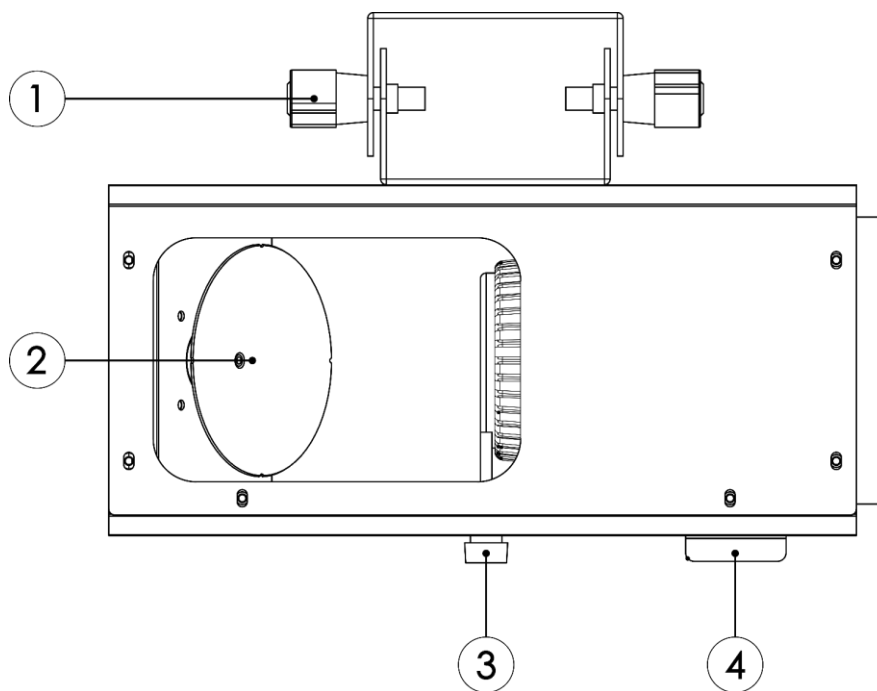

Fig. 02

- 01) Mounting bracket
- 02) Mirror

- 03) Height adjustment for floor installation
- 04) Gobo replacement screw

Backside

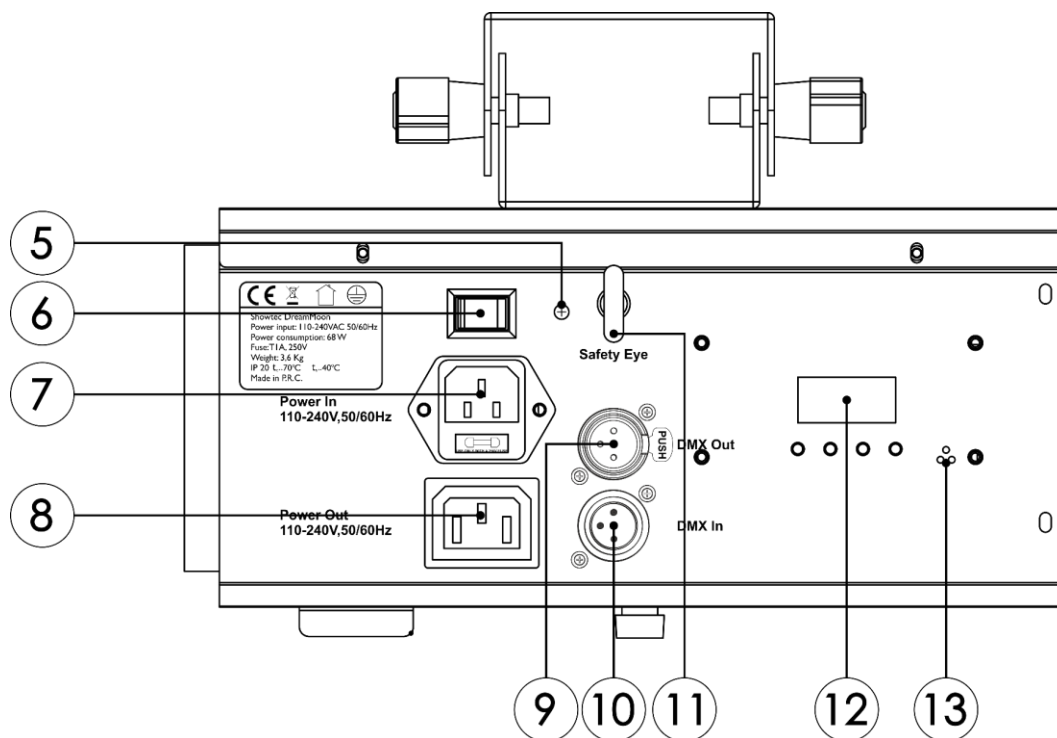

Fig. 03

- 05) Ground/earth connection
- 06) Power On/OFF
- 07) IEC power connector IN + Fuse T1 AL/250V
- 08) IEC power connector OUT
- 09) 3-pin DMX signal connector OUT

- 10) 3-pin DMX signal connector IN
- 11) Safety eye
- 12) LED display + control buttons
- 13) Built-in microphone

Installation

Remove all packing materials from the Dreammoon. Check if all foam and plastic padding is removed. Connect all cables.

Do not supply power before the whole system is set up and connected properly.

Always disconnect from electric mains power supply before cleaning or servicing.

Damages caused by non-observance are not subject to warranty.

Set Up and Operation

Follow the directions below, as they pertain to your preferred operation mode.

Before plugging the unit in, always make sure that the power supply matches the product specification voltage. Do not attempt to operate a 120V specification product on 230V power, or vice versa.

Connect the device to the main power supply.

Control Modes

There are 5 modes:

- Built-in programs (Show mode)
- Manual
- Sound-controlled
- Master/slave
- DMX-512 (5CH, 9CH)

One Dreammoon (Built-in programs, Manual)

- 01) Fasten the effect light to a firm trussing. Leave at least 0,5 meter on all sides for air circulation.
- 02) Always use a safety cable (ordercode 70140 / 70141).
- 03) Plug the end of the electric mains power cord into a proper electric power supply socket.
- 04) When the Dreammoon is not connected with a DMX cable, it functions as a stand-alone device. Please see pages 16 and 18 for more information about Built-in programs and Manual modes.

One Dreammoon (Sound-controlled)

- 01) Fasten the effect light to a firm trussing. Leave at least 0,5 meter on all sides for air circulation.
- 02) Always use a safety cable (ordercode 70140 / 70141).
- 03) Plug the end of the electric mains power cord into a proper electric power supply socket.
- 04) Turn on the music. If the device is set to sound-control, then the Dreammoon will react to the beat of the music. Please see page 16 for more information about the sound-control options.

Multiple Dreammoons (Master/Slave control)

- 01) Fasten the effect light onto firm trussing. Leave at least 0,5 meter on all sides for air circulation.
- 02) Always use a safety cable (ordercode 70140 / 70141).
- 03) Use a 3-p XLR cable to connect the Dreammoons and other devices.

The pins:



1. Earth
2. Signal (-)
3. Signal (+)

- 04) Link the units as shown in Fig. 04, connect a DMX signal cable from the first unit's DMX "out" socket to the second unit's "in" socket. Repeat this process to link the second and third units. You can use the same functions on the master device as described on pages 16 and 18 (Built-in programs, Manual). This means you can set your desired operation mode on the master device and all slave devices will react the same as the master device.

Multiple Dreammoons (Master/Slave control)

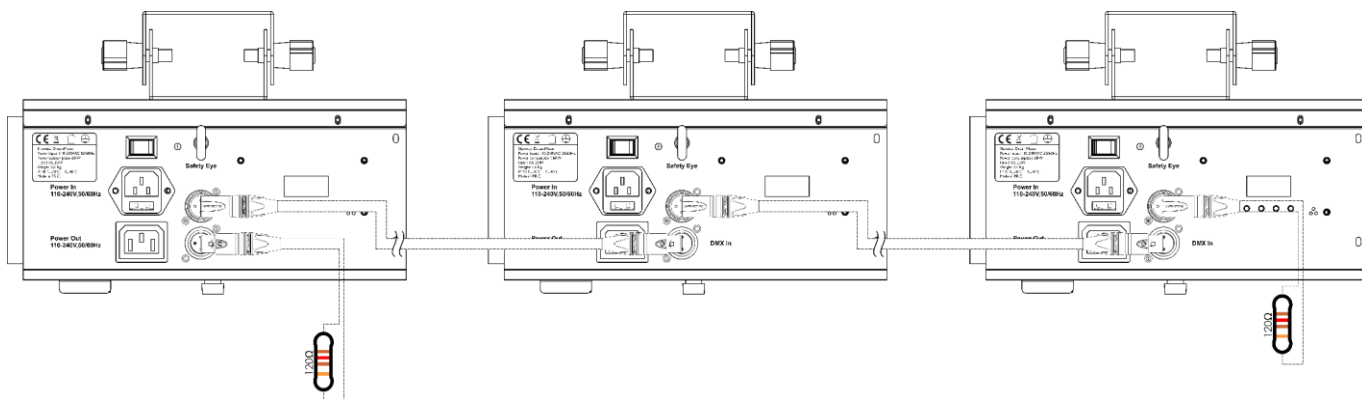
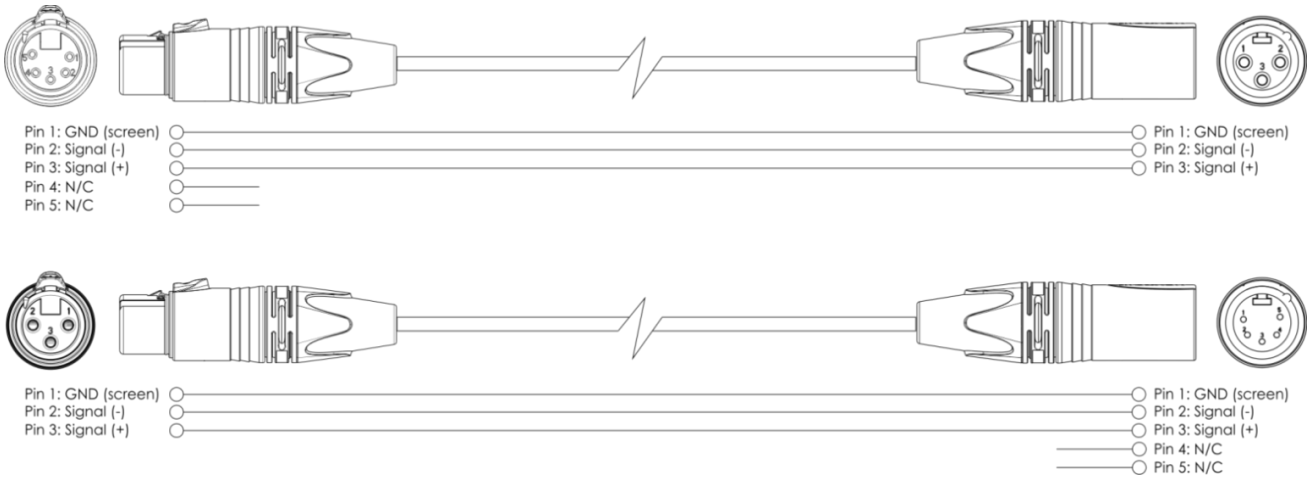

Fig. 04

Note: Link all cables before connecting electric power

Multiple Dreammoons (DMX Control)

- 01) Fasten the effect light to a firm trussing. Leave at least 0,5 meter on all sides for air circulation.
- 02) Always use a safety cable (ordercode 70140 / 70141).
- 03) Use a 3-pin XLR cable to connect the Dreammoons and other devices.



- 04) Link the units as shown in Fig. 05. Connect the first unit's DMX "out" socket with the second unit's "in" socket, using a DMX signal cable. Repeat this process to link the second and third units.
- 05) Supply electric power: Plug electric mains power cords into each unit's IEC socket, then plug the other end of the mains power cord into proper electric power supply sockets, starting with the first unit. Do not supply power before the whole system is set up and connected properly.

Multiple Dreammoons DMX Set Up

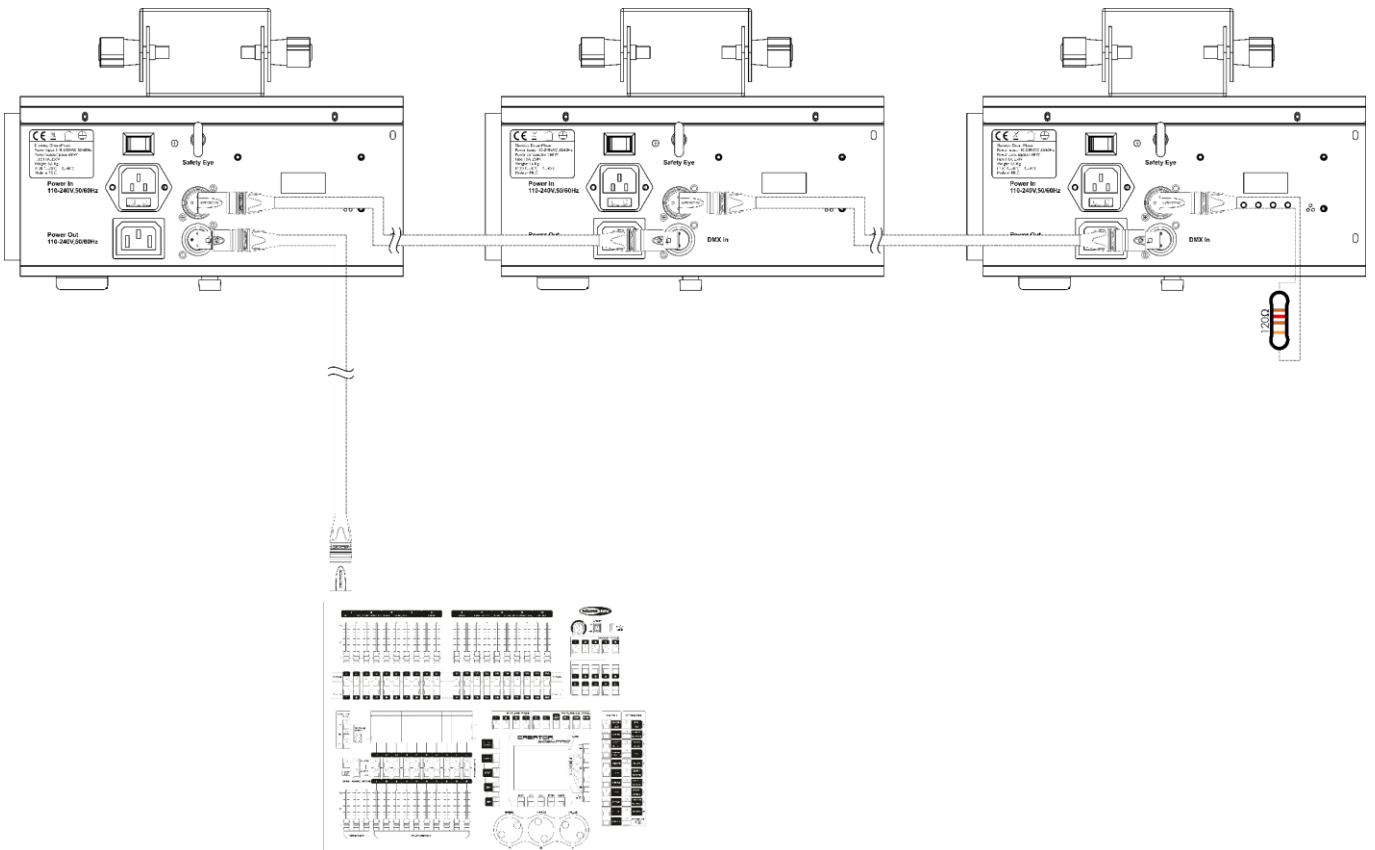

Fig. 05

Note: Link all cables before connecting electric power

Fixture Linking

You will need a serial data link to run light shows of one or more fixtures using a DMX-512 controller or to run synchronized shows of two or more fixtures set to a master/slave operating mode. The combined number of channels required by all the fixtures on a serial data link determines the number of fixtures the data link can support.

Important: Fixtures on a serial data link must be daisy-chained in a single line. To comply with the EIA-485 standard, no more than 30 devices should be connected on one data link. Connecting more than 30 fixtures on one serial data link without the use of a DMX optically isolated splitter may result in deterioration of the digital DMX signal.



Maximum recommended DMX data link distance: 100 meters

Maximum recommended number of fixtures on a DMX data link: 30 fixtures

Maximum recommended number of fixtures on a Power link: 25 units @120V

Maximum recommended number of fixtures on a Power link: 52 units @230V

Data Cabling

To link fixtures together, you must obtain data cables. You can purchase DAP Audio certified DMX cables directly from a dealer/distributor or construct your own cable. If you choose to create your own cable, please use data-grade cables that can carry a high quality signal and are less prone to electromagnetic interference.

DAP Audio DMX Data Cables

- DAP Audio Basic microphone cable for allround use. bal. XLR/M 3-pin > XLR/F 3-pin. **Ordercode** FL01150 (1,5 m), FL013 (3 m), FL016 (6 m), FL0110 (10 m), FL0115 (15 m), FL0120 (20 m).
- DAP Audio X-type data cable XLR/M 3-pin > XLR/F 3-pin. **Ordercode** FLX0175 (0,75 m), FLX01150 (1,5 m), FLX013 (3 m), FLX016 (6 m), FLX0110 (10 m).
- DAP Audio cable for the demanding user with exceptional audio-qualities and connector made by Neutrik®. **Ordercode** FL71150 (1,5 m), FL713 (3 m), FL716 (6 m), FL7110 (10 m).
- DAP Audio cable for the demanding user with exceptional audio-qualities and connector made by Neutrik®. **Ordercode** FL7275 (0,75 m), FL72150 (1,5 m), FL723 (3 m), FL726 (6 m), FL7210 (10 m).
- DAP Audio 110 Ohm cable with digital signal transmission. **Ordercode** FL0975 (0,75 m), FL09150 (1,5 m), FL093 (3 m), FL096 (6 m), FL0910 (10 m), FL0915 (15 m), FL0920 (20 m).
- DAP Audio DMX adapter: 3-pin/5-pin. **Ordercode** FLA30.

The Dreammoon can be operated with a controller in **control mode** or without the controller in **stand-alone mode**.

Control Panel

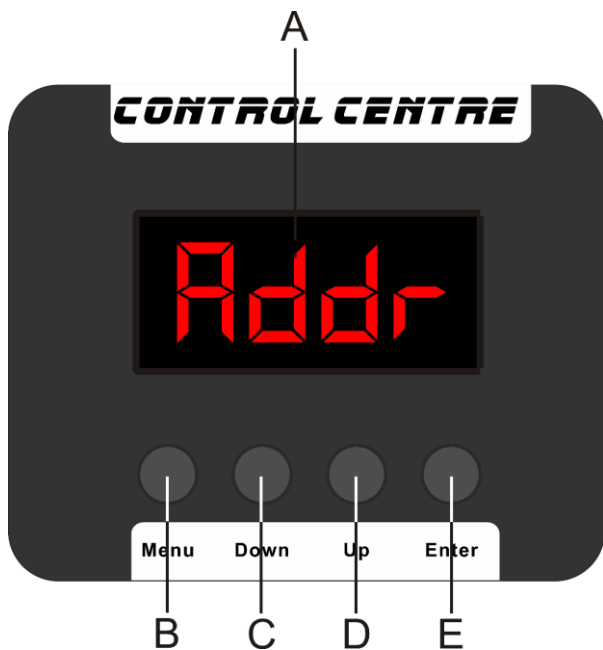

- A) LED display
- B) MENU button
- C) DOWN button
- D) UP button
- E) ENTER button

Fig. 06

Control Mode

The fixtures are individually addressed on a data-link and connected to the controller. The fixtures respond to the DMX signal from the controller. (When you select the DMX address and save it, the controller will display the saved DMX address, next time.)

DMX Addressing

The control panel on the backside of the device allows you to assign DMX fixture addresses, which is the first channel with which the Dreammoon will respond to the controller.

Please note, when you use the controller, the unit has **9** channels.

When using multiple Dreammoons, make sure you set the DMX addresses right.

Therefore, the DMX address of the first Dreammoon should be **1 (001)**; the DMX address of the second Dreammoon should be **1+9=10 (010)**; the DMX address of the third Dreammoon should be **10+9=19 (019)**, etc. Please, be sure that you do not have any overlapping channels in order to control each Dreammoon correctly. If two or more Dreammoons are addressed similarly, they will work similarly.

Controlling:

After having addressed all Dreammoon fixtures, you may now start operating these via your lighting controller.

Note: After switching on, the Dreammoon will automatically detect whether DMX 512 data is received or not. If there is no data received at the DMX-input, the "LED" on the control panel will not flash.

If not, the problem may be:

- The XLR cable from the controller is not connected with the input of the Dreammoon.
- The controller is switched off or defective, the cable or connector is defective, or the signal wires are swapped in the input connector.

Note: It is necessary to insert an XLR termination plug (with 120 Ohm) in the last fixture in order to ensure proper transmission on the DMX data link.

Menu Overview

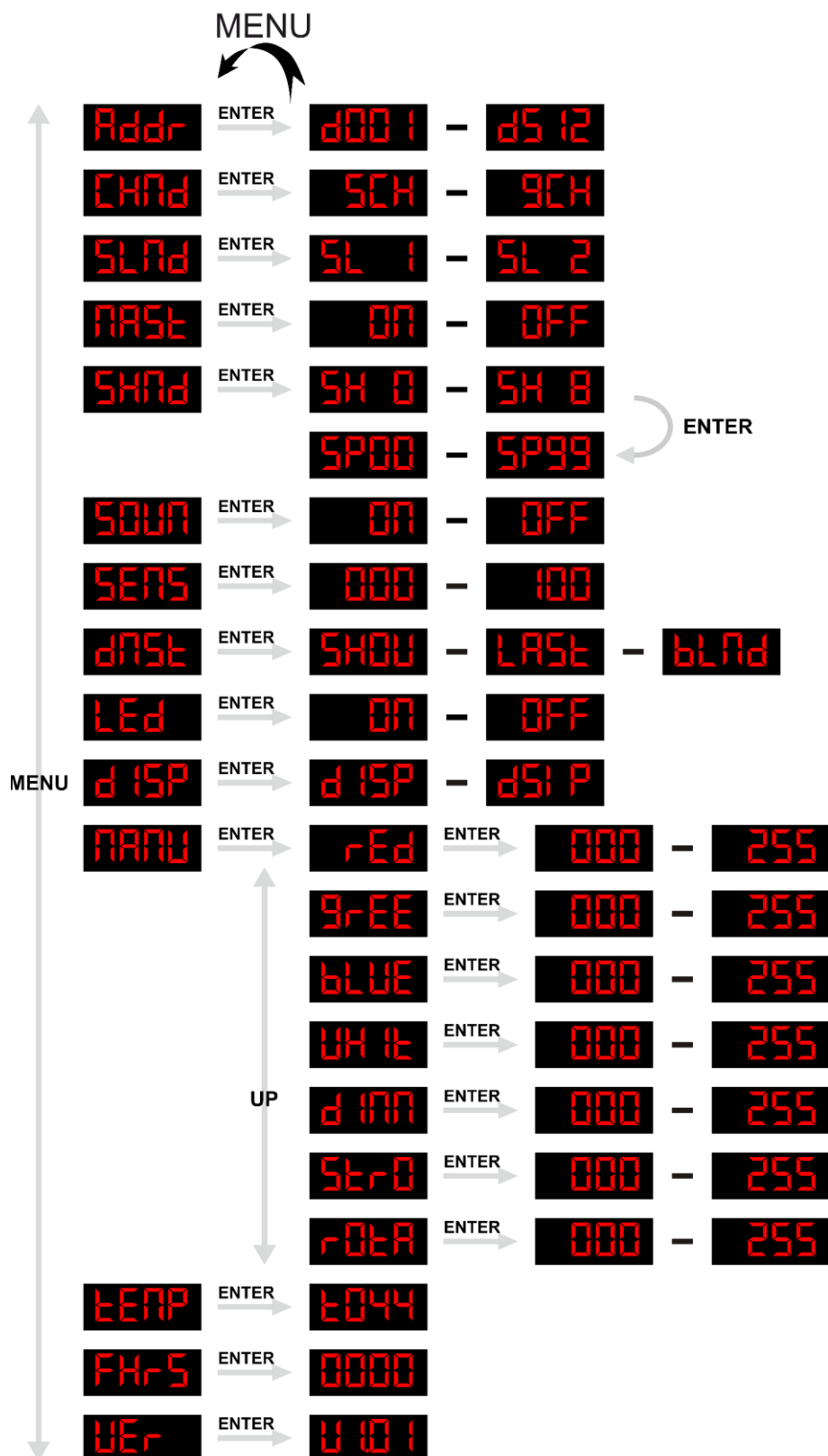

Main Menu Options

Addr	DMX address
CHNd	Channel mode
SLNd	Slave Mode
MASt	Master Mode
SHNd	Show Mode
SOUn	Sound-controlled
SEnS	Sensitivity
d75t	DMX Fail
LEd	Backlight
dISP	Display inverse
MANU	Manual Mode
TEMP	Temperature
FHrS	Runtime Fixture
VER	Software version

1. DMX Addressing

With this menu you can set the DMX address.

- 01) In main menu, press the **MENU** button until the display shows **Addr**.
- 02) Press the **ENTER** button to open this menu. You can choose 512 different DMX addresses.
- 03) Use the Up / Down buttons to select the required address from **0001** - **0512**.
- 04) Once you have set the desired DMX address, press the **ENTER** button to confirm your choice.

2. Channel Mode

With this menu you can set the Channel Mode.

- 01) In main menu, press the **MENU** button until the display shows **CHNd**.
- 02) Press the **UP/DOWN** buttons to choose one of the 2 following channel modes:

5CH	5-channel mode
9CH	9-channel mode

- 03) Press the **ENTER** button to confirm your choice.

3. Slave/Reverse Slave Mode

In this menu you can set the slave or slave reverse.

- 01) In main menu, press the **MENU** button until the display shows **SLNd**.
- 02) Press the **ENTER** button to open this menu.
- 03) Press the **UP/DOWN** buttons to choose one of the 2 slave modes:

SL 1 Normal slave mode

SL 2 Mirror slave mode

- 04) Press the **ENTER** button to confirm your choice.

4. Master/Slave Mode

With this menu you can set the Master or Slave Mode.

- 01) In main menu, press the **MENU** button until the display shows **MASt**.
- 02) Press the **ENTER** button to open this menu.
- 03) Press the **UP/DOWN** buttons to choose one of the 2 options:

ON Master Mode

OFF Slave Mode (All slave devices will react the same as the master device)

- 04) Press the **ENTER** button to confirm your choice.

5. Show Mode

- 01) In main menu, press the **MENU** button until the display shows **SHNd**.
- 02) Press the **ENTER** button to open this menu.
- 03) Use the UP/DOWN buttons to toggle between the auto programs:

SH 0 - **SH 8** Auto Program 0 - 8

- 04) Press the **ENTER** button to confirm your choice.
- 05) If you have chosen one of the auto programs **SH 0** - **SH 8**, press the **ENTER** button to open the following menu.
- 06) Press the **UP/DOWN** buttons to set the program speed. The adjustment range is between **SP00** ^{Up/Down} **SP99**, from slow to fast.
- 07) Press the **ENTER** button to confirm your choice.

6. Sound control Mode

With this menu you can set the Sound control.

- 01) In main menu, press the **MENU** button until the display shows **SOUN**.
- 02) Press the **ENTER** button to open this menu.
- 03) Press the **UP/DOWN** buttons to choose one of the 2 options:

ON Sound control ON, the device will react to the beat of the music

OFF Sound control OFF. If the device has been set to Off, the device will not react to the beat of the music.

- 04) Press the **ENTER** button to confirm your choice.

7. Sensitivity Mode

With this menu you can set the Sensitivity control.

- 01) Press the **MENU** button and then the Up / Down buttons, until the display shows **SENS**.
- 02) Press the **ENTER** button to open this menu.
- 03) You can choose 100 different Audio Sensitivity levels **000** - **100**.
- 04) Press the **ENTER** button to confirm your choice.

8. Blackout/DMX Fail Mode

With this menu you can set the device's behavior in case of a DMX signal error.

- 01) Press the **MENU** button and then the Up / Down buttons, until the display shows **d75t**.
- 02) Press the **ENTER** button to open this menu.
- 03) Press the **UP/DOWN** buttons to select one of the 3 options:
 - **SHOU**: If the DMX signal is lost, the device will not blackout, it will automatically start its selected program **SH 0** - **SH 8**.
 - **LAST**: If the DMX signal is lost, the device will not blackout, it will use its last properly received DMX signal, ensuring uninterrupted performance.
 - **BLND** OFF: If the DMX signal is lost, the device will black out the light output. Do not use this option when the device is used as a stand-alone device (i.e. without a DMX signal and without an XLR cable). The moving head will remain in a blackout state, no matter what setting you have set in one of the stand-alone modes.

9. Backlight

With this menu you can set the backlight of the display.

- 01) Press the **MENU** button until the display shows **LEd**.
- 02) Press the **ENTER** button to open this menu.
- 03) If you choose "**OFF**", the display will blackout after 15 seconds.
- 04) If you choose "**ON**", the display will always light up, even if there is no operation at the device.
- 05) Press the **MENU** button to go back to the previous step.

10. Display settings

- 01) Press the **MENU** button and then the Up / Down buttons, until the display shows **d15P**.
- 02) Press the **ENTER** button to open this menu.
- 03) Press the **UP** and **DOWN** buttons to toggle between:
 - d15P** Normal Display
 - d51P** Display Invert
- 04) Press the **ENTER** button to confirm your choice.

11. Manual

With this menu you can manually set the desired colors.

- 01) Press the **MENU** button until the display shows **MANU**.
- 02) Press the **ENTER** button to open the menu.
- 03) Press the **ENTER** button to toggle through the available options:



Gradual adjustment red intensity(0-255)



Gradual adjustment green intensity (0-255)



Gradual adjustment blue intensity (0-255)



Gradual adjustment white intensity (0-255)



Master Dimmer intensity, from dark to brightest (0-255)



Strobe speed from slow to fast



Rotation speed from slow to fast

- 04) Press the **UP/DOWN** buttons to change the values.
- 05) Press the **ENTER** button to save changes/proceed.

12. Temperature

With this option you can see if the temperature of the device.

- 01) Press the **Up/Down** buttons until the display shows **TEMP**.
- 02) Press the **ENTER** button to see the current LED temperature.

13. Lifetime

With this menu you can view how long your Dreammoon has been used.

- 01) Press the **MENU** button and then the Up / Down buttons, until the display shows **FHrS**.
- 02) Press the **ENTER** button to open this menu.
- 03) The Dreammoon will now show its operating time.

14. Firmware Version

With this menu you can view which version your Dreammoon has.

- 01) Press the **MENU** button and then the Up / Down buttons, until the display shows **VER**.
- 02) Press the **ENTER** button to open this menu.
- 03) The Dreammoon will now show its currently installed software version **V1.01**.

DMX Channels

5 channels

Channel 1 – Red

0-255 Gradual adjustment Red, from 0-100%

Channel 2 – Green

0-255 Gradual adjustment Green, from 0-100%

Channel 3 – Blue

0-255 Gradual adjustment Blue, from 0-100%

Channel 4 – White

0-255 Gradual adjustment White, from 0-100%

Channel 5 – Lens Rotation Wheel (⚠ CH1-4 must be set between 1-255 ⚠)

0-127 Indexing

128-191 CW rotation, from fast to slow

192-255 CCW rotation, from slow to fast

9 channels

Channel 1 – Red ⚠ CH5 must be open ⚠

0-255 Gradual adjustment Red, from 0-100%

Channel 2 – Green ⚠ CH5 must be open ⚠

0-255 Gradual adjustment Green, from 0-100%

Channel 3 – Blue ⚠ CH5 must be open ⚠

0-255 Gradual adjustment Blue, from 0-100%

Channel 4 – White ⚠ CH5 must be open ⚠

0-255 Gradual adjustment White, from 0-100%

Channel 5 – Master Dimmer

0-255 Gradual adjustment from dark to brightest 0-100%

Channel 6 – Strobe

0-63 Open

64-95 Strobe frequency, from low to high frequency

96-127 Open

128-159 Strobe frequency, from fast out to slow in, from low to high frequency

160-191 Open

192-223 Random strobe frequency, from low to high frequency

224-255 Open

Channel 7 – Built-in programs

0-3 Not functional

4-31 Program 0 (Program can be sound-activated if SOUN has been set to ON)

32-59 Program 1 (Program can be sound-activated if SOUN has been set to ON)

60-87 Program 2 (Program can be sound-activated if SOUN has been set to ON)

88-115 Program 3 (Program can be sound-activated if SOUN has been set to ON)

116-143 Program 4 (Program can be sound-activated if SOUN has been set to ON)

144-171 Program 5 (Program can be sound-activated if SOUN has been set to ON)

172-199 Program 6 (Program can be sound-activated if SOUN has been set to ON)

200-227	Program 7 (Program can be sound-activated if SOUN has been set to ON)
228-255	Program 8 (Program can be sound-activated if SOUN has been set to ON)

Channel 8 – Program Speed (⚠ CH7 must be set between 1-255 ⚠)

0-255	From slow to fast
-------	-------------------

Channel 9 – Lens rotation wheel (⚠ CH1-4 and CH5 must be set between 1-255 ⚠)

0-127	Lens indexing
128-191	CCW rotation, from fast to slow
192-255	CW rotation, from slow to fast

Maintenance

The Dreammoon requires almost no maintenance. However, you should keep the unit clean. Otherwise, the fixture's light output will be significantly reduced. Disconnect the mains power supply, and then wipe the cover with a damp cloth. Do not immerse in liquid. Wipe lens clean with glass cleaner and a soft cloth. Do not use alcohol or solvents.

The front lens will require weekly cleaning, as smoke-fluid tends to build up residues, reducing the light output very quickly.

Keep connections clean. Disconnect electric power, and then wipe the DMX and audio connections with a damp cloth. Make sure connections are thoroughly dry before linking equipment or supplying electric power.

The operator has to make sure that safety-related and machine-technical installations are to be inspected by an expert after every year in the course of an acceptance test.

The operator has to make sure that safety-related and machine-technical installations are to be inspected by a skilled person once a year.

The following points have to be considered during the inspection:

- 01) All screws used for installing the device or parts of the device have to be tightly connected and must not be corroded.
- 02) There may not be any deformations on housings, fixations and installation spots.
- 03) Mechanically moving parts like axles, eyes and others may not show any traces of wearing.
- 04) The electric power supply cables must not show any damages or material fatigue.

Replacing the Fuse

Power surges, short-circuit or inappropriate electrical power supply may cause a fuse to burn out. If the fuse burns out, the product will not function whatsoever. If this happens, follow the directions below:

- 01) Unplug the unit from electric power source.
- 02) Insert a flat-headed screwdriver into a slot in the fuse cover. Gently pry up the fuse cover. the fuse will come out.
- 03) Remove the used fuse. If brown or unclear, it is burned out.
- 04) Insert the replacement fuse into the holder. Reinsert the fuse cover. Be sure to use a fuse of the same type and specification. See the product specification label for details.

Replacing the Gobo

- 01) Unplug the unit from electric power source.
- 02) Loosen the gobo compartment cover screw and remove the cover.

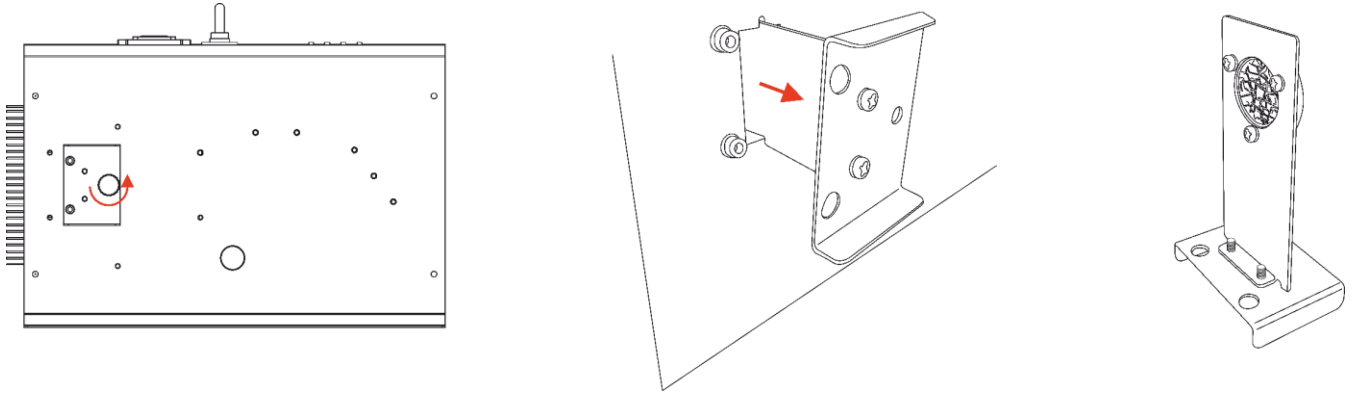

Fig. 07

- 03) Remove the fixing spring.
- 04) Insert the new gobo.



Fig. 08

- 05) Fixate the gobo with the spring.

Troubleshooting

This troubleshooting guide is meant to help solve simple problems.

If a problem occurs, carry out the steps below in sequence until a solution is found. Once the unit operates properly, do not carry out following steps.

No Light

If the light effect does not operate properly, refer servicing to a technician.

Suspect three potential problem areas as: the power supply, the LEDs, the fuse.

- 01) Power supply. Check that the unit is plugged into an appropriate power supply.
- 02) The LEDs. Return the Dreammoon to your Showtec dealer.
- 03) The fuse. Replace the fuse. See page 20 for replacing the fuse.
- 04) If all of the above appears to be O.K., plug the unit in again.
- 05) If you are unable to determine the cause of the problem, do not open the Dreammoon, as this may damage the unit and the warranty will become void.
- 06) Return the device to your Showtec dealer.

No Response to DMX

Suspect the DMX cable or connectors, a controller malfunction, a light effect DMX card malfunction.

- 01) Check the DMX setting. Make sure that DMX addresses are correct.
- 02) Check the DMX cable: Unplug the unit; change the DMX cable; then reconnect to electrical power. Try your DMX control again.
- 03) Determine whether the controller or light effect is at fault. Does the controller operate properly with other DMX products? If not, take the controller in for repair. If so, take the DMX cable and the light effect to a qualified technician.

Problem	Probable cause(s)	Solution
One or more fixtures do not function at all	No power to the fixture	<ul style="list-style-type: none"> • Check if power is switched on and cables are plugged in
	Primary fuse blown.	<ul style="list-style-type: none"> • Replace fuse
Fixtures reset correctly, but all respond erratically or not at all to the controller	The controller is not connected.	<ul style="list-style-type: none"> • Connect controller
	3-pin XLR Out of the controller does not match XLR Out of the first fixture on the link (i.e. signal is reversed)	<ul style="list-style-type: none"> • Install a phase reversing cable between the controller and the first fixture on the link
Fixtures reset correctly, but some respond erratically or not at all to the controller	Poor data quality	<ul style="list-style-type: none"> • Check data quality. If much lower than 100 percent, the problem may be a bad data link connection, poor quality or broken cables, missing termination plug, or a defective fixture disturbing the link
	Bad data link connection	<ul style="list-style-type: none"> • Inspect connections and cables. Correct poor connections. Repair or replace damaged cables
	Data link not terminated with 120 Ohm termination plug	<ul style="list-style-type: none"> • Insert termination plug in output jack of the last fixture on the link
	Incorrect addressing of the fixtures	<ul style="list-style-type: none"> • Check address setting
	One of the fixtures is defective and disturbs data transmission on the link	<ul style="list-style-type: none"> • Bypass one fixture at a time until normal operation is restored: unplug both connectors and connect them directly together. • Have the defective fixture serviced by a qualified technician
	3-pin XLR Out on the fixtures does not match (pins 2 and 3 reversed)	<ul style="list-style-type: none"> • Install a phase-reversing cable between the fixtures or swap pin 2 and 3 in the fixture that behaves erratically
Shutter closes suddenly	The laser diode has lost its index position and the fixture is resetting the effect	<ul style="list-style-type: none"> • Contact a technician for servicing the problem persists
No light or LEDs or laser cuts out intermittently	Fixture is too hot	<ul style="list-style-type: none"> • Allow the fixture to cool down • Clean the fan • Make sure air vents and the front lens are not blocked • Turn up the air conditioning
	LEDs or laser damaged	<ul style="list-style-type: none"> • Disconnect the fixture and return it to your dealer
	The power supply settings do not match local AC voltage and frequency	<ul style="list-style-type: none"> • Disconnect fixture. Check settings and correct if necessary

Product Specifications

Model:	Showtec Dreammoon
Input voltage:	100-240V AC, 50/60Hz
Power consumption:	68W (full output)
DMX linking:	30 pcs
Power linking @110V	25 pcs
Power linking @240V	52 pcs
Fuse:	T1AL/250V
Dimensions:	275 x 200 x 191 mm (LxWxH)
Weight:	3,6 kg
Operating and Programming:	
Signal pin OUT:	Pin 1 (earth), pin 2 (-), pin 3 (+)
DMX Mode:	5, 9 channels
Signal input:	3-pin DMX IN
Signal output:	3-pin DMX OUT
Electro-mechanical effects:	
Housing:	Die-cast black aluminum
DMX-control:	via standard DMX-controller
On Board:	4-digit LED display for easy setup
Control:	Built-in programs, Manual, Sound-controlled, Master/Slave, DMX
Connections:	IEC connectors IN/OUT, 3-pin XLR IN/OUT
Cooling:	Convection
IP rating:	IP20
LED Beams:	1x 60W RGBW 4-in-1 LEDs
Max. ambient temperature t_a :	35°C
Max. housing temperature t_B :	80°C
Minimum distance:	
Minimum distance from flammable surfaces:	0,5 m
Minimum distance to lighted object:	1 m

Design and product specifications are subject to change without prior notice.



Website: www.Showtec.info
 Email: service@highlite.com

Dimensions

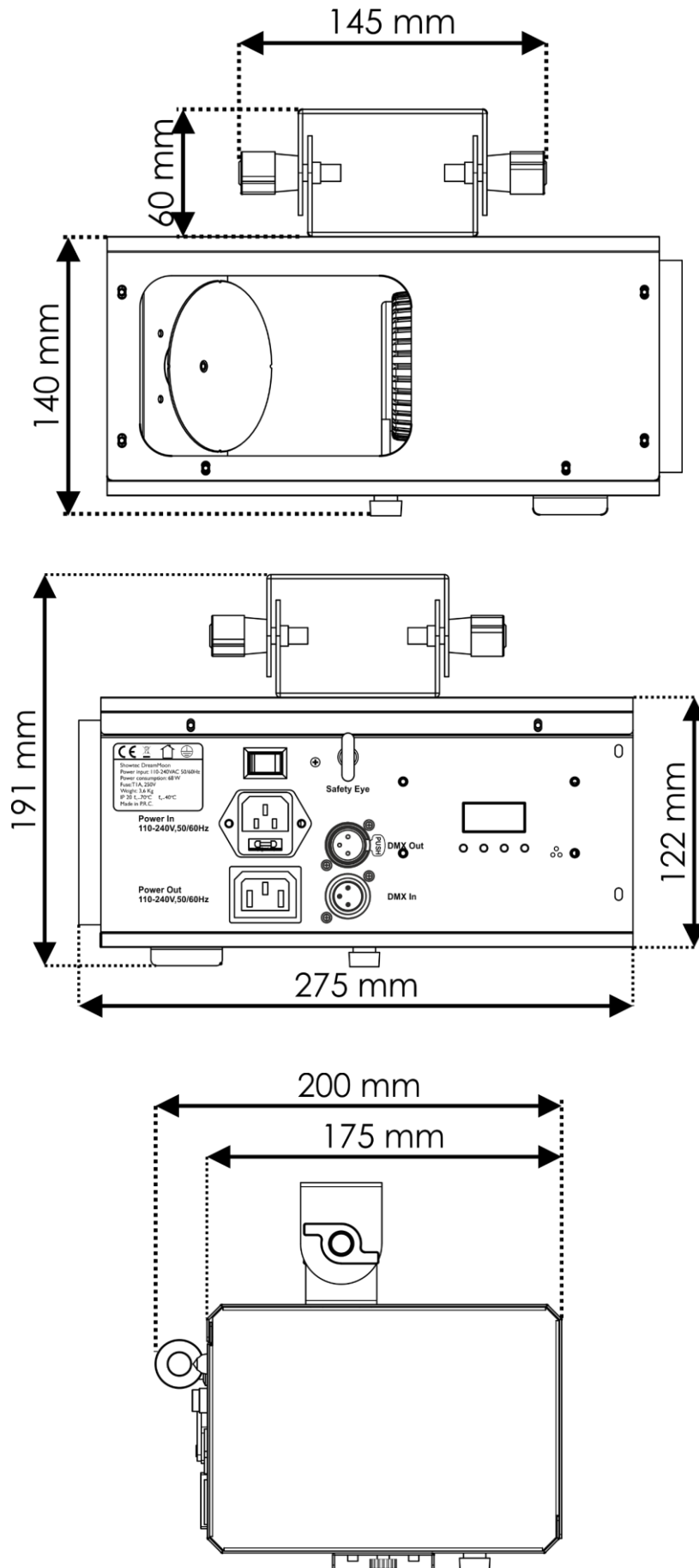

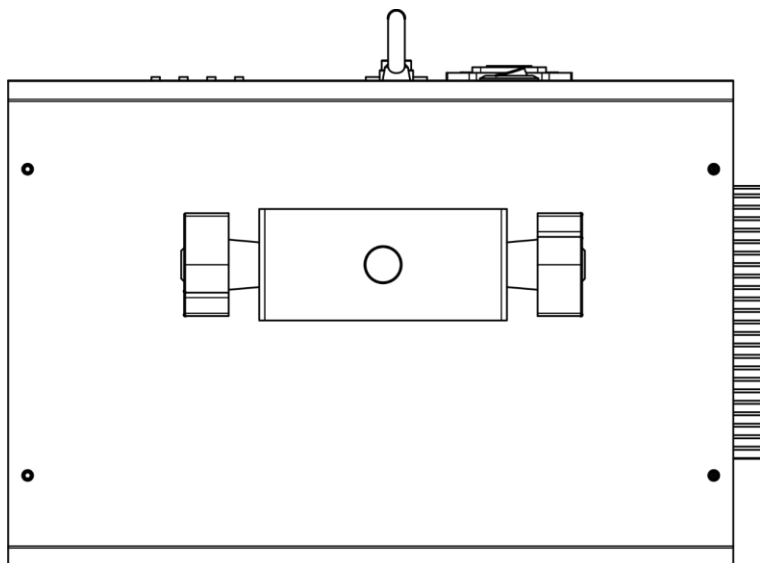
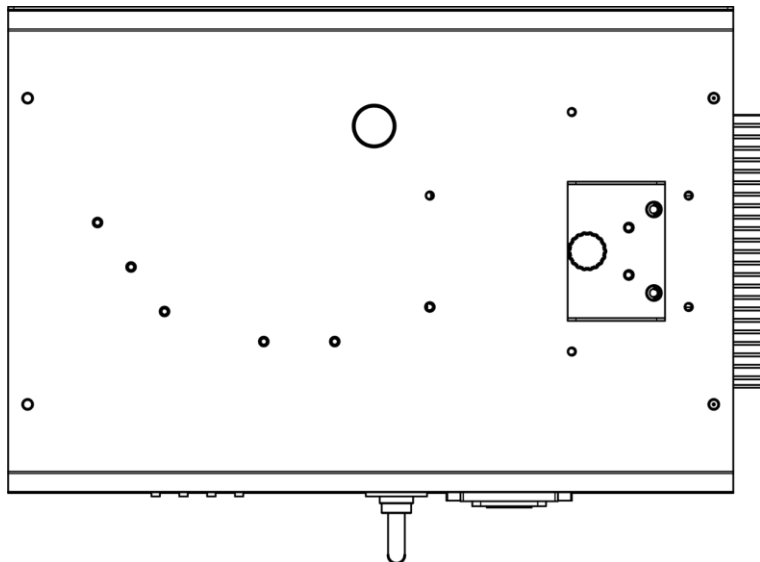
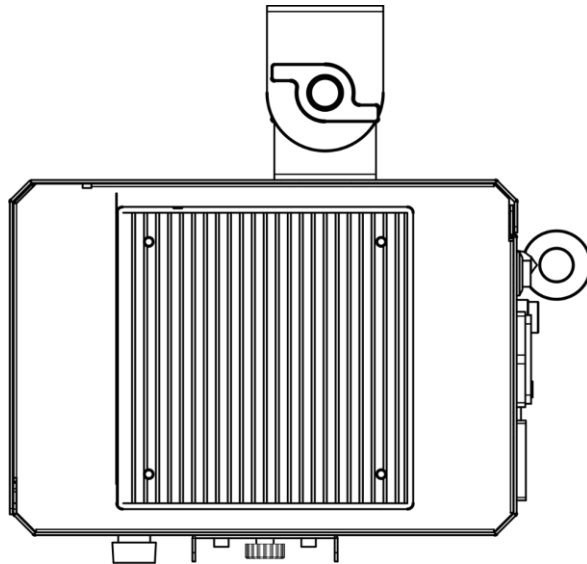



©2019 Showtec