

Data sheet
AT-201



Arc-Series

Architectural Sound Design.





Description

This versatile, well-designed two-way speakersystem includes a powerful 10" cone speaker and a high-quality 1" driver. The big CD horn can be rotated 90°. The speakers are time-aligned and guarantee phase-optimized sound dispersion. A crossover with electronic high-frequency protection circuit is also integrated. The multiply birch wood housing is reinforced on the inside with steel brackets. 9x M8 and 2x M6 threaded inserts guarantee safe speaker and bracket installation in accordance with all current regulations. The AT-201 can be combined with subwoofers AS-20/ASP-20, AS-30/ASP-30 and AS-40.

Optional versions

Optional special weatherproof plastic coating.
Optional 100 volts version. All RAL colours

Technical specifications

electro-acoustical features

acoustic design	passive loudspeaker, 2-way, bass reflex
components ^[1]	10" / 1" on rotatable CD-horn, with self-resetting IPC ^[1] -HF protection
power rating (nominal) ^[1]	300 W
power rating (program) ^[2]	600 W
power rating (peak) ^[3]	1200 W
sensitivity ^[4]	97 dB
maximum SPL ^[3]	127 dB
frequency range ^[5]	55 Hz – 20 kHz
nominal dispersion (h x v) ^[6]	90° x 60° or 60° x 40°
nominal impedance	8 ohms

The manufacturer reserves the right to make technical modifications according to legal regulations stipulating the continual improvement of product features.

^[1] according to IEC-60268-5 long term

^[2] according to IEC-60268-5 short term

^[3] Peak, 20 ms with bandpass filtered pink noise signal according to IEC 60268-2 at one octave above the lower limit of the frequency range

^[4] 2,83 V at 8 ohms (2 V at 4 ohms, 4 V at 16 ohms) at a distance of 1 meter under anechoic fullspace conditions

The Fohhn® AT-201 is both a sound and flexibility specialist. Extremely effective with compact dimensions, it can be used as a main sound system in locations with a complex architectural layout to replace large speakers.

Applications

Conference and training rooms, clubs, sport and multifunctional halls, theatres, musicals, theme parks, discos, small stadiums and similar venues.

Connections

8-way Phoenix terminal strip, two adjacent pins are always connected in parallel to loop through another speaker system. The connector is included in the delivery.

LowZ version (low impedance)



100 volts version with pickups

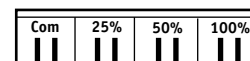

features

enclosure	birch plywood cabinet, metal strengthened
protection grille	ball impact resistant metal, powder coated finish
rigging points	9x M8 and 2x M6 thread
connections	8-pole Phoenix connector
standard colours	textured finish black or white
frontal design	acoustic foam, same colour as enclosure
dimensions (W x H x D)	330 x 510 x 300 mm
weight ^[7]	14,5 kg

optional features

integrated 100 V-transformer	60/30/15 W, 120/60/30 W oder 240/120/60 W
optional colours	all RAL-colours
weather protection	scratch-proof plastic coating, impregnated speaker membranes

CAAD simulation data

EASE

^[5] -10 dB under anechoic halfspace-conditions

^[6] horizontal x vertical at -6 dB, rotatable horn

^[7] net weight without optional equipment

^[1] Intelligent Protection Circuit. Voltage-controlled semiconductor circuit protecting the HF-driver against overload highly effective and with very short attack time.

Fig. 1/2/3/4: Horn 90° x 60°

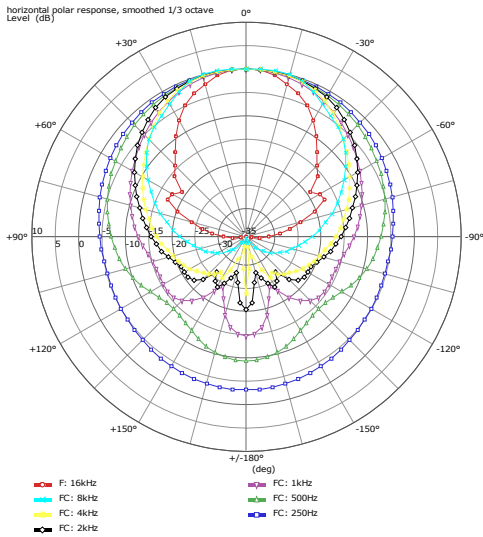

Fig. 1: Horizontal polar pattern

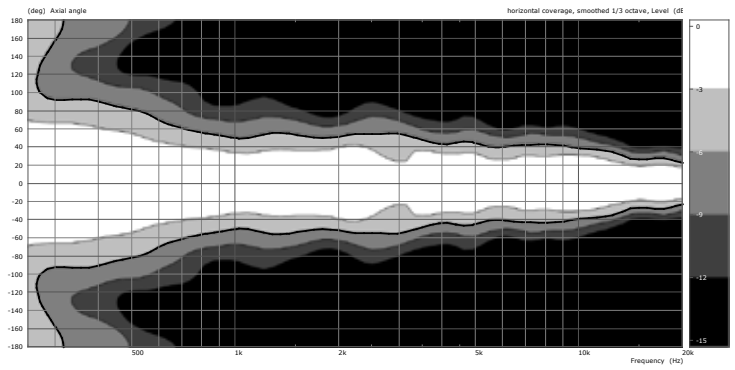

Fig. 2: Horizontal coverage

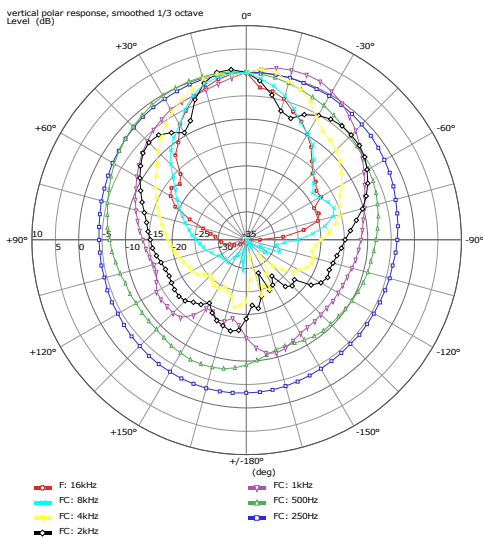

Fig. 3: Vertical polar pattern

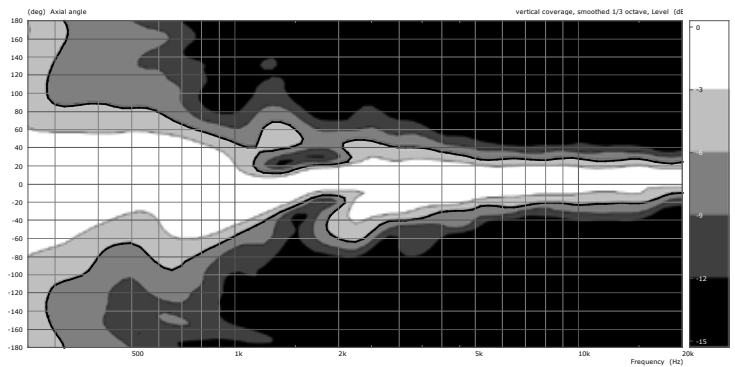

Fig. 4: Vertical coverage

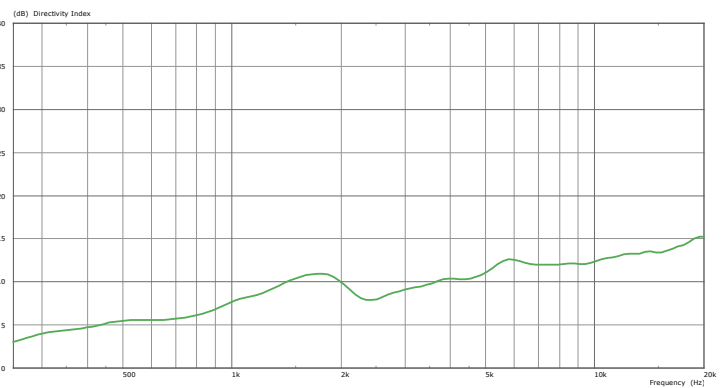

Fig. 5: Directivity index

Fig. 1/2/3/4: Horn 60° x 40°

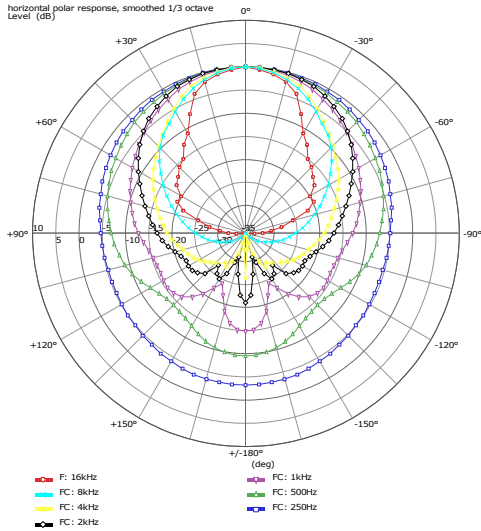

Fig. 1: Horizontal polar pattern

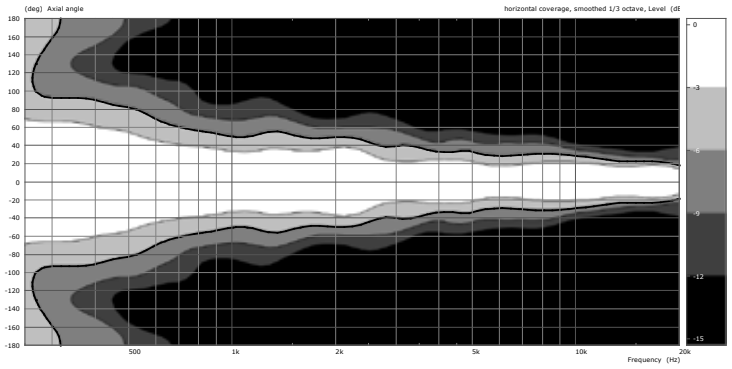

Fig. 2: Horizontal coverage

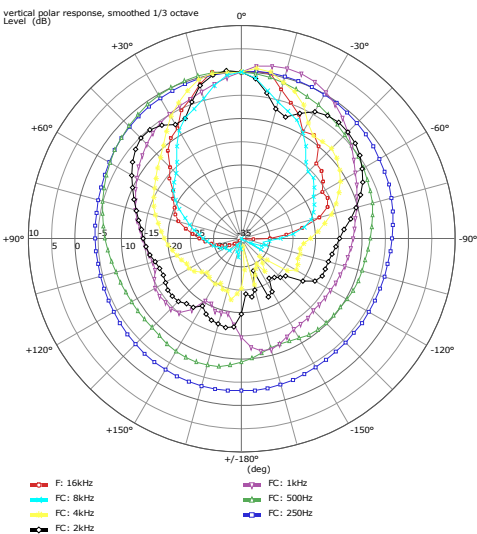

Fig. 3: Vertical polar pattern

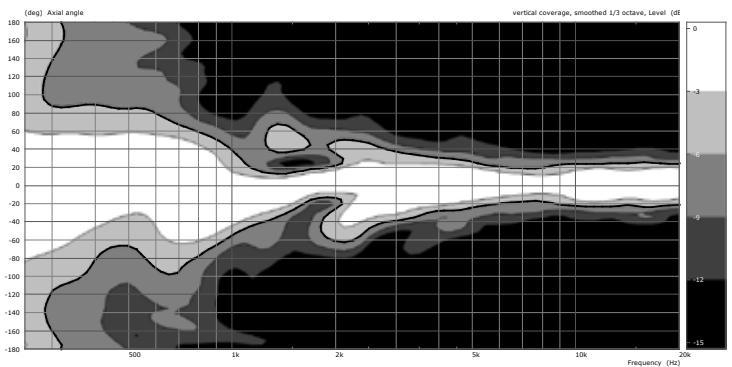

Fig. 4: Vertical coverage

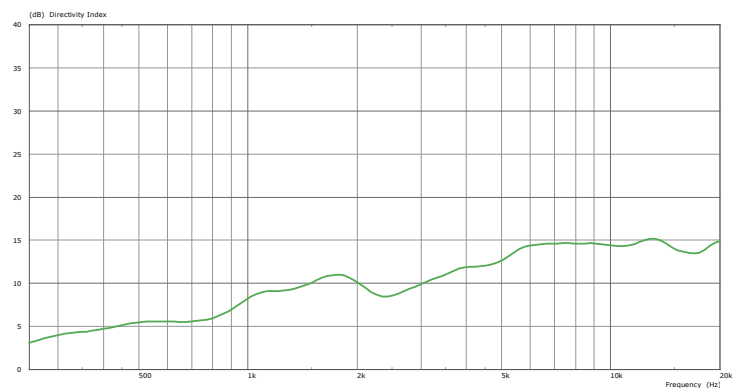

Fig. 5: Directivity index

Fig. 6: Frequency response

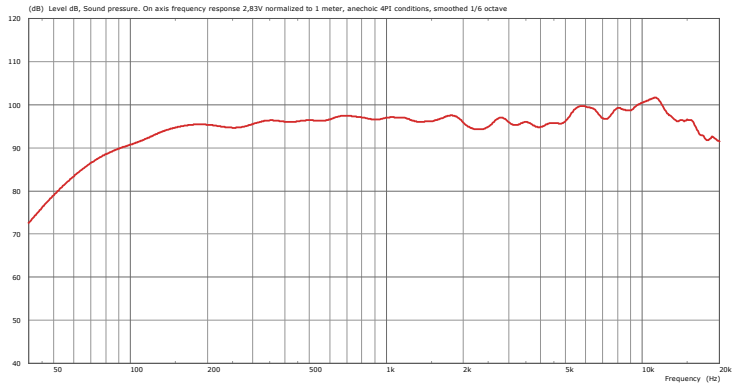

Fig. 7: Impedance

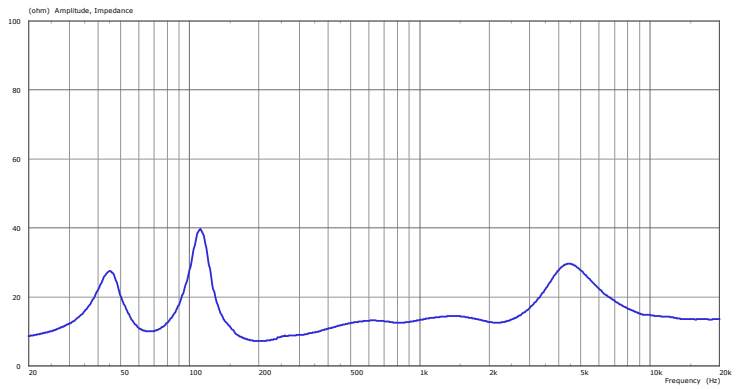
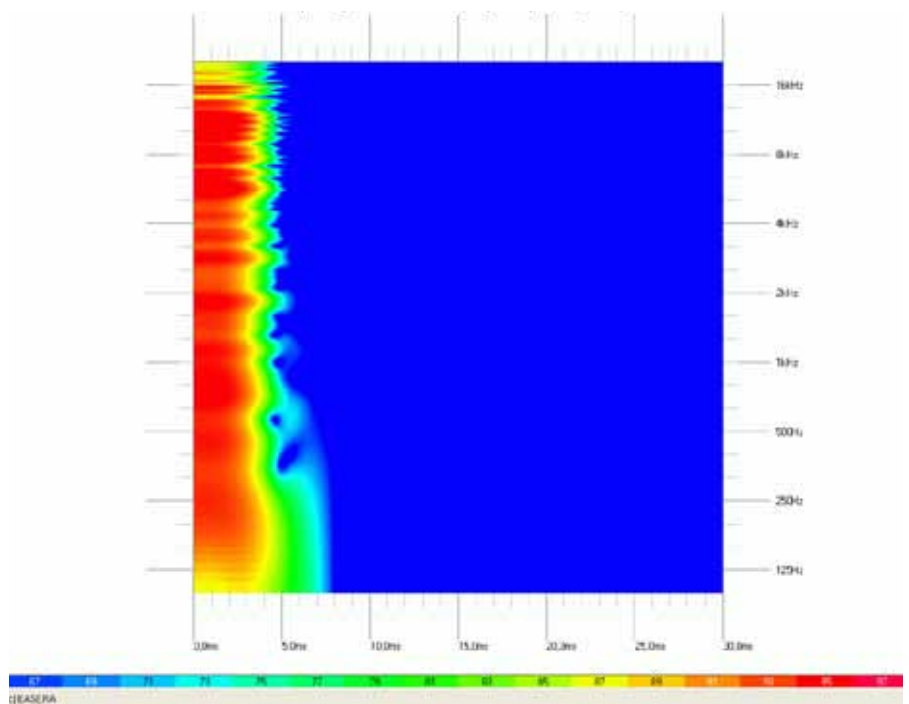

Fig. 8: Spectral decay



Controlling Arc-Series speakers

1. Fohhn system DSP amplifiers

Fohhn offers a range of specially adapted system DSP amplifiers for controlling Arc speaker systems, which guarantee maximum sound performance and operational reliability for your Fohhn products. As manufacturers of speaker, amplifier and DSP technology, we know our systems inside and out right down to the smallest detail and are therefore in a perfect position to provide our users with the best overall system.

Fohhn System DSP amplifier are offering following advantages:

Integrated high-performance DSP technology:

- quick set-up,
- minimal space requirements in electronics cabinet,
- minimal cable requirements,
- fewer cable faults,
- controller and amplifier can be controlled and monitored using the same software.

Dual DSP technology

The DSP amplifiers contain 2 separate DSP engines with enormous capacity and processing power for 5 digital audio devices (DSP-1) and Fohhn specific speaker databases (DSP-2).

Remote monitoring and control

Integrated temperature and operating time monitor, status indicator / protection, remote control capability / network compatibility using a laptop, wall installation modules or media control systems.

Fohhn® dual DSP technology

DSP-1: Integrated digital audio devices

Each amplifier channel has a:

- programmable 10 band parametric EQ,
- compressor/limiter/noise gate,
- delay,
- X-over function,
- top-quality pink noise and sweeptone generator

DSP-2: Speaker management

An integrated speaker database guarantees excellent sound quality and protection for all Fohhn speaker types. A sophisticated algorithm developed by Fohhn engineers and adapted to each speaker allows the individual monitoring and adjustment of bass, mid and high ranges.

1.1 Amplifier recommendations for the Arc-Series



D-2.750

2 channel operation, 2x 750 W / 4 ohms,
2x 390 W / 8 ohms

Fohhn Audio DSP, display, remote control

D-4.750

4+2 channel operation, 4x 750 W / 4 ohms,
4x 390 W / 8 ohms

2x DSP line out channels for controlling a conventional amplifier

Fohhn Audio DSP, display, remote control

	Arc-Tops										Linea		Arc-Subs											
	AT-05	AT-06	AT-07	AT-08	AT-09	AT-10	AT-201	AT-22w	AT-30	AT-35	AT-40	AT-50	AT-66	AL-10-150	LX-100/150	AS-10	ASP-10	AS-20	ASP-20	AS-30	ASP-30	AS-40	ASP-40	
D-2.750	x	x	x	x	x	x	x	x	x					x	x	x	x	x	x					
D-4.750	x	x	x	x	x	x	x	x	x					x	x	x	x	x	x					
D-2.1500									x	x	x	x	x							x	x	x	x	
D-4.1200									x	x	x	x	x							x	x	x	x	

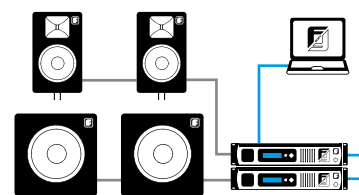

2x Sub passive / 2x Top passive
2x DSP amplifier

Controlling Arc-Series speakers

2. Standard amplifiers combined with Fohhn controllers

Standard amplifiers / 100V amplifiers / multichannel amplifiers combined with Fohhn FC-9 DSP system controllers

All of the speaker systems in the Fohhn Arc-Series can be operated in combination with standard amplifiers (e.g. Bittner amplifiers). Each Fohhn speaker model has a linear design, neutral sound adaptation function and is fitted with an integrated crossover with electronic tweeter protection.

We recommend integrating the FC-9 Fohhn DSP system controller for applications involving standard multichannel amplifiers, 100V amplifiers or monitored amplifiers according to EN 60849.

The FC-9 guarantees maximum sound quality, operational reliability and performance features that no other standard controller can offer in combination with our Fohhn speakers.

Sound quality. Reliability. Intelligent control.

- * Fohhn DSPs guarantee maximum sound performance
- * 5 premium audio tools such as Parametric EQ are integrated
- * Integral speaker and amplifier database for maximum operating reliability
- * Remote monitoring/operation, network-compatible
- * Automatic amplifier calibration function CAS
- * 8 input switching contacts for easy system integration
- * Perfect adaptation to all standard amplifiers

FC-9 DSP system controller



DIN EN 60849 (VDE 0828)

Bittner amplifiers



BITTNER
AUDIO

In addition to our special Fohhn® DSP amplifiers, we also offer the complete range of amplifiers manufactured by Bittner Audio for low-ohm or 100 volt applications. Bittner Audio offers solutions such as multichannel amplifiers with eight standard channels and important features for integration in electroacoustic emergency warning systems according to DIN EN 60849 (VDE 0828). Contact us for more information!

Advantages of the FC-9 controller:

Perfect adaptation to all standard amplifiers

Automatic amplifier calibration function and integrated amplifier database for perfect adaptation.

Dual DSP technology

The FC-9 contains 2 separate DSP engines with enormous capacity and processing power for Fohhn specific speaker databases and 5 digital audio devices.

Integrated speaker database

Guarantees excellent sound quality and protection for all Fohhn speaker types.

A sophisticated algorithm developed by Fohhn engineers and adapted to each speaker allows the individual monitoring and adjustment of bass, mid and high ranges.

Remote monitoring and control

Remote control capability / network compatibility using a laptop, wall installation modules or media control systems.

8 input switching contacts

The FC-9 has 8 input contacts. The inputs can be utilized to switch between the different presets of the FC-9, as well as other Fohhn-Net devices. With two inputs and two pushbuttons (shutters) connected to them, a volume control can be realized as well.

4 inputs / 6 outputs (24 nodes)

A programmable 10-band parametric EQ, compressor/ limiter/noise gate, delay, X-over function, top-quality pink noise and sweptone generator are available at each output, allowing you to conveniently adapt the Fohhn system to the room acoustics or your own personal requirements.

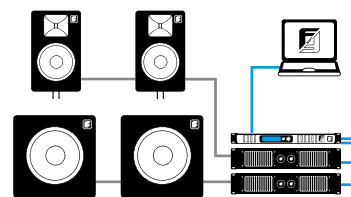

2x Sub passive / 2x Top passive
2x standard amplifiers
1x DSP system controller FC-9

Remote control and network ability of Fohhn devices with integrated DSP

FR-10

remote control wall panel designed for the remote operation of Fohhn devices with integrated DSP.



Description

The FR-10 is a wall mount remote control module designed for the remote operation of Fohhn DSP amplifiers, DSP controllers and active Fohhn speakers systems. The FR-10 is extremely easy to operate because the controls are so well arranged. It is virtually impossible for the end customer to make operating errors because the only operating elements are the 8 labelled buttons.

Easy handling

Control up to 32 Fohhn devices individually with this stylish FR-10 wall panel. 8 programmable buttons can be configured to control the overall volume of a system, the volume in different zones or presets for different room effects, for example. The system also has a special function that confirms whether all commands have been executed successfully. The buttons indicate this by changing red or green shortly after they are pressed. For example, if a device is not switched on, the button changes red to indicate that a command could not be executed. This additional monitoring function ultimately contributes to the overall operating reliability of your system. The wall panel is easy to configure using a standard computer with intuitive Fohhn-Net Remote software installed.

Connections

Two terminal strips (paralleled). Alternative connection via standard 4-wire telephone cable.

Applications

The FR-10 is ideal for training rooms, hotels, churches, halls, restaurants or any venue where a simple, efficient system is required to control your audio equipment from a central location.

The FR-10 is also ideal for projects where complex media control systems are not viable or inappropriate, but the user wishes to control the speaker system centrally.

FR-20

19" remote control unit can be controlled via conventional external buttons or switches.



Description

The FR-20 can be controlled via conventional external buttons or switches (e.g. Jung, Vitra, etc.) or switching contacts (e.g. media control system). Buttons and switches may come in the form of a wall installation module or an individually manufactured control panel, for example.

Presets stored in the connected Fohhn DSP devices are activated simultaneously and settings for different scenarios such as speech, music, empty room, full room, etc are loaded when the buttons/switches are pressed. You can also adjust the volume quickly and easily in 1 dB increments using the FR-20. A maximum of 31 Fohhn devices connected to the network can be activated simultaneously at the press of a single button.

Integration in a media control system

The FR-20 allows the convenient integration of all DSP-controlled Fohhn devices into media control systems (e.g. AMX, Crestron) by means of 8 switching contacts or RS-485 interface.

Integration in a EIB bus technology

One building, one concept, one system.

Fohhn systems equipped with a FR-20 distribution switch comply with the „European installation bus technology“ standard, including all operating comforts.

Applications

The FR-20 is ideal for training rooms, hotels, churches, halls, restaurants, clubs, bars and many other venues.

For simple, reliable remote operation of your audio system without having to install complex, expensive media control systems.



Accessories for AT-201

WAT-08k

Wall bracket short, universal adjustment 360° for AT-05/061/07/08/09/10/201, AL-50/100/150

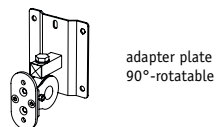

adapter plate
90°-rotatable

WAT-08

Wall bracket, universal adjustment 360° for AT-05/061/07/08/09/10/201, AL-50/100/150

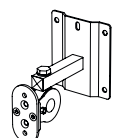

adapter plate
90°-rotatable

WAT-12

Wall bracket, universal adjustment 360° for AT-30/35/40 and heavy duty also for AT-08/09/10/201

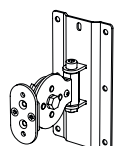

adapter plate
90°-rotatable

QAT-20

Horizontal bracket for AT-201

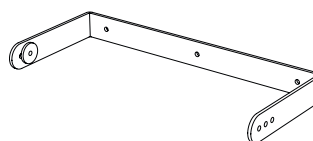

VAT-20

Vertical bracket for AT-201 pivots and tilts

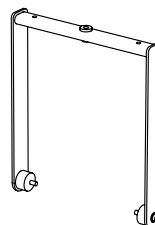

EB-8

Ring stud DIN 580, zinc, for safety M8 thread for AT-201/30/35/40/50/66



Views of AT-201

Front view

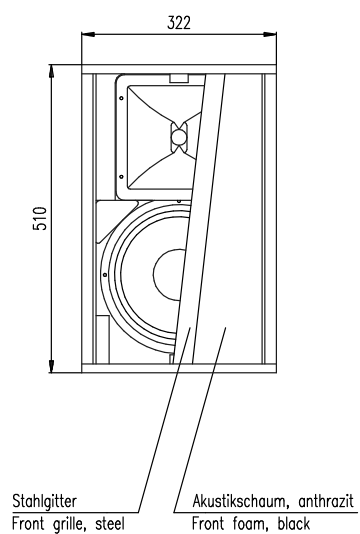

Side view

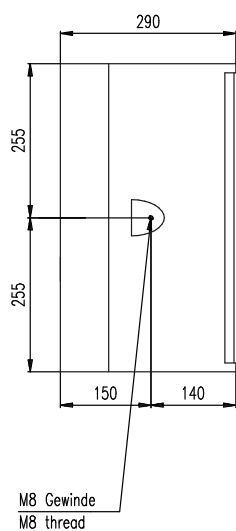

Top View

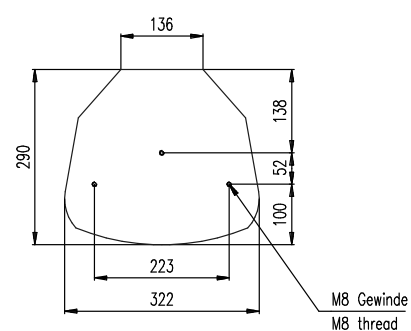

Rear view

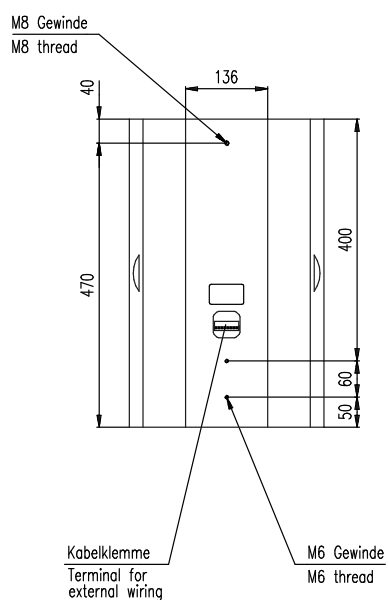

Bottom view

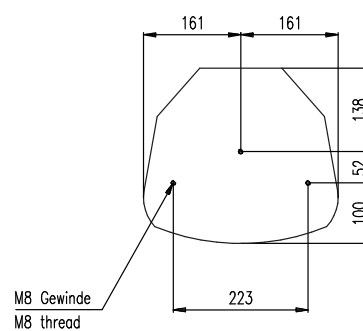

WAT-08k

Wall mount

Side view

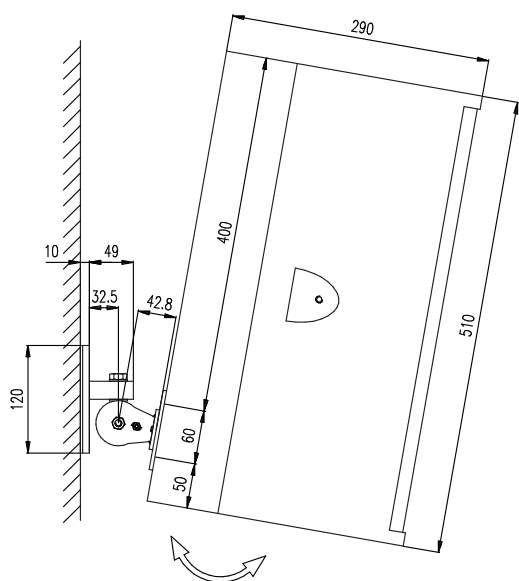

Rear view

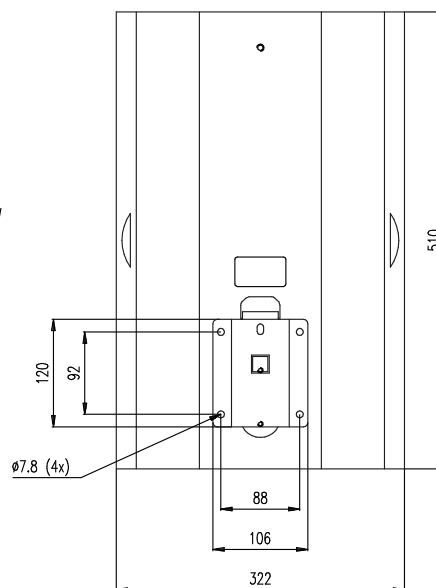

Top view

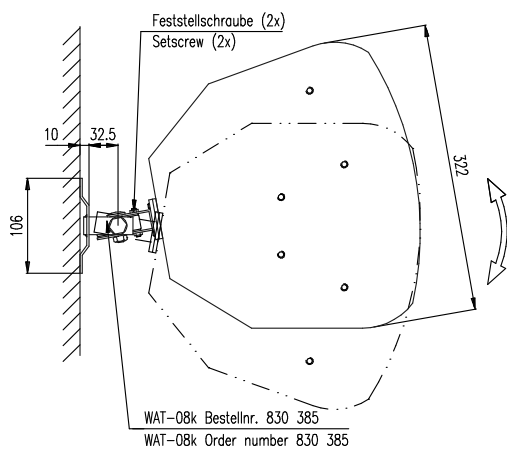

WAT-08

Wall mount

Side view

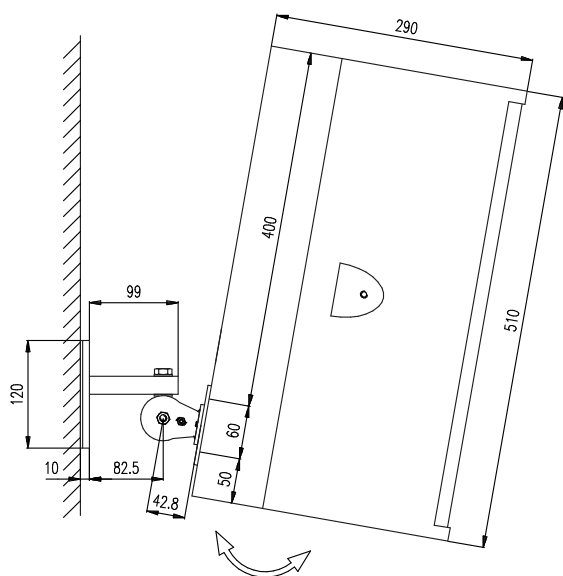

Rear view

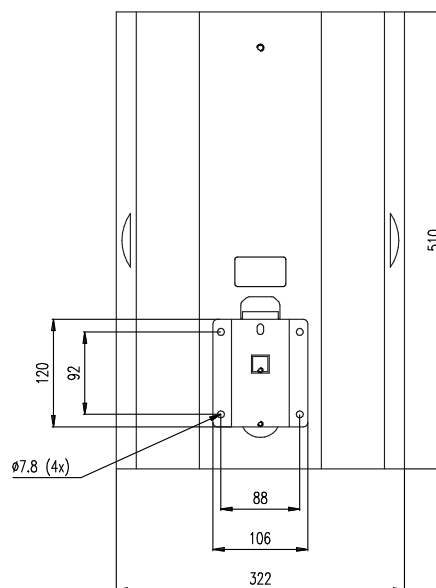

Top view

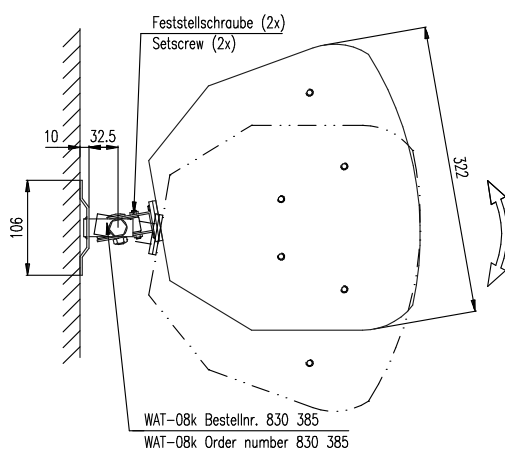

WAT-12

Wall mount

Side view

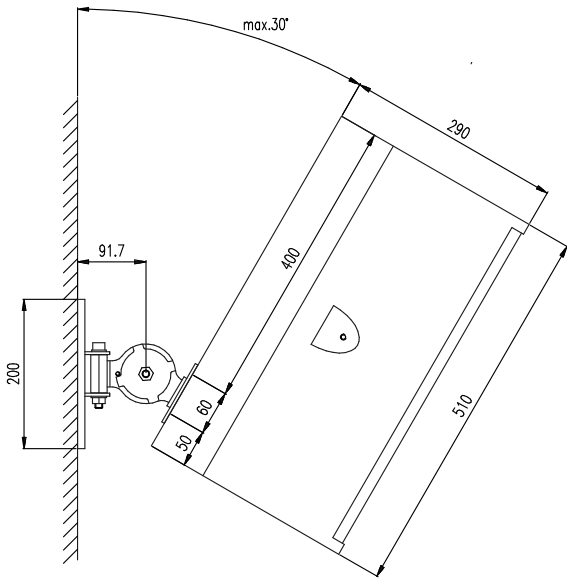

Rear view

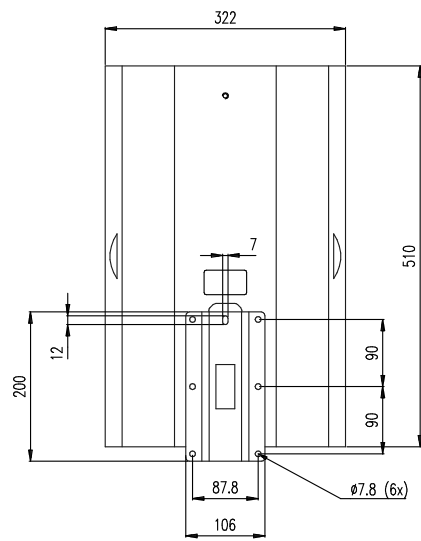

Top view

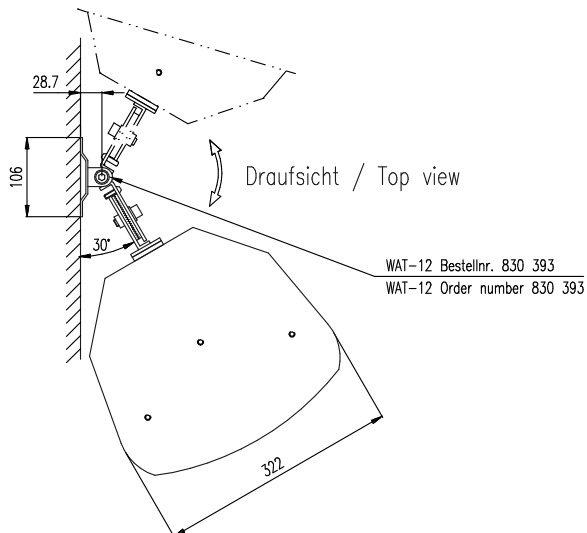

VAT-201

Traverse mount

Side view

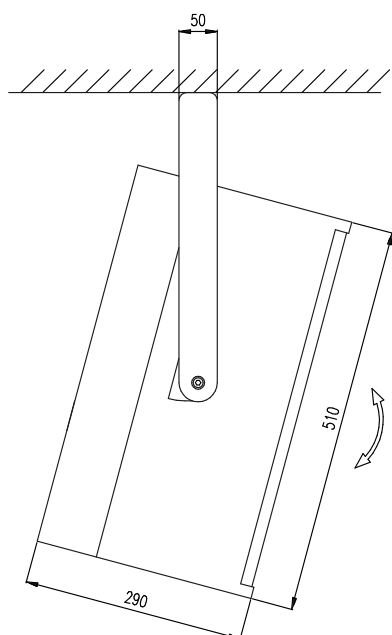

Rear view

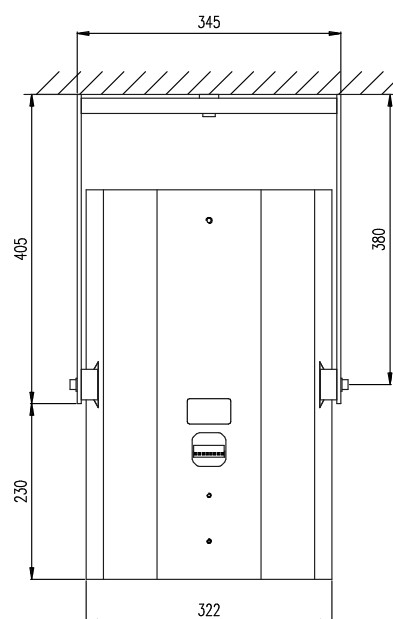

Top view

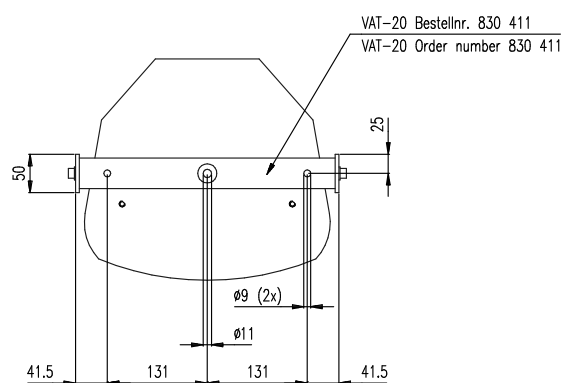

QAT-201

Horizontal mount

Side view

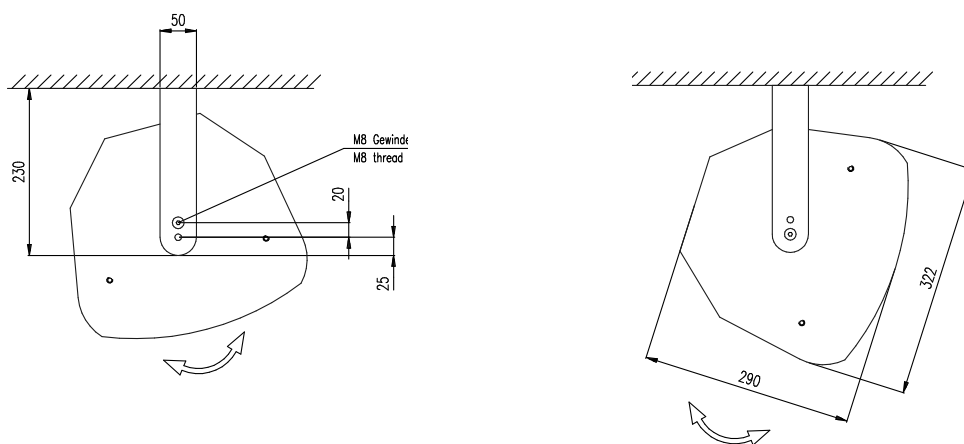

Front view

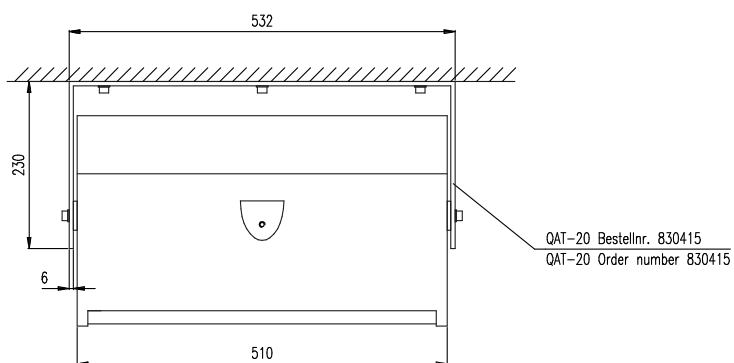

Top view

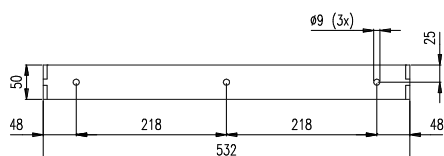

Tender specifications

High-performance 2-way passive speaker

High-performance 2-way passive speaker, equipped with one 10"-sub-mid speaker and one 1"- HF-driver on a 90° revolvable CD horn in time-aligned speaker arrangement. The speaker is temporary able to work under 1200 W and generates acoustic pressure of maximal 129 dB. In a wide frequency range of 65 Hz to 20 kHz, the speaker has a defined dispersion of 90° x 60° or 60° x 40° (h x v). High-tensile multiplex birch wood enclosure with rounded sides, strutted with internal metal brackets to maintain safety instructions. Durable textured finish, available in black or white. Optional available in all RAL-colours or in weatherproof polyurethane-coating with impregnated speaker membranes. For the protection of the speaker chassis and the electronics, the enclosure is equipped with a ball impact resistant, extremely sound-permeable front grille, which is made of powder-coated steel and equipped with a moisture- and dust repellent acoustic foam in enclosure colour. Nine pieces M8 and two pieces M6 thread applications in ground, back and upper side are integrated to the admission of ring studs and system brackets. The loudspeaker system is optionally available with 100V technology in different performance classes up to 240 W. Connections: screw- and pluggable 8-pin Phoenix terminal, which is very easy to assemble. All contacts exist twice, to connect very easy and safe to the next speaker. Specific brackets to assemble the system on ceilings, walls and traverses are available. Simulation data CAAD for EASE are available.

electro-acoustical features

acoustic design	passive loudspeaker, 2-way, bass reflex
components	10" / 1" on rotatable CD-horn, with self-resetting IPC-HF
protection	
power rating (nominal)	300 W
power rating (program)	600 W
power rating (peak)	1200 W
sensitivity	97 dB
maximum SPL	127 dB
frequency range	65 Hz – 20 kHz
nominal dispersion (h x v)	90° x 60° or 60° x 40°
nominal impedance	8 ohms

features

enclosure	birch plywood cabinet, metal strengthened
protection grille	ball impact resistant metal, powder coating
rigging points	9x M8 und 2x M6 thread
connections	8-pole Phoenix connector
frontal design	acoustic foam, same colour as enclosure
dimensions (W x H x D)	330 x 510 x 300 mm
weight ^[7]	14.5 kg

optional features

integrated 100 V-transformer	60/30/15 W, 120/60/30 W or 240/120/60 W
optional colours	all RAL-colours
weather protection	scratch-proof plastic coating, impregnated speaker membranes

CAAD simulation data

EASE

Make
Type

Fohhn Audio AG
AT-201

SOUNDS PERFECT. IS PERFECT.

Fohhn audio systems. The ultimate all-round audio experience.



■ German quality
■ engineered and made
■ by Fohhn®

Fohhn Audio AG

Hohes Gestade 3-7

72622 Nürtingen

Germany

Tel. +49 7022 93323-0

Fax +49 7022 93324-0

www.fohhn.com

info@fohhn.com