

# HDL 10-A Large Suspended System

## System Configuration

### DESCRIPTION

Large Suspended System to cover an area of 65 (L) x 40 (W) m with a stage of 15 (W) m.

Arrays are suspended at 9m from ground level. Minimum point is at 5m from the ground level. Direct Sound Pressure level target is 100dB in the range of 400-4000Hz.

### SYSTEM SPECIFICATION

12 nos. modules of HDL20A per side in suspended configuration. DSP settings and relative splay angles are shown in the chart below. Suggested Crossover Frequency 80Hz

## List of Equipment

QUANTITY	MODEL	DESCRIPTION	PART NUMBER
24	HDL 10-A	active line array module	13040016 (230V) BLACK 13040017 (115V) BLACK 13040022 (230V) WHITE 13040023 (115V) WHITE
16	SUB 8006-AS	active high power subwoofer	13000372 (230V) 13000373 (115V)
2	FLY BAR HDL 10	suspending bar for HDL20-A line array system	13360275
40	XLR CONNECTOR	audio connection cable between the boxes	-
2	FLY BAR PICKUP HDL 20	to be added to the fly bar accessory in case the pick up is made with 2 motors	13360221

## Recommended Accessories

QUANTITY	MODEL	DESCRIPTION	PART NUMBER
12	RAIN COVER HDL SERIES	4 Rain cover for HDL 20-A and HDL 10-A	13360283
6	KART HDL 10	The heavy duty RCF KART HDL10 can be use to easily transport up to 4 HDL 10-A cabinets.	13360275
16	AC PRO WHEELS	Kit no 4 swivel castor, 100mm / 4" Ø wheel with roller bearings	13360238
1	AC POWER CABLE 6XTTL55	AC Cable to power up to 6 TTL55-A or TTS56-A amplifiers	13360138
1	AC POWER EXTENSION TTL55	AC power cable extension 20 meters	13360146
1	AC POWER BOX 6XTTL55	euopean stage box to power 6TTL55-A line array modules	13360145
4	SAFETY CHAIN TTL55	to be added to the fly bar to provide a secondary safety	13360128
2	AC 4 PIN HDL 20 FRAME	4 quick frame lock pins kit for HDL 20-A and HDL 18-AS array system	13360222
2	AC 4 PIN HDL 20 FRONT	4 quick front lock pins kit for HDL 20-A and HDL 18-AS array system	13360219



# HDL 10-A Large Suspended System

## System Configuration

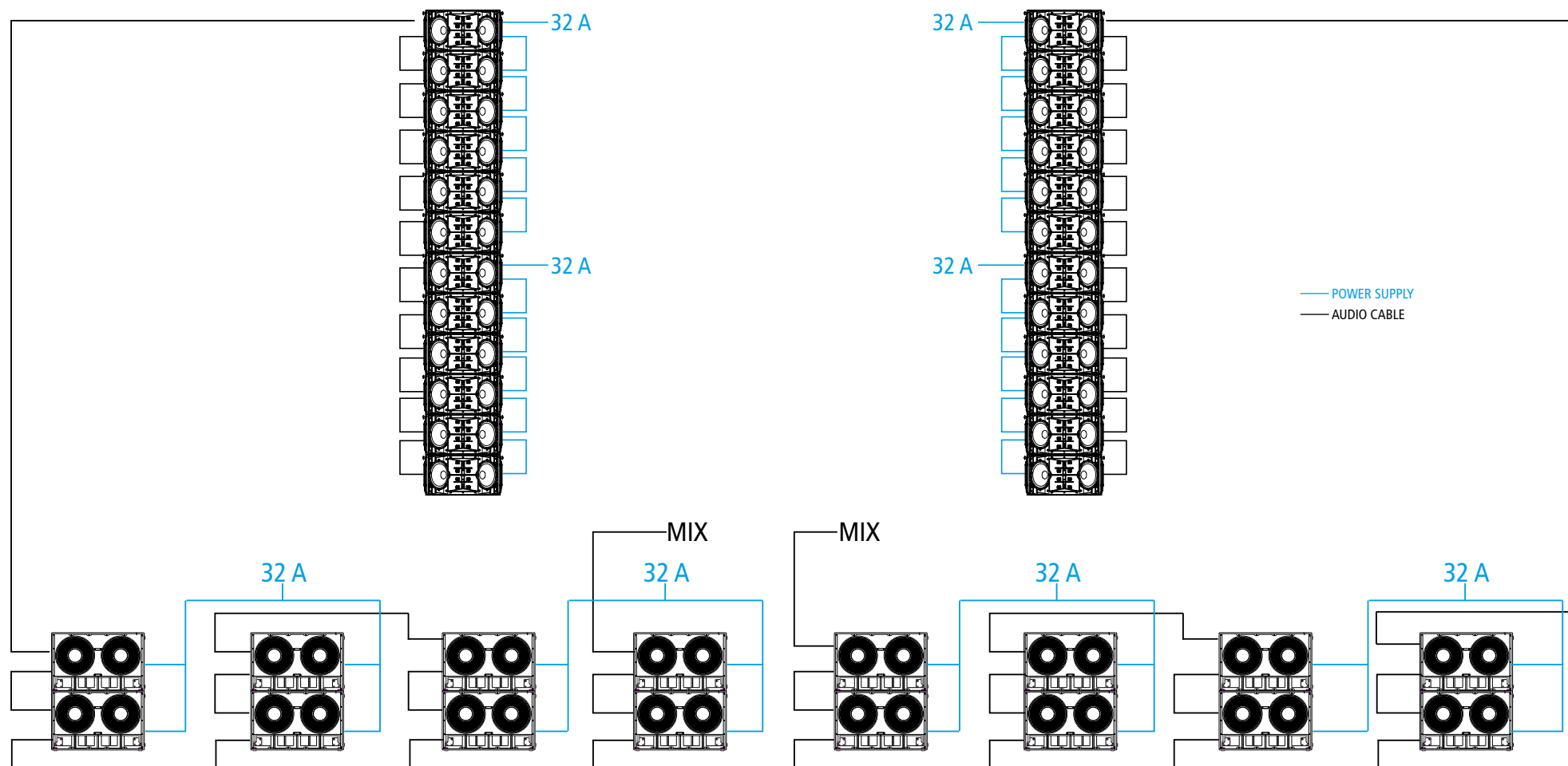

For its array systems, RCF has developed a dedicated configuration tool "RCF Shape Designer" that allows you to simply get all necessary mechanical and digital-processing set-up data ([http://www.rcf.it/en\\_US/products/touring-and-theatre/rcf-shape-designer](http://www.rcf.it/en_US/products/touring-and-theatre/rcf-shape-designer)).

RCF makes also available on its website all the speaker system data in "GLL" format for predicting the performance of loudspeaker systems in a suggested acoustical environment by using the several AFMG software tools ([www.AFMG.eu](http://www.AFMG.eu)).

RCF Engineering Support Group is at your disposal for any information and clarification you might require [techsupport.pro@rcf.it](mailto:techsupport.pro@rcf.it)

