

Data sheet

LX-100



# Linea-Series

Directional Speakers.



FOHNN®  
HYBRID LINE ARRAY TECHNOLOGY





Linea LX-100 is a high-quality sound system that incorporates sophisticated 2-way speaker technology. A total of eight 4" high-performance line array speakers and one 1" compression driver with advanced HF Waveguide system produce sound with accurate, cylindrical dispersion characteristics (line array principle).

### Description

#### Next Generation Mini Line Array Systems

Linea LX-100 is a compact Mini Line Array System, specially designed to give top quality reproduction of both, speech and music. The elegant, lightweight speakers can be installed and set up in minutes. The system has proved popular with sound engineers, musicians and DJs on account of their excellent sound quality, even coverage and lack of feedback. The speakers' slim, unobtrusive design integrates seamlessly into stage areas and room architecture, appealing to event organizers, agencies and audiences.

In the LX-100 eight 4" neodymium drivers produce sound with accurate cylindrical dispersion characteristics in the mid-low range. At the top end an 1" compression driver with Fohhn® Waveguide ensures the cylindrical wave's continuation up to the highest audible frequencies. Speaker adjustment is done by an integrated crossover with Intelligent Protection Circuit (IPC) to guard against overload.

Our engineering team developed the unique Fohhn Hybrid Line Array principle by combining, for the first time ever, high performance bass-mid speakers and 1" compression drivers with a Waveguide system. The result – a new generation of high powered Mini Line Array Systems. The Fohhn Hybrid principle has led to the achievement of outstanding sound quality in speech and music, superb dynamics and even coverage of audience areas.

The LX-100 is fully compatible with the Fohhn system concept. The LX-100 can be effectively teamed with the AS-10, AS-20, AS-30 or XS-10, XS-20, XS-30 subwoofer.

In 2009 our Linea Live III system won a "Tastenvelt" Readers' Award. Since then, both press and end users have referred to us as the "innovative Mini Line Array System specialists".

PC datenfiles for the simulation programmes ULYSSES and EASE are available.

### Accessories for professional live applications

#### Mobile applications

Stand adapter, speaker stands, distance piece. Attaching the Linea LX system to a speaker stand or distance piece using the optional SA-6 stand adapter requires only a few moves. The sound is directed straight onto the audience. The angle of the Linea LX system can be adjusted in increments of 3.8° and locked. For maximum sound quality and speech intelligibility. We also offer robust padded carrier bags for transporting the Linea LX system (with stand adapter attached). These bags provide adequate protection for your equipment.

#### Flown applications

The SA-7 adapter is perfect for setting up safe flown applications. Linea LX systems can be secured to vertical or horizontal supporting members. The adapter SA-7 consists of an articulated fixture with TV spigot that can be locked at 3.8° increments. You can set up safe, flown applications by attaching the Linea LX system to the supporting member using an optional clamp, half coupler or similar item.

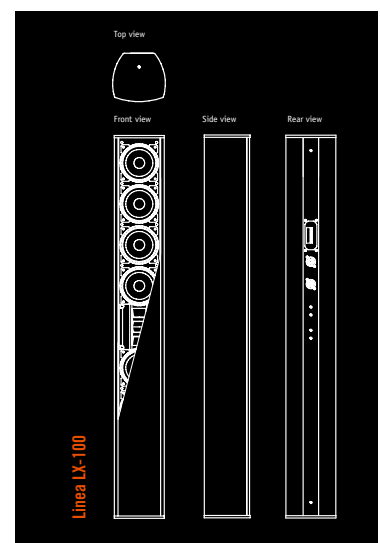

## Controlling Linea LX speakers

We always integrate a sophisticated passive crossover with electronic high-frequency protection so you can operate the LX-100 with any professional amplifier. For maximum sound performance and operating reliability, we recommend our digital DSP amplifiers (e.g. D-2.750, D-4.750 or D-2.1500). Its integrated DSP technology includes a number of factory loudspeaker presets. These guarantee total operating reliability and superb performance at any sound pressure level. Programmable audio tools, such as the 10-band parametric EQ, enable quick adjustments to suit the room acoustic and any related microphone set-ups. All DSP functions can be carried out remotely using a laptop.

## DSP technology

Fohhn® DSP processor technology modulates the Linea LX-100 and Fohhn subwoofers perfectly. Digital Fohhn signal processors are integral components of active Fohhn subwoofers, Fohhn DSP amplifiers and Fohhn DSP controllers. DSP-controlled Fohhn devices can be controlled remotely from a central location in the room or on the stage via intuitive remote control units. Fohhn therefore offers a perfectly adapted sound system that fulfils all the requirements of a modern speaker system regarding design, sound quality and operating comfort in every respect.

## Accessories

L-bracket WAL-1, wallbracket WAT-08k / WAT-08 / WAT-12, Stand adapter: pivot reducing flange SA-6, SA-7 for flying applications, Free Stands II and III.

## Applications

Churches, museums, castles, conference rooms, hotels ...

## Optional versions

Optional 100 volts version. All RAL colours.

## Connectors

2 Speakon sockets and 8-way Phoenix terminal strip, two adjacent pins are always connected in parallel to loop through another speaker system.

LowZ Version (low impedance)

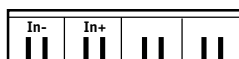

100 volts version with pickups

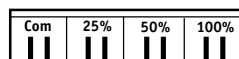

## Technical specifications

### electro-acoustical features

acoustic design	passive line source speaker system, 2-way
components [*]	8x 4" impreg. speaker membranes and 1x 1" on Waveguide, (fully neodymium)
power rating (nominal) <sup>[1]</sup>	400 W
power rating (program) <sup>[2]</sup>	800 W
power rating (peak) <sup>[3]</sup>	1600 W
sensitivity <sup>[4]</sup>	94 dB
maximum SPL <sup>[3]</sup>	126 dB
frequency range <sup>[5]</sup>	65 Hz – 20 kHz
nominal dispersion (h x v) <sup>[6]</sup>	140° x 25°
nominal impedance	8 ohms

### features

enclosure	Aluminium design
protection grille	ball impact resistant metal, powder coating
suspension points	8x M6 thread
connectors	2x Neutrik NL4 Speakon, 8-pin Phoenix terminal
standard colours	black or white powder coating
front design	metal grille in enclosure colour
dimensions (W x H x D)	130 x 990 x 120 mm
weight <sup>[7]</sup>	7 kg

### optional features

integrated 100 V-transformer	60/30/15 W
optional colours	all RAL-colours

### weather resistance

weather resistance	-
--------------------	---

### CAAD simulation data

CAAD simulation data	ULYSSES, EASE
----------------------	---------------

The manufacturer reserves the right to make technical modifications according to legal regulations stipulating the continual improvement of product features.

<sup>[1]</sup> according to IEC-60268-5 long term

<sup>[2]</sup> according to IEC-60268-5 short term

<sup>[3]</sup> Peak, 20 ms with bandpass filtered pink noise signal according to IEC 60268-2 at one octave above the lower limit of the frequency range

<sup>[4]</sup> 2,83 V at 8 ohms (2 V at 4 ohms, 4 V at 16 ohms) at a distance of 1 meter under anechoic fullspace conditions

<sup>[5]</sup> -10 dB under anechoic halfspace-conditions

<sup>[6]</sup> horizontal x vertical at -6 dB, averaged 1-4 kHz

<sup>[7]</sup> net weight without optional equipment

<sup>[\*]</sup> Intelligent Protection Circuit. Voltage-controlled semiconductor circuit protecting the HF-driver against overload highly effective and with very short attack time.



### Fohhn® Hybrid Line Array technology.

**Fohhn® Linea Live Systems redefine the concept of balanced sound, excellent sound quality and sophisticated design.**

Fohhn's specially developed Hybrid Line Array Technology integrates high performance, vertically aligned loudspeakers and powerful high frequency drivers with Waveguide in a compact housing.

Systems from the Fohhn Linea LX series have a hybrid design that is based on a combination of classic two-way speakers and modular line array, and incorporates the functional advantages of both principles.

For many years we have carried out research and development in the field of high powered Mini Line Array Systems. Our original aim was to take the benefits associated with large modular line array systems such as directionality, even coverage, long throw and transport them into more compact, easy to install systems. We successfully achieved our aim in 2006 with the release of our Linea-Series. By 2007 our Linea LX systems had set new standards for line source column speakers. Our engineering team developed the unique Fohhn Hybrid Line Array principle by combining, for the first time ever, high performance bass-mid speakers and 1" compression drivers with a Waveguide system. The result – a new generation of high powered Mini Line Array Systems. The Fohhn Hybrid principle has led to the achievement of outstanding sound quality in speech and music, superb dynamics and even coverage of audience areas.

### Linea LX: An overview of the main advantages

#### \* First-class sound with excellent dynamics

Whether used for full-on live music and DJ events, or for demanding speech applications, Linea LX systems guarantee superb sound quality at any loudspeaker level.

#### \* Even sound distribution with Fohhn Hybrid Line Array Technology

Compared with conventional systems, sound is distributed much more evenly throughout the room, with a pleasing effect at the front and clear, coherent sound right at the back.

#### \* Superb speech intelligibility

Sound can be specifically targeted towards the audience, avoiding unwanted reflections from the ceiling or floor. For the listener, the result is clear and pleasant. Speech intelligibility is considerably improved.

#### \* Perfect integration into room architecture and stage designs

The elegant designer speakers integrate extraordinarily well into their surroundings. They won't interfere with either stage designs or camera shots.

#### \* Disturbance-free listening

Feedback is rarely an issue, even with complex microphone set-ups.

#### \* Easier transportation and quicker set-up

Linea LX speakers are equipped with state-of-the-art, lightweight neodymium loudspeaker technology. Conveniently positioned handles ensure quick and safe set-up. The speakers' compact dimensions reduce the amount of space needed for storage and transportation.

#### \* No need for expensive rigging or curving.

Compared with modular line array systems, no expensive flying mechanisms, rigging or curving are necessary. All the line array technology is integrated into a single housing, enabling quick and easy installation.

## The difference is the detail.

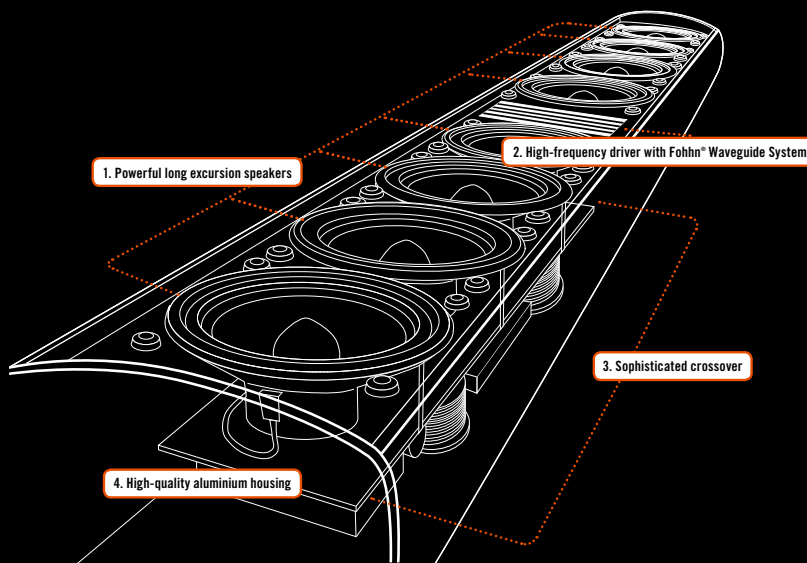

### 1. Powerful long excursion speakers guarantee outstanding dynamics.

Extremely powerful 4" long excursion speakers manufactured by using state-of-the-art neodymium technology guarantee resonant, dynamic reproduction of vocals and instruments. The coated weatherproof membranes are exceptionally resilient and capable of reproducing sound without distortion. The speaker chassis are arranged at close proximity in a perfect line and generate a cylindrical wave in the mid range.

**2. High-frequency driver with a Waveguide Systems guarantees crystal clear high notes and excellent sound dispersion characteristics.** A powerful 1" neodymium high-frequency driver with upstream Fohhn Waveguide system produces crystal clear high tones and defined sound dispersion characteristics. The Waveguide extends the cylindrical wave from the mid range to the highest frequencies. Conventional column speakers operate entirely without high frequency systems.

### 3. A sophisticated crossover adapts the speakers perfectly.

A sophisticated crossover with selected components and electronic Fohhn IPC speaker protection is the perfect interface between the 4" chassis and the high-frequency driver. Conventional column speakers usually operate without a crossover.

**4. The high-quality aluminium housing is ideal for mobile sound applications, fixed installations and weatherproof applications.** Linea LX system housings are manufactured from high-quality profiled cast aluminium, are extremely robust and provide a maximum protection for all internal components. The elegant housing is available in anodised black as standard as well as all RAL colours on request.

# PERFECT DIRECTIONALITY. PERFECT SOUND.

An incredible listening experience, from the front row to the very back row.

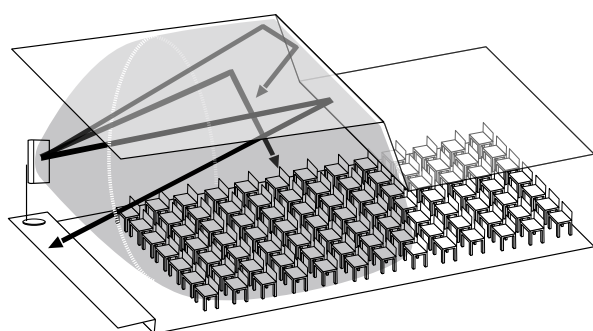

## PA systems with conventional speakers

In comparison with line array systems, conventional loudspeakers offer a less directional coverage, particularly in the vertical plane. Levels at the front are often too loud, while at the back, the sound may be too quiet or lacking in clarity due to insufficient reach.

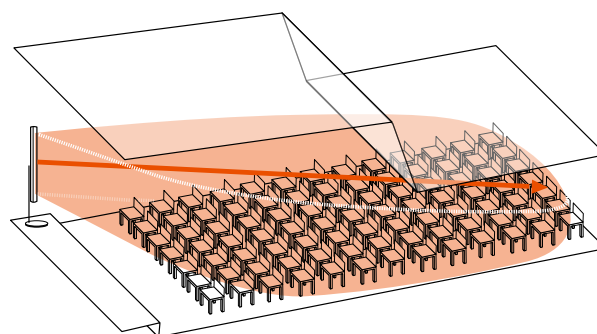

## Linea systems for sound

The cylindrical dispersion characteristics of Fohhn's Linea Live Mini Line Array Systems give a more targeted sound transmission to audience areas. The speakers also provide a more even room coverage, from the front row right to the very back. Potential reflections from the ceiling, floor or walls can be avoided, making the sound clearer and more pleasant for the audience, with dramatically improved speech intelligibility. The effect is also better for musicians or public speakers, with less sound from the room reflecting back onto the stage.

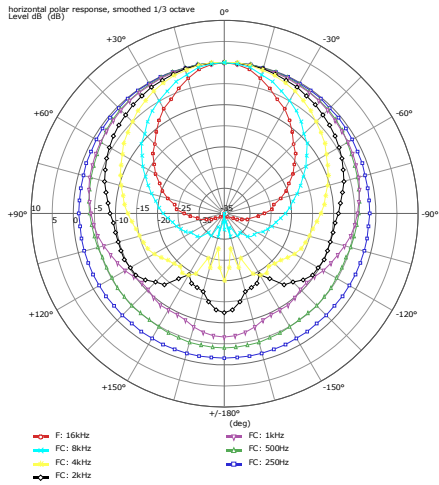

Fig. 1: Horizontal polar pattern

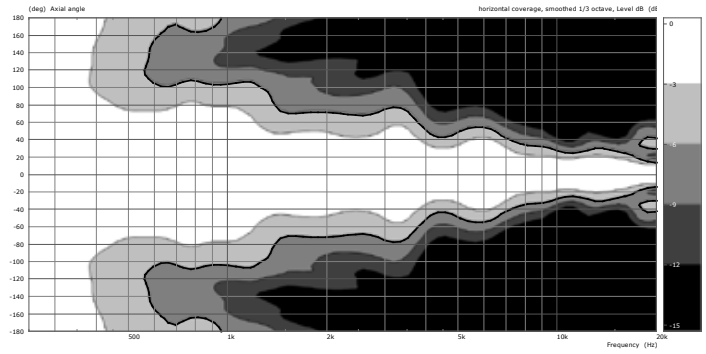

Fig. 2: Horizontal coverage

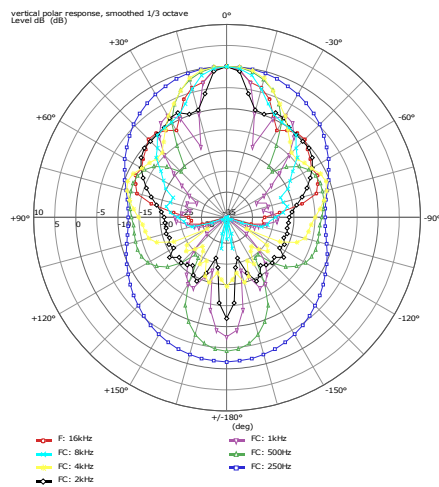

Fig. 3: Vertical polar pattern

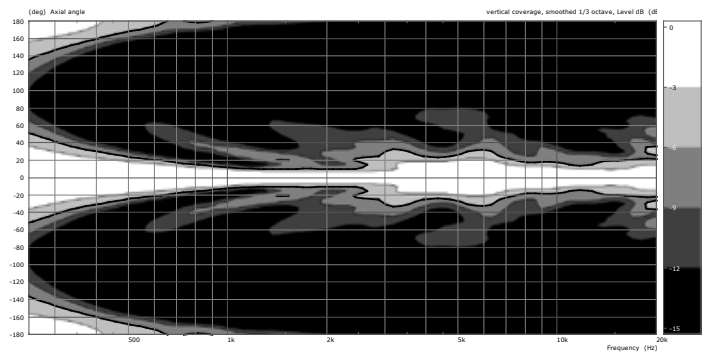

Fig. 4: Vertical coverage

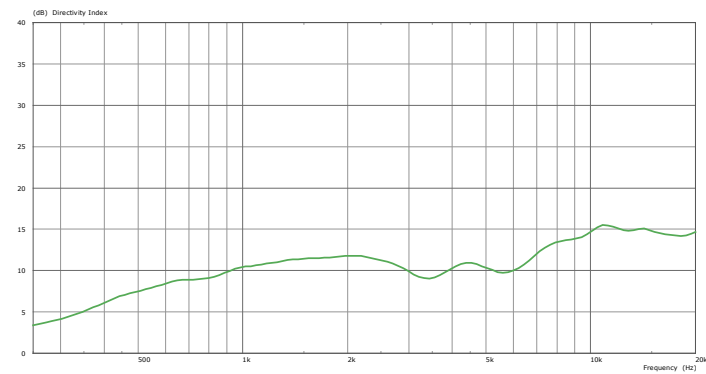

Fig. 5: Directivity index

Fig. 6: Frequency response

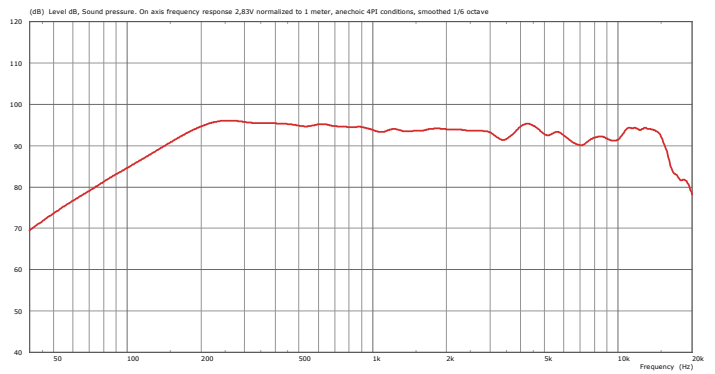

Fig. 7: Impedance

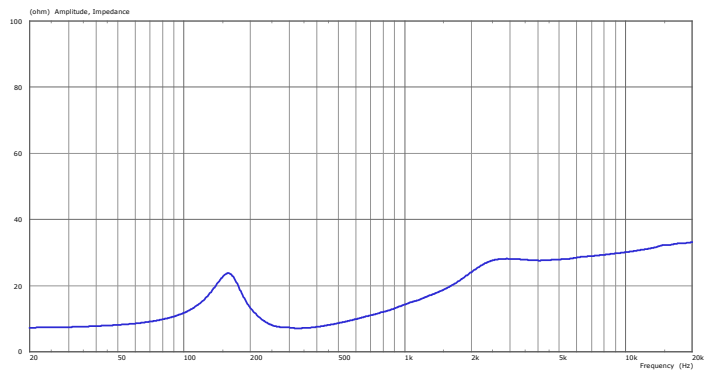
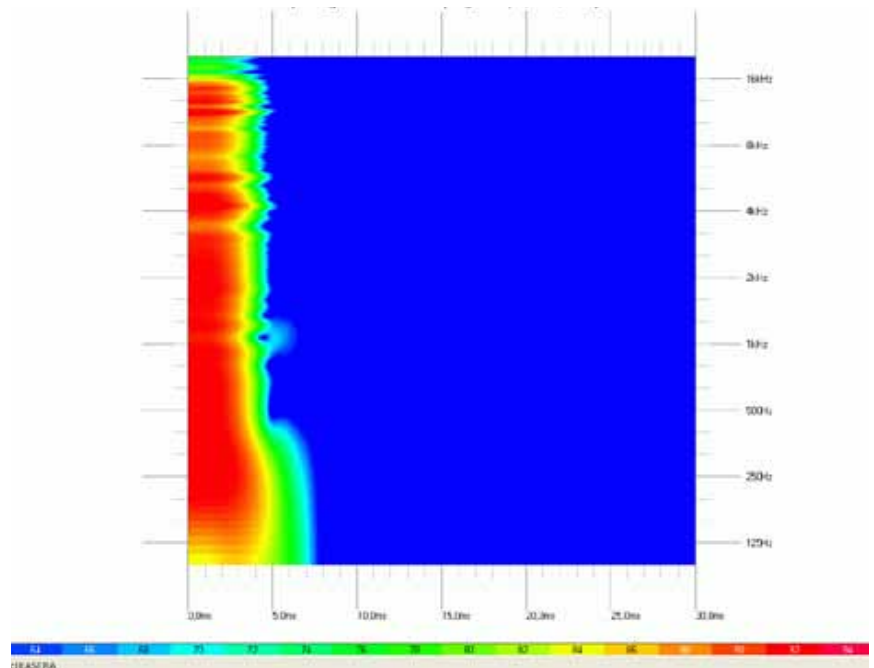

Fig. 8: Spectral decay





## Controlling Linea-Series speakers

Fohhn offers a range of specially adapted system DSP amplifiers for controlling Arc speaker systems, which guarantee maximum sound performance and operational reliability for your Fohhn products. As manufacturers of speaker, amplifier and DSP technology, we know our systems inside and out right down to the smallest detail and are therefore in a perfect position to provide our users with the best overAL--l system.

### Fohhn System DSP amplifier are offering following advantages:

#### Integrated high-performance DSP technology:

- quick set-up,
- minimal space requirements in electronics cabinet,
- minimal cable requirements,
- fewer cable faults,
- controller and amplifier can be controlled and monitored using the same software.

#### Dual DSP technology

The DSP amplifiers contain 2 separate DSP engines with enormous capacity and processing power for 5 digital audio devices (DSP-1) and Fohhn specific speaker databases (DSP-2).

#### Remote monitoring and control

Integrated temperature and operating time monitor, status indicator / protection, remote control capability / network compatibility using a laptop, wall installation modules or media control systems.

### Fohhn® dual DSP technology

#### DSP-1: Integrated digital audio devices

Each amplifier channel has a:

- programmable 10 band parametric EQ,
- compressor/limiter/noise gate,
- delay,
- X-over function,
- top-quality pink noise and sweeptone generator

#### DSP-2: Speaker management

An integrated speaker database guarantees excellent sound quality and protection for all Fohhn speaker types. A sophisticated algorithm developed by Fohhn engineers and adapted to each speaker allows the individual monitoring and adjustment of bass, mid and high ranges.

## 1.1 Amplifier recommendations for the Linea-Series



### D-2.750

**2 channel operation**, 2x 750 W / 4 ohms, 2x 390 W / 8 ohms

Fohhn Audio DSP, display, remote control

### D-4.750

**4+2 channel operation**, 4x 750 W / 4 ohms, 4x 390 W / 8 ohms

**2x DSP line out channels for controlling a conventional amplifier**

Fohhn Audio DSP, display, remote control

	Arc-Tops										Linea		Arc-Subs										
	AT-05	AT-061	AT-07	AT-08	AT-09	AT-10	AT-201	AT-22w	AT-30	AT-35	AT-40	AT-50	AT-66	LX-100/150	AS-10	ASP-10	AS-20	ASP-20	ASP-30	ASP-30	AS-40	ASP-40	
D-2.750	x	x	x	x	x	x	x	x	x					x	x	x	x						
D-4.750	x	x	x	x	x	x	x	x	x					x	x	x	x						
D-2.1500										x	x	x	x	x					x	x	x	x	
D-4.1200										x	x	x	x	x					x	x	x	x	

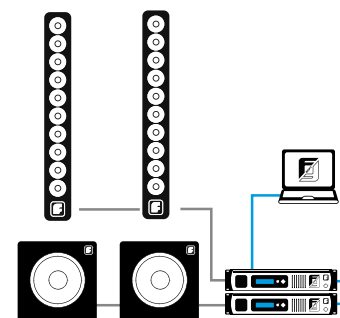

2x Sub passive / 2x Top passive  
2x DSP amplifier

## Controlling Linea-Series speakers

### 2. Standard amplifiers combined with Fohhn controllers

#### Standard amplifiers / 100V amplifiers / multichannel amplifiers combined with Fohhn FC-9 DSP system controllers

All of the speaker systems in the Fohhn Linea-Series can be operated in combination with standard amplifiers (e.g. Bittner amplifiers). Each Fohhn speaker model has a linear design, neutral sound adaptation function and is fitted with an integrated crossover with electronic tweeter protection.

We recommend integrating the FC-9 Fohhn DSP system controller for applications involving standard multichannel amplifiers, 100V amplifiers or monitored amplifiers according to EN 60849.

The FC-9 guarantees maximum sound quality, operational reliability and performance features that no other standard controller can offer in combination with our Fohhn speakers.

#### Sound quality. Reliability. Intelligent control.

- \* Fohhn DSPs guarantee maximum sound performance
- \* 5 premium audio tools such as Parametric EQ are integrated
- \* Integral speaker and amplifier database for maximum operating reliability
- \* Remote monitoring/operation, network-compatible
- \* Automatic amplifier calibration function CAS
- \* 8 input switching contacts for easy system integration
- \* Perfect adaptation to all standard amplifiers

#### FC-9 DSP system controller



DIN EN 60849 (VDE 0828)

#### Bittner amplifiers



**BITTNER**  
AUDIO

In addition to our special Fohhn® DSP amplifiers, we also offer the complete range of **amplifiers manufactured by Bittner Audio** for low-ohm or 100 volt applications. Bittner Audio offers solutions such as multichannel amplifiers with eight standard channels and **important features for integration in electroacoustic emergency warning systems according to DIN EN 60849 (VDE 0828)**. Contact us for more information!

#### Advantages of the FC-9 controller:

##### Perfect adaptation to all standard amplifiers

Automatic amplifier calibration function and integrated amplifier database for perfect adaptation.

##### Dual DSP technology

The FC-9 contains 2 separate DSP engines with enormous capacity and processing power for Fohhn specific speaker databases and 5 digital audio devices.

##### Integrated speaker database

Guarantees excellent sound quality and protection for all Fohhn speaker types. A sophisticated algorithm developed by Fohhn engineers and adapted to each speaker allows the individual monitoring and adjustment of bass, mid and high ranges.

##### Remote monitoring and control

Remote control capability / network compatibility using a laptop, wall installation modules or media control systems.

##### 8 input switching contacts

The FC-9 has 8 input contacts. The inputs can be utilized to switch between the different presets of the FC-9, as well as other Fohhn-Net devices.

##### 4 inputs / 6 outputs (24 nodes)

A programmable 10-band parametric EQ, compressor/ limiter/noise gate, delay, X-over function, top-quality pink noise and sweptone generator are available at each output, allowing you to conveniently adapt the Fohhn system to the room acoustics or your own personal requirements.

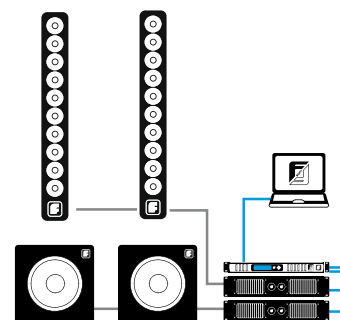

2x Sub *passive* / 2x Top *passive*  
2x standard amplifiers  
1x DSP system controller FC-9



# LINEA LIVE

Mini Line Array Systems



From more precise speech delivery to full-on live music, Fohhn® Linea Live guarantees the very best sound quality.

## AN UNBEATABLE SYSTEM.

A perfect combination: Linea LX Mini Line Array Systems and DSP-controlled active subs

**\* Fohhn® Hybrid Line Array Technology**

Ensures excellent sound reproduction in every part of the venue: Superb speech intelligibility and a balanced, homogenous image, even in more difficult acoustic conditions with long reverberation times.

**\* Fohhn® Audio DSP / Active Subwoofers**

Two separate stereo DSP processors in each of our active subs' high-powered amplifiers ensure maximum reliability and superb performance as well as offering remote control options.

**\* Fohhn® Audio Soft**

Perfect control of all connected audio devices via laptop with Fohhn's easy-to-use, intuitively usable software.

## Controlling Linea-Series speakers



### 3. The Linea Live Systems

**From more precise speech delivery to full-on live music, Fohhn® Linea Live guarantees the very best sound quality.**

Linea Live is a perfect combination of Linea LX-100 or LX-150 mini line array speakers and active subwoofers manufactured by Fohhn. The DSP-controlled active subs from the established Xperience-Series / X-Series incorporate presets that are specially configured for the LX-100 and LX-150 speakers. Linea Live combines the outstanding directional characteristics and sound properties of a line array system with the warm, deep bass sound of an active subwoofer system.

Perfektes Zubehör und intelligente Fernsteuerungsmöglichkeiten runden das System ab.

Sie eignen sich hervorragend für Sprach- und Musikübertragung in Hallen, Clubs, Kirchen, Museen etc. Auch in schwieriger Akustik mit langen Nachhallzeiten garantieren die Linea Live Systeme eine hervorragende Sprachverständlichkeit und ein ausgewogenes, homogenes Klangbild.

#### Fohhn® Linea Live Basic and Power Systems

The Basic System comprises two Linea LX tops combined with a DSP-controlled active sub. Power Systems also include a passive sub, which can easily be connected to the active one. Active subs are fitted with the latest Class D digital amplifiers. Fohhn's integrated 2-stage DSP technology allows an optimal adjustment between sub and tops, guaranteeing a balanced sound at any speaker volume level. Fohhn's own specially developed factory presets are designed to save time in the most diverse sound reinforcement situations. Using the integrated audio tools (EQ, compressor, etc.), individual settings can also be created and saved as presets.

##### Linea Live I (basic system):

2x Linea LX-100 + 1x X-Sub XS-10

##### Linea Live I (power system):

2x Linea LX-100 + 1x X-Sub XS-10 + 1x X-Sub XSP-10

##### Linea Live II (basic system):

2x Linea LX-100 + 1x X-Sub XS-20

##### Linea Live II (power system):

2x Linea LX-100 + 1x X-Sub XS-20 + 1x X-Sub XSP-2

Linea Live systems consist of a DSP-controlled active subwoofer that powers Linea Tops and an additional passive subwoofer. The systems are built using state-of-the-art DSP technology and can be operated remotely.

##### \* Excellent musical sound and outstanding dynamics

Dynamic sound in all frequency ranges.

##### \* Extremely even sound – perfect from front to back

Pleasant volume in the direct vicinity, crystal clear speech intelligibility at a distance. A warm sound that fills the room. Also ideal for dinner and gala events.

##### \* Attractive in appearance, elegant design

Linea Live fits perfectly into any architectural environment.

##### \* Plug & Play

Integrated amplifiers and DSPs with specially configured presets. An active sub can operate up to 4 Linea LX systems.

##### \* Enjoy sound without interference

Amazing feedback rejection. Complex microphone configurations pose no problem.

##### \* Easy to transport and quick to set up

Extremely compact dimensions and low weight. All LX systems and active subs are equipped with state-of-the-art, lightweight neodymium speaker technology.

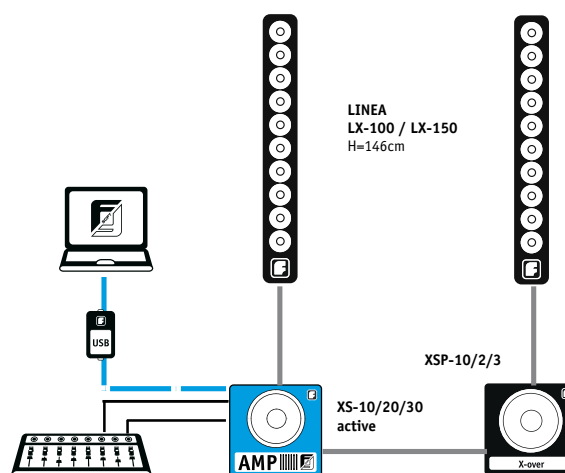

## Remote control and network ability of Fohhn devices with integrated DSP

### FR-10

remote control wall panel designed for the remote operation of Fohhn devices with integrated DSP.



#### Description

The FR-10 is a wall mount remote control module designed for the remote operation of Fohhn DSP amplifiers, DSP controllers and active Fohhn speakers systems. The FR-10 is extremely easy to operate because the controls are so well arranged. It is virtually impossible for the end customer to make operating errors because the only operating elements are the 8 labelled buttons.

#### Easy handling

Control up to 32 Fohhn devices individually with this stylish FR-10 wall panel. 8 programmable buttons can be configured to control the overall volume of a system, the volume in different zones or presets for different room effects, for example. The system also has a special function that confirms whether all commands have been executed successfully. The buttons indicate this by changing red or green shortly after they are pressed. For example, if a device is not switched on, the button changes red to indicate that a command could not be executed. This additional monitoring function ultimately contributes to the overall operating reliability of your system. The wall panel is easy to configure using a standard computer with intuitive Fohhn-Net Remote software installed.

#### Connections

Two terminal strips (paralleled). Alternative connection via standard 4-wire telephone cable.

#### Applications

The FR-10 is ideal for training rooms, hotels, churches, halls, restaurants or any venue where a simple, efficient system is required to control your audio equipment from a central location. The FR-10 is also ideal for projects where complex media control systems are not viable or inappropriate, but the user wishes to control the speaker system centrally.

### FR-20

19" remote control unit can be controlled via conventional external buttons or switches.



#### Description

The FR-20 can be controlled via conventional external buttons or switches (e.g. Jung, Vitra, etc.) or switching contacts (e.g. media control system). Buttons and switches may come in the form of a wall installation module or an individually manufactured control panel, for example.

Presets stored in the connected Fohhn DSP devices are activated simultaneously and settings for different scenarios such as speech, music, empty room, full room, etc are loaded when the buttons/switches are pressed. You can also adjust the volume quickly and easily in 1 dB increments using the FR-20. A maximum of 31 Fohhn devices connected to the network can be activated simultaneously at the press of a single button.

#### Integration in a media control system

The FR-20 allows the convenient integration of all DSP-controlled Fohhn devices into media control systems (e.g. AMX, Crestron) by means of 8 switching contacts or RS-485 interface.

#### Integration in a EIB bus technology

##### One building, one concept, one system.

Fohhn systems equipped with a FR-20 distribution switch comply with the „European installation bus technology“ standard, including all operating comforts.

#### Applications

The FR-20 is ideal for training rooms, hotels, churches, halls, restaurants, clubs, bars and many other venues.

For simple, reliable remote operation of your audio system without having to install complex, expensive media control systems.



## Accessories for LX-100

### WAL-1

pair of L-brackets for Linea LX-100/150



### WAT-08k

Wall bracket short for Linea LX-100/150

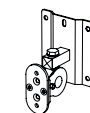

### WAT-08

Wall bracket for Linea LX-100/150

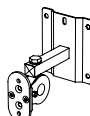

### WAT-12

Wall bracket for Linea LX-100/150

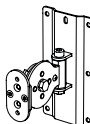

### SA-6

Pivot reducing flange, 36mm dia. with 2x M6 screw for Linea LX-100/150 with external teeth lock washers

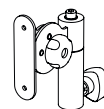

### SA-7

Special bracket for traverse mounting e.g. with optional Clamp LC-50 and TV-spigot with M10 female thread.

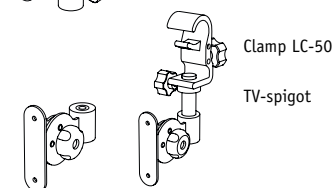

### EB-06

Ring stud DIN 580, zinc, for safety M6 thread



### Carrying bag

Carrying bag for Linea LX-100, padded



### Free Stand II

Designer stand with heavy round steel base with rubber feet for maximum stability obscured cable guide in the stand and round base. Wt: 14 kg, H: 1200 mm, base-diameter: 360 mm. Round base: black or white, stand tube: matt black. Appropriate for LX-100/150

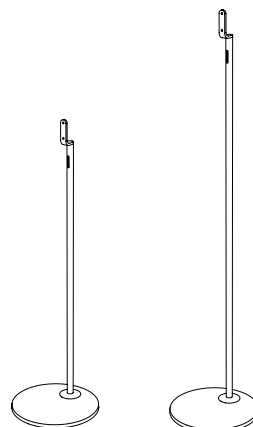

### Free Stand III

Designer stand with heavy round steel base with rubber feet for maximum stability obscured cable guide in the stand and round base. Wt: 14 kg, H: 1600 mm, base-diameter: 360 mm. Round base: black or white, stand tube: matt black. Appropriate for LX-100/150



Front view

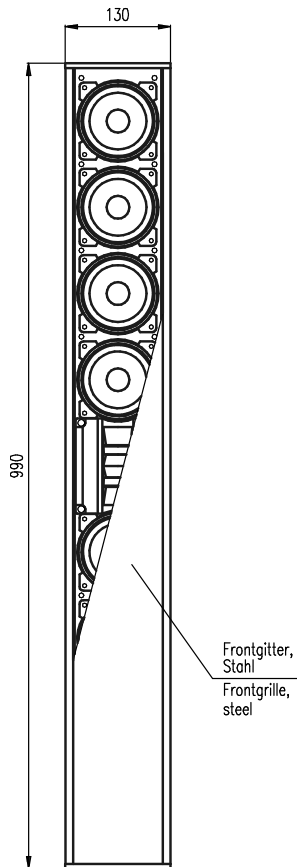

Side view

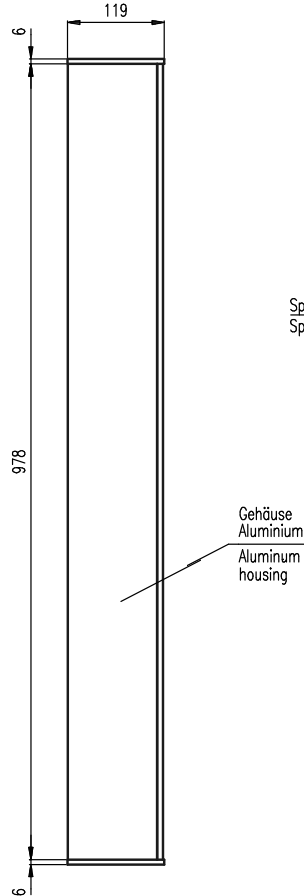

Rear view

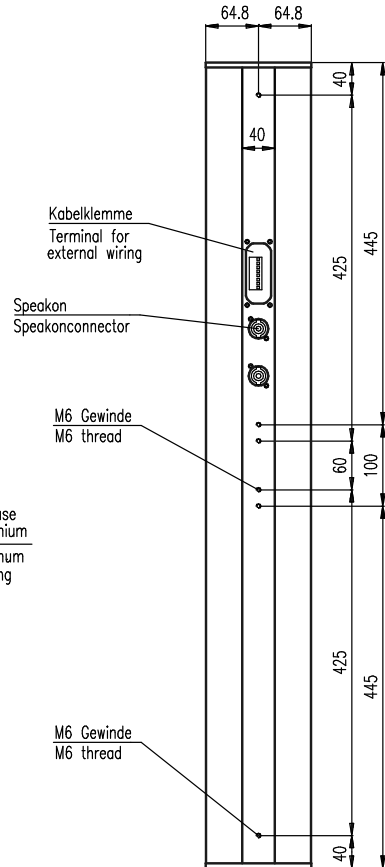

Top View

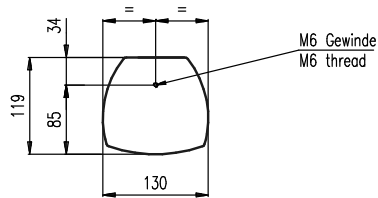

Bottom view

**WAL-1**

**Wall mount**

**Side view**

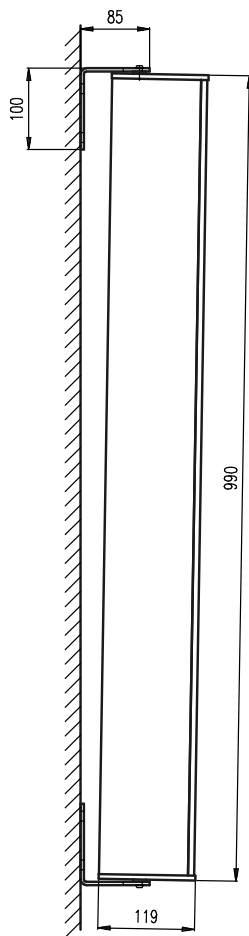

**Rear view**

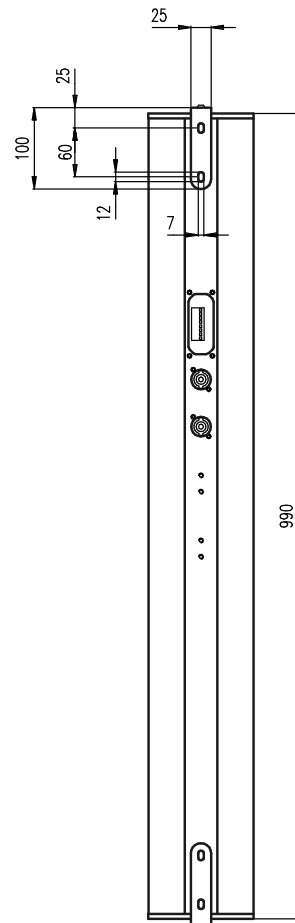

**Top View**

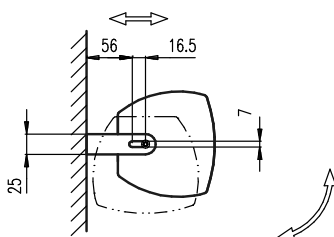



**WAT-08k**

**Wall mount**

**Side view**

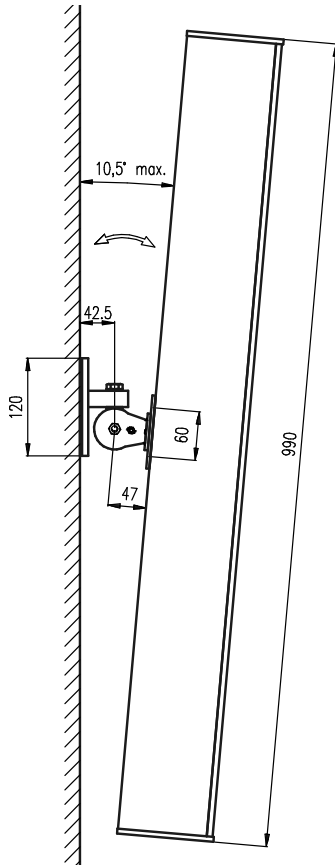

**Rear view**

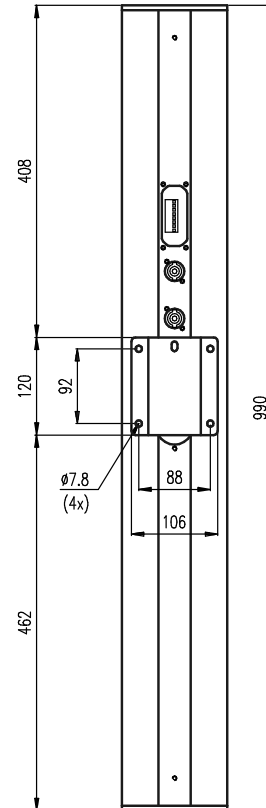

**Top View**

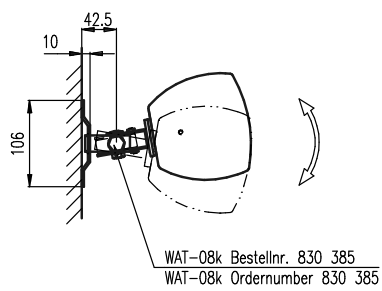

**WAT-08**

**Wall mount**

**Side view**

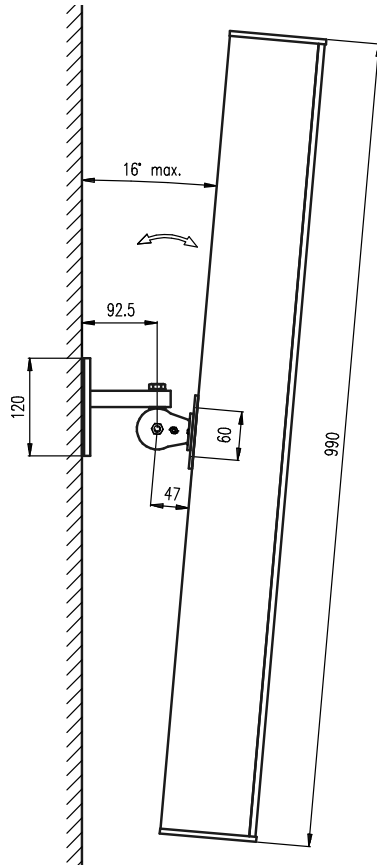

**Rear view**

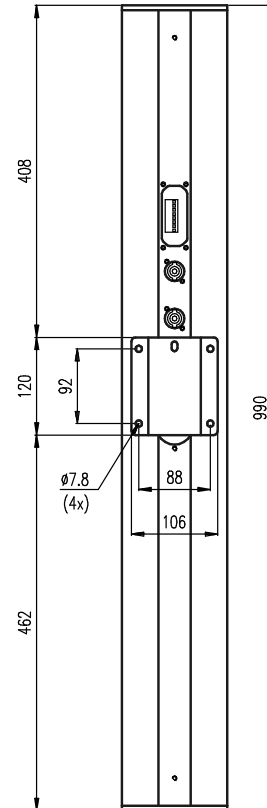

**Top View**

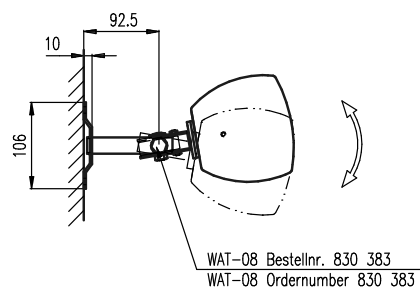

Wall mount

Side view

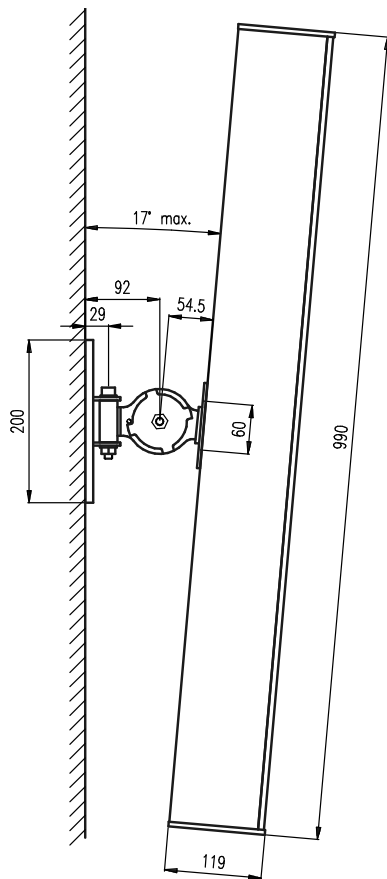

Rear view

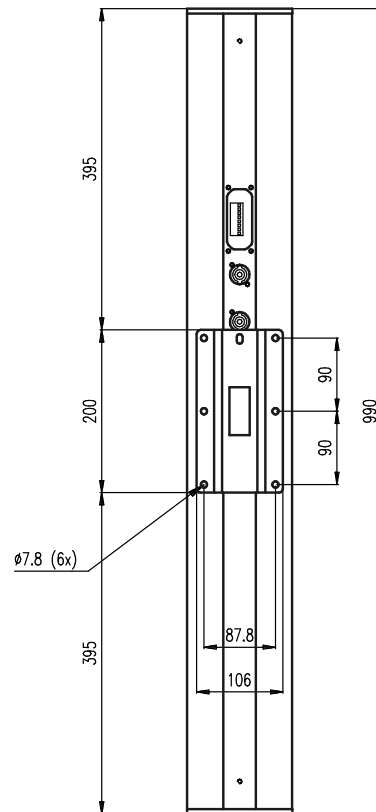

Top View

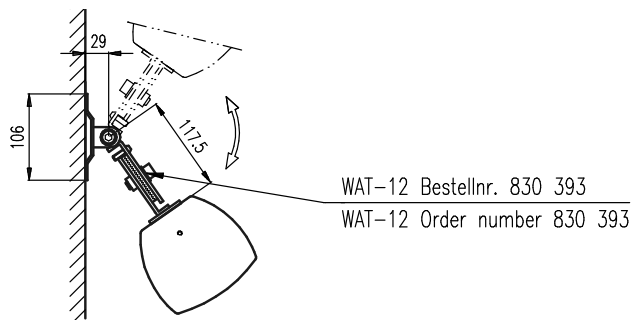

Stand mount

Side view

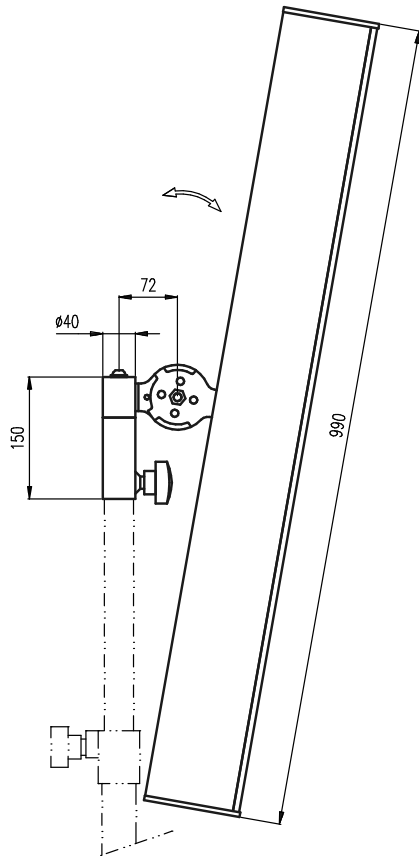

Rear view

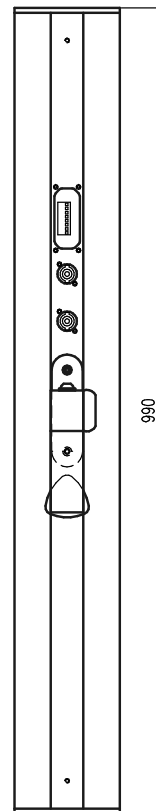

Top View

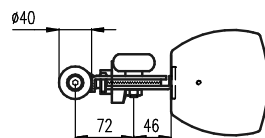

Flying applications

Side view

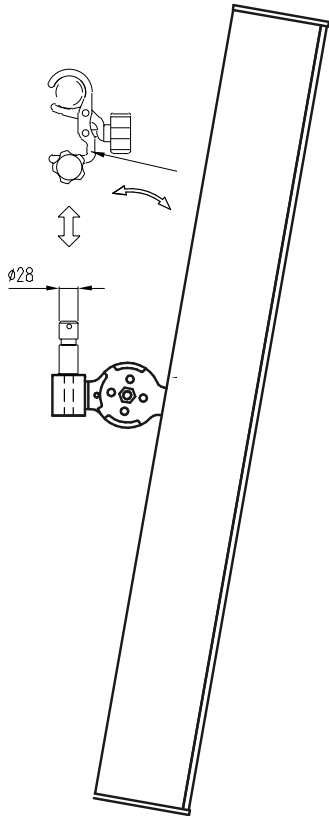

Rear view

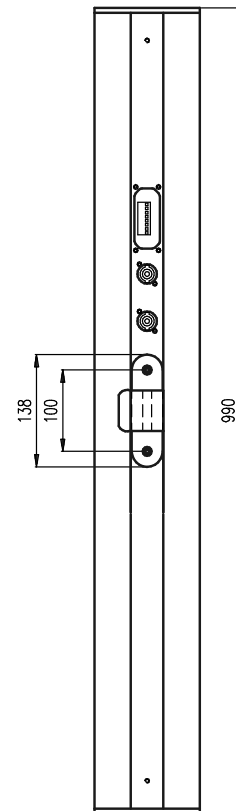

Top View

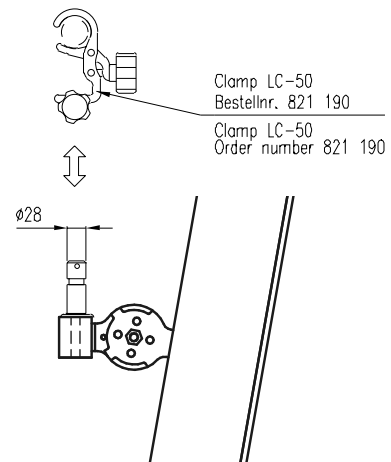
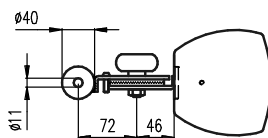

## Tender specifications

---

### Highly resilient passive 2-way line source speaker system in weatherproof aluminium enclosure

Highly resilient passive 2-way line source speaker system in aluminium enclosure, equipped with eight 4" high-performance line array speakers and one 1" compression driver with advanced HF Waveguide system. Because of the application of neodymium chassis and an aluminium enclosure, the speaker remains light with only 7 kg.

Perfectly suited for dynamic music transmissions in rooms with demanding acoustics, long reverberation times and challenging architecture. The Linea LX-100 can be used both in mobile and fixed installations. The speaker is temporarily able to work under 1600 W and generates acoustic pressure of maximal 126 dB. In a frequency range of 65 Hz to 20 kHz, the speaker has a precise and minimal-phase dispersion of 140° x 25° (h x v). Weatherproof, light aluminium enclosure with rounded sides, black or white powder coating. Optional available in all RAL-colours. For the protection of the speaker chassis and the electronics, the enclosure is equipped with a ball impact resistant, extremely sound-permeable front grille, which is made of powder-coated steel and equipped with a moisture- and dust repellent acoustic foam. The premium and complex crossover with an integrated electronic tweeter protection guarantees highest quality and operational reliability. Eight pieces M6 thread applications in ground, upper and rear side are integrated to the admission of system brackets. The loudspeaker system is optionally available with an integrated 100V-transformer up to 60 W. Connections: two Neutrik NL4 speakon plug jacks and screw- and pluggable 8-pin Phoenix terminal strip, which is very easy to assemble. All contacts exist twice, to connect very easy and safe to the next speaker. Specific brackets to assemble the system on ceilings and walls are optionally available. Simulation data CAAD for ULYSSES and EASE are available.

#### electro-acoustical features

acoustic design	line source speaker system, 2-way
components	8x 4" impreg. speaker membranes and 1x 1" on Waveguide, (fully neodymium)
power rating (nominal)	400 W
power rating (program)	800 W
power rating (peak)	1600 W
sensitivity	94 dB
maximum SPL	126 dB
frequency range	65 Hz – 20 kHz
nominal dispersion (h x v)	140° x 25°
nominal impedance	8 ohms

#### features

enclosure	Aluminium design
protection grille	ball impact resistant metal, powder coating
suspension points	8x M6 thread
connectors	2x Neutrik NL4 Speakon, 8-pin Phoenix terminal
standard colours	black or white powder coating
front design	metal grille in enclosure colour
dimensions (W x H x D)	130 x 990 x 120 mm
weight	7 kg

#### optional features

integrated 100 V-transformer	60/30/15 W
optional colours	all RAL-colours
weather resistance	standard

**CAAD simulation data** ULYSSES, EASE

**Make** Fohhn Audio AG  
**Type** LX-100

# SOUNDS PERFECT. IS PERFECT.

Fohhn audio systems. The ultimate all-round audio experience.



■ German quality  
■ engineered and made  
■ by Fohhn®

## Fohhn Audio AG

Hohes Gestade 3-7  
72622 Nürtingen  
Germany  
Tel. +49 7022 93323-0  
Fax +49 7022 93324-0  
[www.fohhn.com](http://www.fohhn.com)  
[info@fohhn.com](mailto:info@fohhn.com)