

Tri Motion

User Guide V1.0



VOID

©2018 Void Acoustics Research Ltd.

Version 1.0

This user guide is subject to change without notice.
For the latest online version, visit: www.voidacoustics.com

Void Acoustics and the Void logo are registered trademarks of Void Acoustics Research Ltd. in the United Kingdom, USA and other countries; all other Void trademarks are the property of Void Acoustics Research Ltd.

Contents

1	Safety and regulations	4	8	Service	34
1.1	Important safety instructions	4	8.1	Return authorisation	34
1.2	Limitations	4	8.2	Shipping and packing considerations	34
1.3	EC declaration of conformity	4			
1.4	WEEE directive	4	9	Appendix	35
2	Limited warranty	5			
3	Unpacking and checking	6			
4	About	7			
4.1	Welcome	7			
4.2	Tri Motion overview	7			
4.3	Key features	7			
4.4	Tri Motion specifications	8			
4.5	Dimensions	9			
5	Cabling and wiring	10			
5.1	Electrical safety	10			
5.2	Cable considerations for fixed installations	10			
5.3	Tri Motion wiring diagram	11			
5.4	Bias V3/V9 speakON™ wiring	12			
5.5	Bias VQ speakON™ wiring	12			
5.6	Bias D1/Q2 Phoenix wiring	13			
5.7	Bias Q5 speakON™ wiring	13			
6	System design	14			
6.1	Tri Motion to bass alignment	14			
6.2	System design principles	14			
6.3	Loudspeaker placement and positioning	16			
7	Mounting	19			
7.1	Installation safety	19			
7.2	Mounting the U bracket	20			
7.3	Tri Motion ground stacking	21			
7.4	Wall mounting	23			
7.5	Ceiling mounting	26			
7.6	Truss mounting	28			
7.7	Ceiling pole mounting	30			
7.8	Pole mounting on U bracket	32			

1 Safety and regulations

1.1 Important safety instructions



The lightning flash with an arrowhead symbol within an equilateral triangle is intended to alert the user to the presence of uninsulated "dangerous voltage" within the product's enclosure that may be of sufficient magnitude to constitute a risk of electric shock to persons.



The exclamation point within an equilateral triangle is intended to alert the user of the presence of important operating and maintenance (servicing) instructions in the literature accompanying the appliance.

Safety instructions - read this first

1. Read these instructions.
2. Keep these instructions.
3. Heed all warnings.
4. Follow all instructions.
5. Do not use this apparatus near water.
6. Clean only with a dry cloth.
7. Do not block any ventilation openings. Install in accordance with the manufacturer's instructions.
8. Do not install near any heat source such as radiators, heat registers, stoves, or other such apparatus that produce heat.
9. Do not defeat the safety purpose of the grounding-type plug. A grounding type plug has two blades and a third grounding prong. The third prong is provided for your safety. If the provided plug does not fit into your outlet, consult an electrician for replacement of the obsolete outlet.
10. Protect power cords from being walked on or pinched particularly at plugs, convenience receptacles, and the point where they exit the apparatus.
11. Only use attachments and accessories specified by Void Acoustics.
12. Only use with the cart, stand, tripod, bracket, or table specified by the manufacturer, or sold with the apparatus. When a cart is used, use caution when moving the cart/apparatus combination to avoid injury from tip-over.
13. Unplug the apparatus during lightning storms or when unused for long periods of time.
14. Refer all servicing to qualified service personnel. Servicing is required when the apparatus has been damaged in any way, such as when the power-supply cord or plug is damaged, liquid has been spilled or objects have fallen into the apparatus, the apparatus has been exposed to rain or moisture, does not operate normally, or has been dropped.
15. Since the mains power supply cord attachment plug is used to disconnect the device, the plug should always be easily accessible.
16. Void loudspeakers can produce sound levels capable of causing permanent hearing damage from prolonged exposure. The higher the sound level, the less exposure needed to cause such damage. Avoid prolonged exposure to the high sound levels from the loudspeaker.

1.2 Limitations

This guide is provided to help familiarise the user with the loudspeaker system and its accessories. It is not intended to provide comprehensive electrical, fire, mechanical and noise training and is not a substitute for industry-approved training. Nor does this guide absolve the user of their obligation to comply with all relevant safety legislation and codes of practice.

While every care has been taken in creating this guide, safety is user-dependent and Void Acoustics Research Ltd cannot guarantee complete safety whenever the system is rigged and operated.

1.3 EC declaration of conformity

Manufacturer:

Void Acoustics Research Ltd,
Unit 15 Dawkins Road Ind Est,
Poole, Dorset,
BH15 4JY,
United Kingdom.



We declare the under our sole responsibility the following product models: Air Motion, Tri Motion, Airten, Air Stream, Air Vantage, Air 8

are intended to be used as loudspeakers and are in conformity with the following EC Directives, including all amendments, and with national legislation implementing these directives:

- BS EN 60065:2002
- BS EN 55103-1/-2

March 2016

Alex Skan
Technical Director

1.4 WEEE directive

If the time arises to throw away your product, please recycle all the components possible.



This symbol indicates that when the end-user wishes to discard this product, it must be sent to separate collection facilities for recovery and recycling. By separating this product from other household-type waste, the volume of waste sent to incinerators or land-fills will be reduced and natural resources will thus be conserved.

The Waste Electrical and Electronic Equipment Directive (WEEE Directive) aims to minimise the impact of electrical and electronic goods on the environment. Void Acoustics Research Ltd complies with the Directive 2002/96/EC and 2003/108/EC of the European Parliament on waste electrical and electronic equipment (WEEE) in order to reduce the amount of WEEE that is being disposed of in land-fill sites. All of our products are marked with the WEEE symbol; this indicates that this product must NOT be disposed of with other waste. Instead it is the user's responsibility to dispose of their waste electrical and electronic equipment by handing it over to an approved reprocessor, or by returning it to Void Acoustics Research Ltd for reprocessing. For more information about where you can send your waste equipment for recycling, please contact Void Acoustics Research Ltd or one of your local distributors.

2 Limited warranty

Limited warranty

The warranty

For a period of three (3) years from the date of delivery to the original purchaser (as shown on the original invoice or sales receipt; a copy of this may be required as proof of warranty dates), Void Acoustics Research Ltd (hereinafter "Void") warrants to the Original Owner (person or company who originally purchased the product brand new from either Void or a Void Authorised Dealer/Distributor) of each new Air Series product (provided it was purchased at an Authorised Void Dealer) that it is free of defects in materials and workmanship and that each product will meet or exceed all factory published specifications for each respective model. Void agrees to repair or replace (at its discretion) all defective parts at no charge for labour or materials; subject to following provisions:

Warranty violations

Void shall take no responsibility for repair or replacement as specified under this warranty, if the damaged product has been subject to misuse, accident, neglect or failure to comply with normal maintenance procedures; or if the serial number has been defaced, altered or removed. Nor will Void accept responsibility for, or resulting from, improper alterations or unauthorised parts or repairs. This warranty does not cover any damage to speakers or any other consequential damage resulting from breach of any written or implied warranty.

Void warranty provisions

Void will remedy any defect, regardless of the reason for failure (except as excluded) by repair, or replacement. Void will remedy the defect and ship the product within a reasonable time after receipt of the defective product at a Void Authorised Service Centre.

To obtain warranty service

If a Void product requires service, the Owner must contact Void or an Authorised Void Service Centre to receive an R.A.N. (Return Authorisation Number) and instructions on how to return the product to the Void Authorised Service Centre, or to Void.

Void (or its Authorised Service Centre) will initiate corrective repairs upon receipt of the returned product. Please save the original carton and all the packing materials in case shipping is required. All products being returned to the factory or service centre for repairs must be shipped prepaid.

If the repairs made by Void or the Void Authorised Service Centre are not satisfactory, the Owner is instructed to give written notice to Void. If the defect or malfunction remains after a reasonable number of attempts by Void to remedy the defect or malfunction, the Original Owner shall then have the option to elect either a refund or replacement of said Void product free of charge. The refund shall be an amount equal to but not greater than the actual purchase price, not including any taxes, interest, insurance, closing costs and other finance charges (minus reasonable depreciation on the product). If a refund is necessary, the Original Owner must make the defective or malfunctioning product available to Void free and clear of all liens or other restrictions.

Equipment modifications

Technical and design specifications are subject to change without notice.

Void reserves the right to modify or change equipment (in whole or part) at any time prior to delivery thereof, in order to include therein electrical or mechanical improvements deemed appropriate by Void, but without incurring any liability to modify or change any equipment previously delivered, or to supply new equipment in accordance with any earlier specifications.

Disclaimer of consequential and incidental damages

You, the Original Owner, are not entitled to recover from Void any incidental damages resulting from any defect in the Void product.

This includes any damage to another product or products resulting from such a defect.

Warranty alterations

No person has the authority to enlarge, amend, or modify this Warranty. This Warranty is not extended by the length of time which the Original Owner is deprived of the use of product. Repairs and replacement parts provided pursuant to the Warranty shall carry only the non-expired portion of the Warranty.

This Statement of Warranty supersedes all others contained in this user guide.

3 Unpacking and checking

All Void Acoustics products are carefully manufactured and thoroughly tested before being despatched. Your dealer will ensure that your Void products are in pristine condition before being forwarded to you but mistakes and accidents can happen.

Before signing for your delivery:

- Inspect your shipment for any signs of contamination, abuse or transit damage as soon as you receive it
- Check your Void Acoustics delivery fully against your order
- If your shipment is incomplete or any of its contents are found to be damaged; inform the shipping company and inform your dealer.

Tri Motion loudspeakers are heavy (47.1 kg/103.8 lbs) and require a minimum two people to lift.

- Undo the four butterfly catches on the transport case then remove the lid making sure the lid is clear before moving sideways
- If you need to place the Tri Motion on a flat surface ensure you use a lint free product to protect the finish
- To remove from the transport case, each person should hold the Tri Motion on each side, with one hand on the edge of the horn flare, and the other supporting the weight of the drivers to the rear, as shown in figure 3.1
- When removing the Tri Motion take care not to damage the lower tray of the transport case.

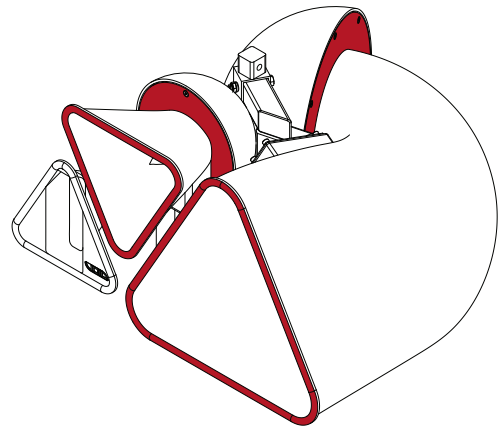

Figure 3.1: Safe handling positions diagram (as indicated in red)

Keep the original packaging in case you need to return a product for service later.

See section 2 for warranty conditions and see section 8 if your product needs servicing.

4 About

4.1 Welcome

Many thanks for purchasing this Void Acoustics Tri Motion. We truly appreciate your support. At Void, we design, manufacture and distribute advanced professional audio systems for the installed and live sound market sectors. Like all Void products, our highly skilled and experienced engineers have successfully combined pioneering technologies with ground-breaking design aesthetics, to bring you superior sound quality and visual innovation. In buying this product, you are now part of the Void family and we hope using it brings you years of satisfaction. This guide will help you both use this product safely and ensure it performs to its full capability.

4.2 Tri Motion overview

The aesthetically striking Tri Motion pushes sonic and creative frontiers, providing extraordinary efficiency and controlled dispersion, perfect for larger venues requiring cutting-edge performance.

4.3 Key Features

- Triangular format waveguides for enhanced pattern control
- Low resonance fibreglass composite construction
- Integrated flying and mounting system
- Optional floor stand or flying bracket
- Internal electronic HF protection

4 About

4.4 Tri Motion specifications

Frequency response	120 Hz - 20 kHz ± 3 dB
Efficiency ¹	LF: 107 dB 1W/1m, HMF: 110 dB 1W/1m
Crossover points	LF: 120 Hz and 500 Hz, HMF: 500 Hz - Passive 1.4 kHz
Nominal impedance	LF: 8 Ω , HMF: 8 Ω
Power handling ²	LF: 700 W AES, HMF: 250 W AES
Maximum output ³	135 dB cont, 138 dB peak
Driver configuration	1 x 15" LF, 1 x 8" MF, 1 x 1.5" HF compression driver
Dispersion	90°H x 60°V
Protection	Internal electronic control
Connectors	2 x 4-pole speakON™ NL4
Height	515 mm (20.3")
Width	810 mm (31.9")
Depth	720 mm (28.3")
Weight	47.1 kg (103.8 lbs)
Enclosure	Fibreglass composite
Rigging	Internal fly/mounting system. Can be used with stand or bracket
Colour	Custom colours available upon request

¹ Measured in half space ² AES2 - 1984 compliant ³ Calculated

4 About

4.5 Tri Motion dimensions

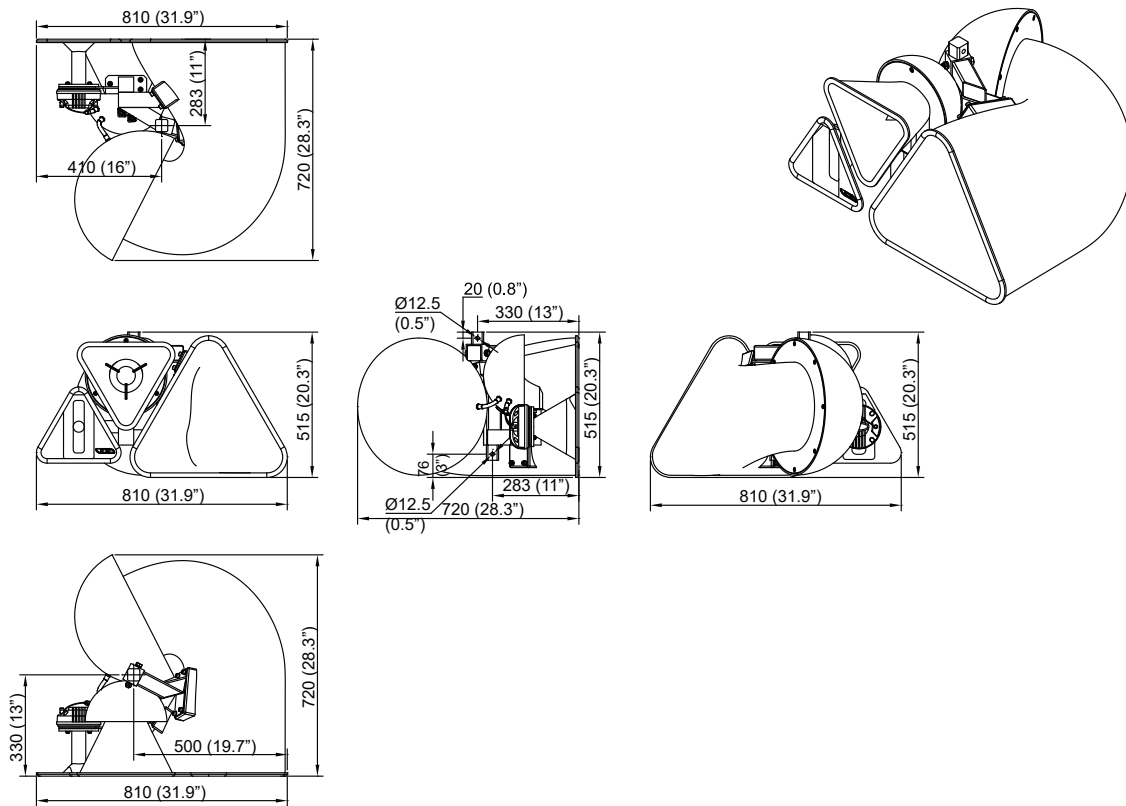

Figure 4.1: Dimensions (left-handed version)

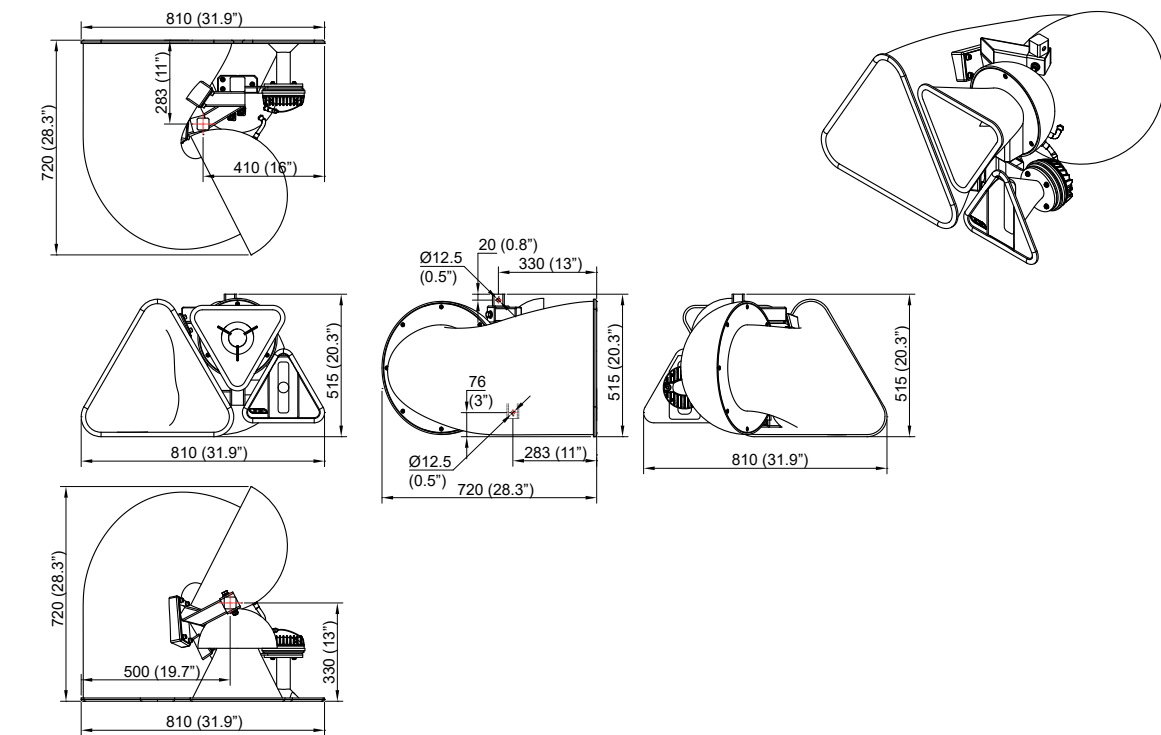

Figure 4.1: Dimensions (right-handed version)

5 Cabling and wiring

5.1 Electrical safety



To avoid electrical hazards please note the following:

- Do not access the inside of any electrical equipment. Refer servicing to Void-approved service agents

5.2 Cable considerations for fixed installations

We recommend specifying installation-grade Low Smoke Zero Halogen (LSZH) cables for permanent installations. Cables for permanent installations should be compliant with the following standards:

- IEC 60332.1 Fire retardancy of a single cable
- IEC 60332.3C Fire retardancy of bunched cables
- IEC 60754.1 Amount of Halogen Gas Emissions
- IEC 60754.2 Degree of acidity of released gases
- IEC 61034.2 Measurement of smoke density

Tri Motion loudspeakers are 3-way, bi-amplified. They require two amplifier channels to drive them via 4-core speakON™ NL4 cables. We suggest using the following maximum copper cable lengths to keep level losses below 0.6 dB.

Metric mm ²	Imperial AWG	8 Ω load	4 Ω load	2 Ω load
2.50 mm ²	13 AWG	36 m	18 m	9 m
4.00 mm ²	11 AWG	60 m	30 m	15 m

5 Cabling and wiring

5.3 Tri Motion wiring diagram

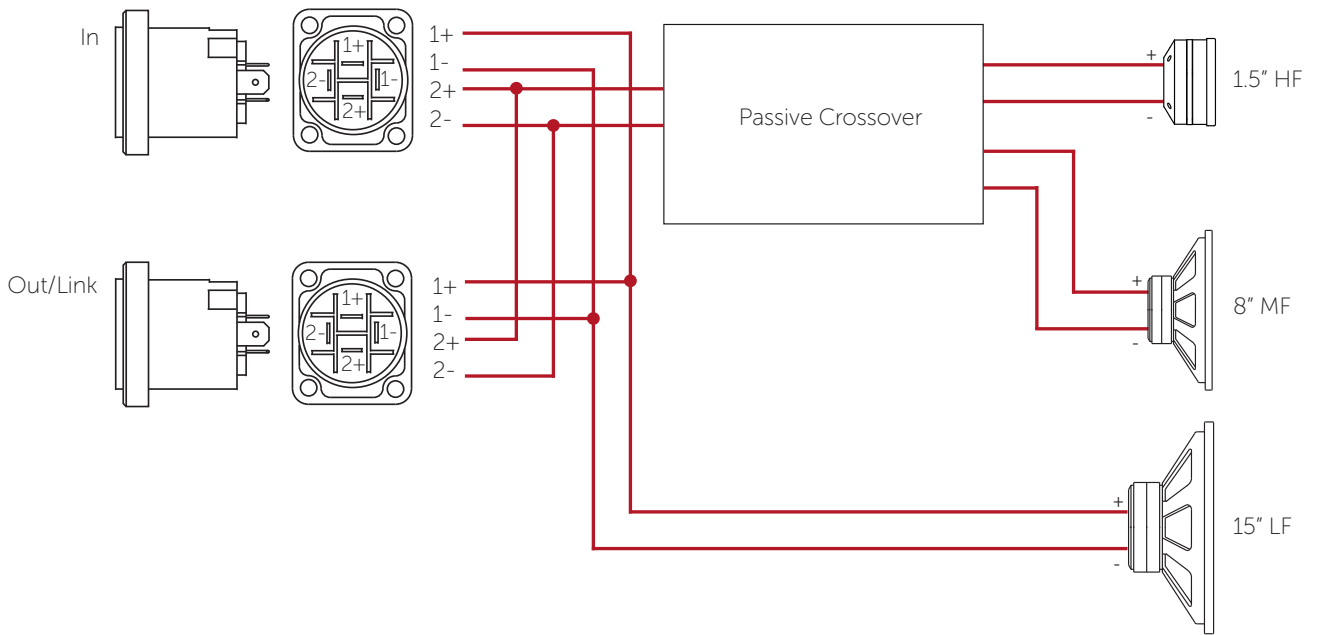

Figure 5.1: Tri Motion wiring diagram

	speakON™ pins 1+/1-	speakON™ pins 2+/2-
In	LF (15")	MHF (8" + 1.5")
Out	LF link	MHF link

5 Cabling and wiring

5.4 Bias V3/V9 speakON™ wiring

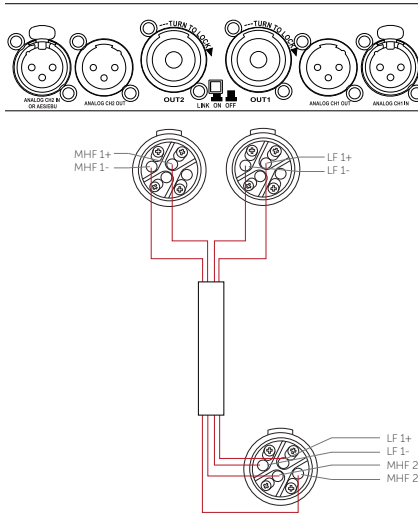

Figure 5.2: Bias V3

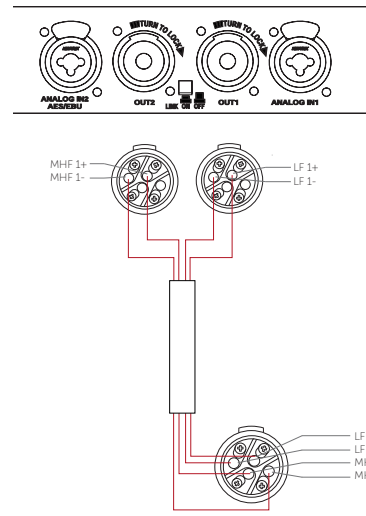

Figure 5.3: Bias V9

Bias V3/V9	Output 1	Output 2
Output	LF (15")	MHF (8"+1.5")
Max output	4 (2 Ω load to amplifier)	4 (2 Ω load to amplifier)

5.5 Bias VQ speakON™ wiring

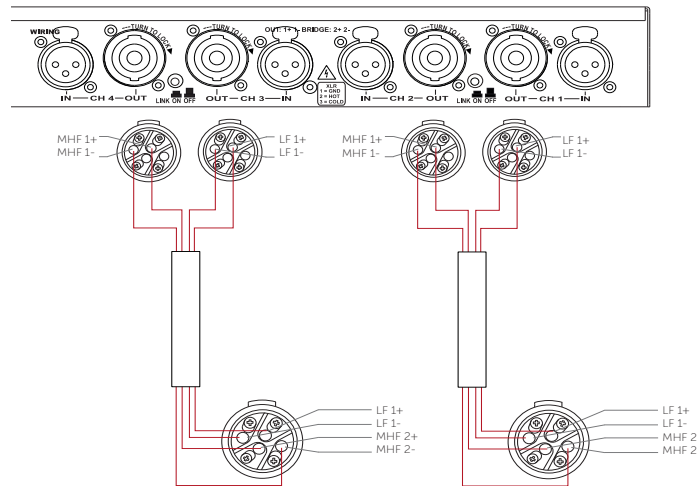

Figure 5.5: Bias VQ

Bias VQ	Output 1	Output 2	Output 3	Output 4
Output	Left LF (15")	Left MHF (8"+1.5")	Right LF (15")	Right MHF (8" 1.5")
Max quantity per channel	2 (4 Ω load to amplifier)	2 (4 Ω load to amplifier)	2 (4 Ω load to amplifier)	2 (4 Ω load to amplifier)

5 Cabling and wiring

5.6 Bias D1/Q2 phoenix wiring

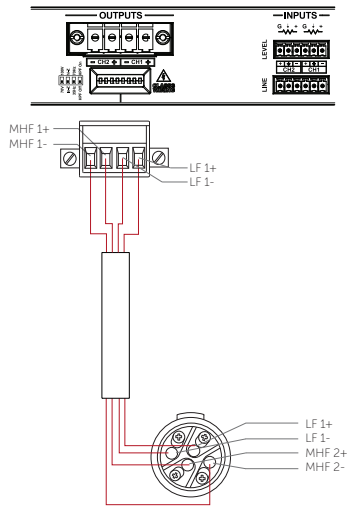

Figure 5.5: Bias D1

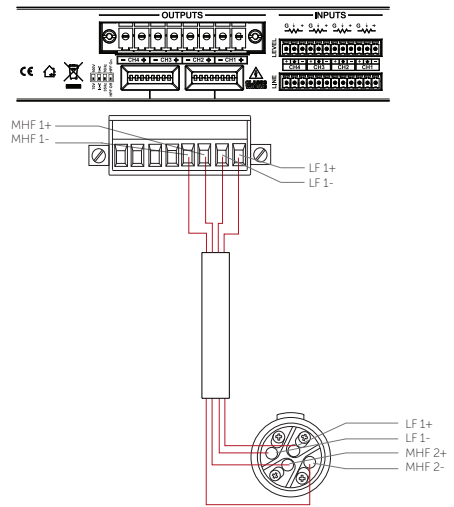

Figure 5.6: Bias Q2

Bias D1/Q2	Output 1	Output 2
Output	LF (12")	MHF (8"+1.5")
Max parallel units	4 (2 Ω load to amplifier)*	4 (2 Ω load to amplifier)*

*Recommended max parallel units 2 (4 Ω load to amplifier) due to the power rating of the amplifier.

5.7 Bias Q5 speakON™ wiring

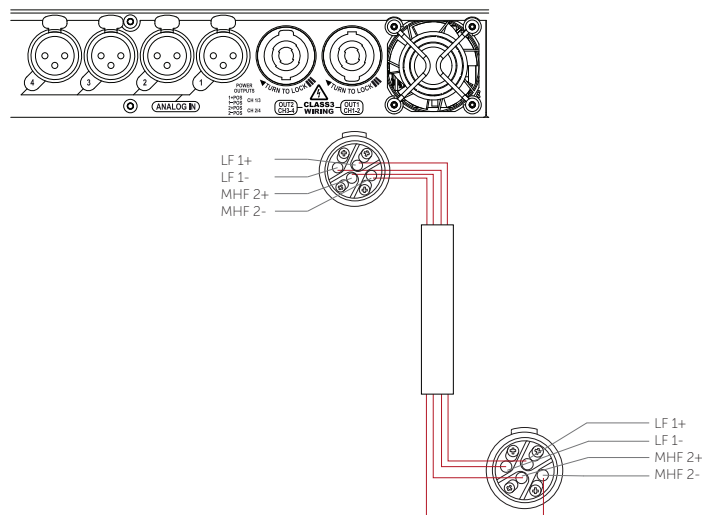

Figure 5.7: Bias Q5

Bias Q5	Output 1	Output 2
Output	LF (12")	MHF (8"+1.5")
Max quantity per channel	2 (4 Ω load to amplifier)	2 (4 Ω load to amplifier)

6 System design

6.1 Tri Motion bass alignment

Loudspeaker/ amplifier combinations	Tri Motion		Stasys 118		Tri Motion		Stasys 218		Tri Motion		Stasys X/Xair	
	Gain	Delay (ms)	Gain	Delay (ms)	Gain	Delay (ms)	Gain	Delay (ms)	Gain	Delay (ms)	Gain	Delay (ms)
Bias VQ	-4	0			n/a	n/a			n/a	n/a		
Bias VQ			0	1.4			n/a	n/a			n/a	n/a
Bias VQ	0	2.3			0*	2.3			-3*	4.8		
Bias V3/V9/ D1/Q2/Q5			0	0			0	0			0	0
Bias V3/V9/ D1/Q2/Q5	-4	0			-4*	0			-4*	1.5		
Bias V3/V9/ D1/Q2/Q5			0	1.4			0	1.4			0	0

All polarities positive unless otherwise stated.

*This is for 1:1 ratio of sub to top, if adding more subs, increase the gain on the mid-high element by 4-5 dB for each additional sub.

6.2 System design principles

Tri Motions are supplied in Left and Right-handed pairs. The recommended configuration is to position the MF and HF horns on the outside, as this gives a wider stereo image.



Figure 6.1: Tri Motion arrangement

6 System design

For temporary installation, a popular system configuration is two stacks consisting of a Stasys Xair on end, with an Tri Motion and ground-stack board. This raises the Tri Motion to a useful height above the audience, and the sensitivity of the Stasys Xair matches the Tri Motion well. Suitable for events of up to 500 people.

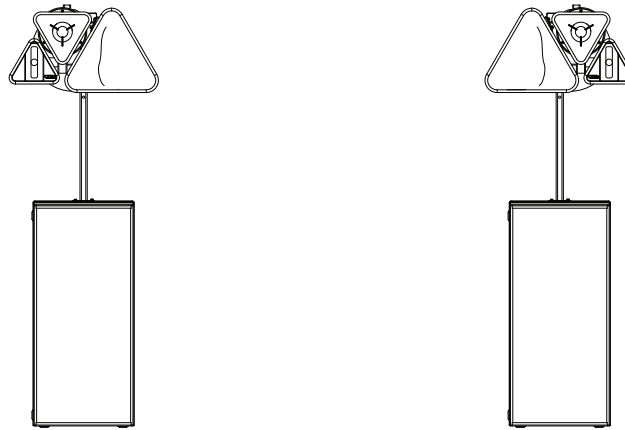

Figure 6.2: Tri Motion bass cabinet mounting

For permanent installation, it is recommended to fly Tri Motions for more even coverage. This also allows co-located subwoofers in a single block, increasing sensitivity and providing more consistent bass coverage.

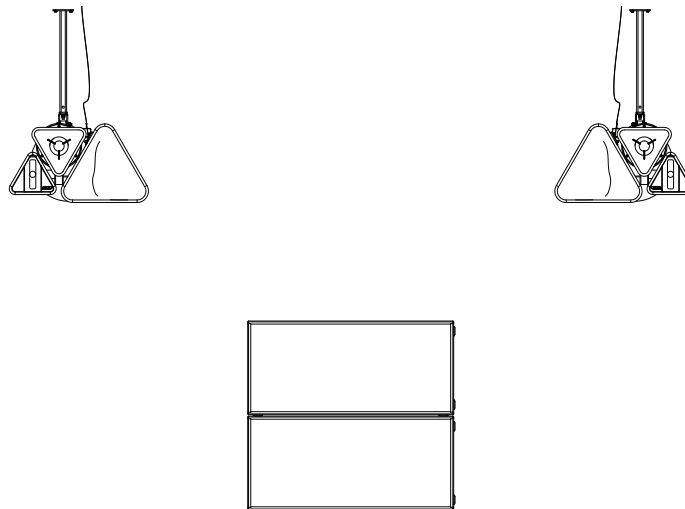

Figure 6.3: Tri Motion ceiling mounting

6 System design

6.3 Loudspeaker placement and positioning

When deploying Tri Motion it's important to consider the speakers vertical position to maximise coverage in the vertical axis. Horizontal loudspeaker dispersion figures dictate the coverage of the loudspeaker, left to right, to the -3 dB points. The same can be said for the vertical dispersion figure, but when applied to a listening area, this figure dictates the audience area coverage front to back.

Vertical dispersion is often overlooked or not assessed properly resulting in inefficiently deployed loudspeaker systems that require more fill loudspeakers than is necessary to achieve required coverage. Following are some basic guidelines when considering the vertical position of your Tri Motion loudspeaker.

With optimum vertical positioning and aiming applied the loudspeaker system can be used at maximum efficiency. With a point source loudspeaker in this configuration the speaker is placed 2m-3m from the ground, aimed half way, to two thirds of the way back of the audience area, as shown in figure 6.5. The applied aiming reduces unwanted reflections from the ceiling and directs the highest energy concentration to the audience area requiring it most.

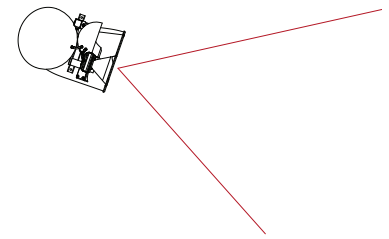

Figure 6.4a: Vertical dispersion

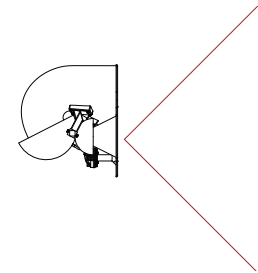

Figure 6.4b: Horizontal dispersion

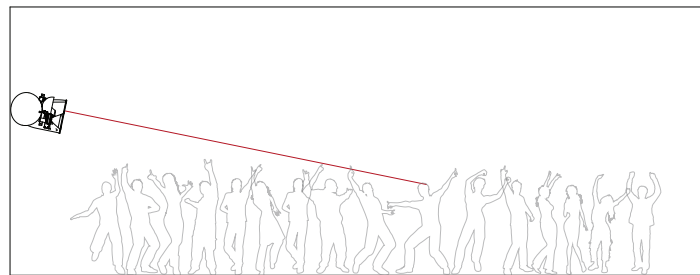

Figure 6.5: Correct loudspeaker placement



A multi point loudspeaker system in a club/bar environment can very pleasing for the listener however it's still important that the processes applied to previous examples are still implemented. In figure 6.6 you can see the loudspeakers have been positioned and aimed optimally. When deploying a multi point loudspeaker system extra consideration must be taken to counter unwanted room effects. Careful positioning and aiming of loudspeakers will minimise room effects whilst maintaining even coverage throughout the audience area.

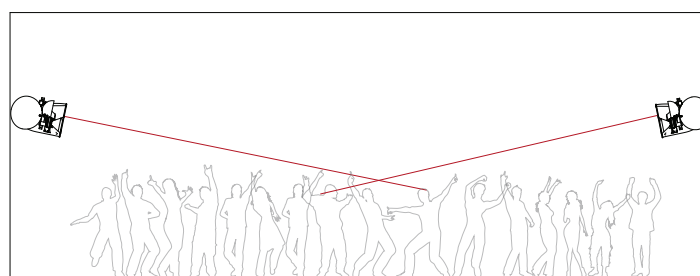

Figure 6.6: Multi point loudspeaker arrangement



6 System design

In the horizontal plane (figure 6.7) rotate the Tri Motion toward the audience area at an angle such that the centre line of the dispersion from each loudspeaker meets about two thirds of the way towards the rear of the audience area. This will help provide a wider coverage and result in more of the power being used usefully.

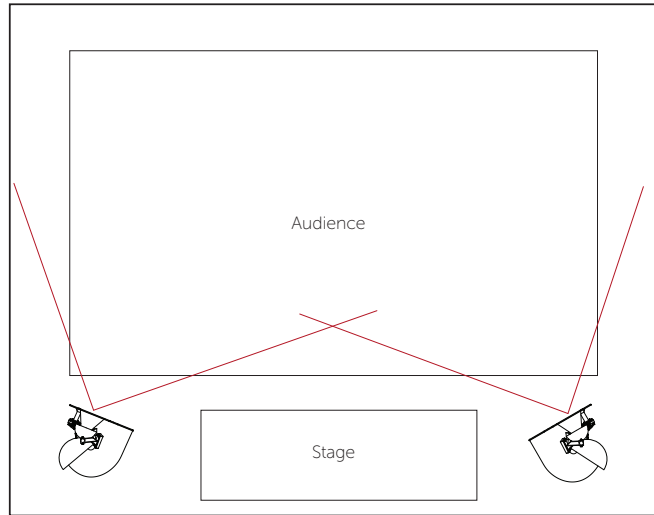

Figure 6.7: Correct horizontal dispersion

Avoid directing the Tri Motion straight forward. This will result in a proportion of the power being directed towards the walls, creating possible reflective issues, as well as causing a gap in coverage at the centre of the audience area.

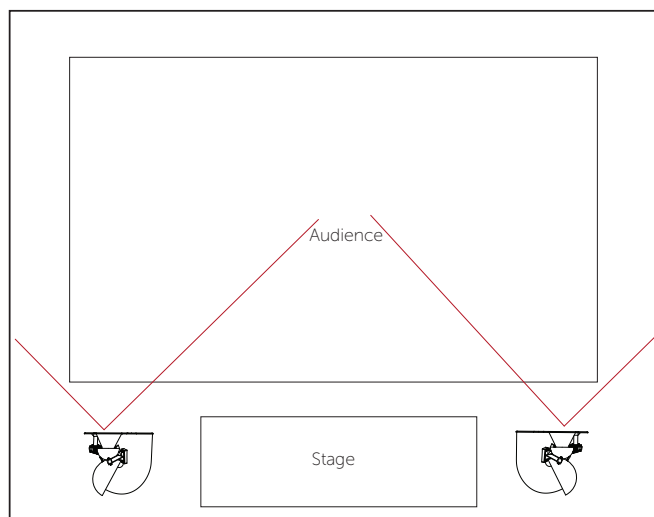

Figure 6.8: Incorrect horizontal dispersion

6 System design

In figure 6.9 the loudspeakers vertical positioning is too low for the audience area. Mid and high range frequencies will be absorbed by the first two rows of people resulting in poor coverage and potential acoustic issues from room reflections.



Figure 6.9: Incorrect loudspeaker placement

Figure 6.10 shows the loudspeaker vertical position is optimal for the audience area but the user hasn't applied an aiming angle. In this case a large portion of energy is directed at the ceiling that could result in reduced intelligibility and unwanted room acoustic characteristics. The shallow angle of attack will also induce refraction issues on a hot dance floor, leading to reduced HF penetration at mid and far distances, again reducing intelligibility and coherence. This is the most desirable position for the loudspeakers in this example.

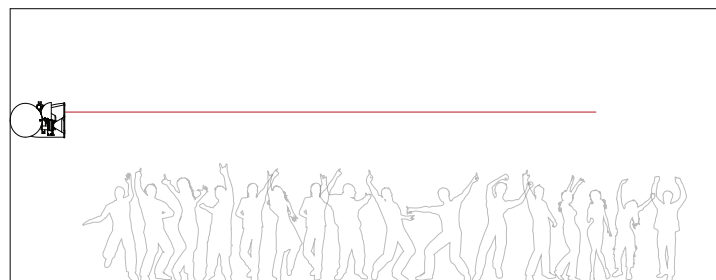

Figure 6.10: Incorrect loudspeaker placement

7 Mounting

Tools Required

- 19 mm ratchet spanner/wrench

7.1 Installation safety



To avoid mechanical hazards, please note the following:

- Safety regulations vary in different regions. Full compliance with those regulations must be your priority
- Rigging must only be undertaken by fully qualified and experienced riggers who understand local regulations
- This may include consulting a structural engineer before installation of wall brackets
- Remember that all personnel have a duty of care to themselves, to their assistants, to the venue staff and to the public
- Before lifting any part of the system above head height, check the whole rig for loose tools or other items that may fall and cause injury
- Do not use a telephone (even if hands-free) whilst rigging. Always concentrate fully on the rigging operation
- Do not rig equipment that is worn, damaged, corroded, mishandled or over-stressed in any way
- Use only Void-approved mounting equipment and accessories
- Secondary safeties should be provided in all instances where cabinets are flying or fixing overhead and should conform to local regulations

7.2 Mounting the U bracket

Parts required:

- Air series U bracket

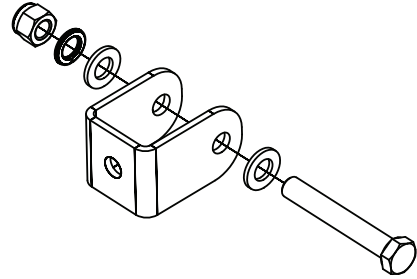

Figure 7.1: Air series U bracket

Step 1:

Lay a soft lint free rug clear of debris on the ground to avoid damage to the speaker. Place the Tri Motion with the horns down taking care to follow the safe handling in section 3. Insert the U bracket for the desired orientation.

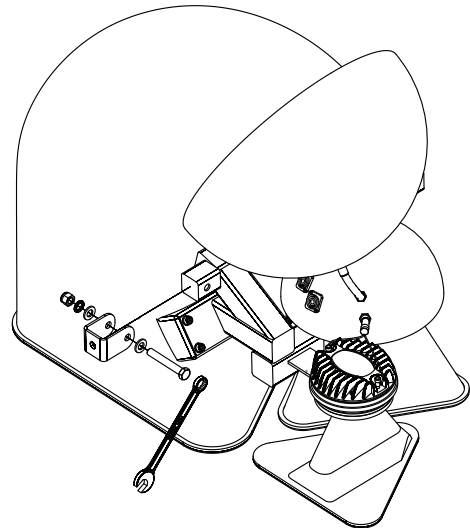

Figure 7.2: U bracket positioning



Step 2:

Note: The U bracket is threaded for the bolt on one side only. Insert the M12 x 70 mm bolt through the non-threaded side of the U bracket, then tighten the M8 nyloc nut.

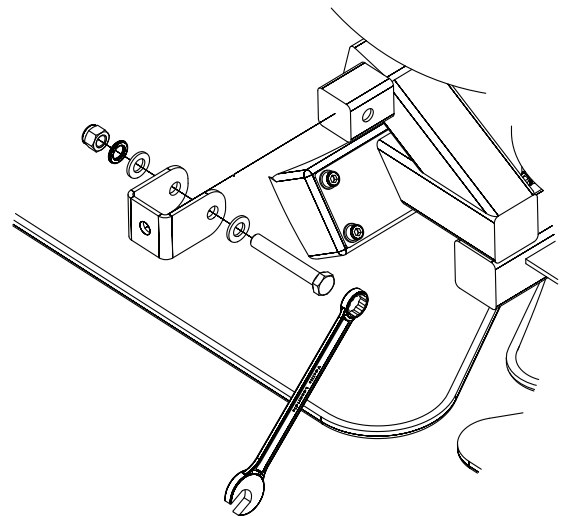

Figure 7.3: U bracket detail

7.3 Tri Motion ground stacking

Parts required:

- Stasys Xair/XV2
- Stasys 218 mounting board with bracket

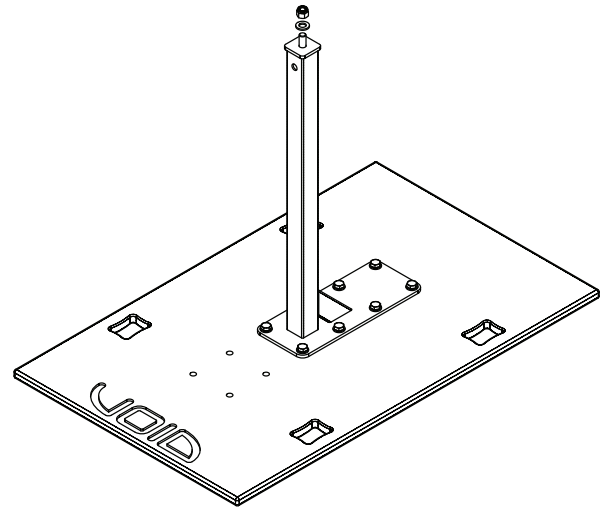

Figure 7.4: Stasys Xair/XV2 or Stasys 218 mounting board with bracket

Step 1:

Remove M12 Aerotight nut from stand using 19 mm ratchet spanner.

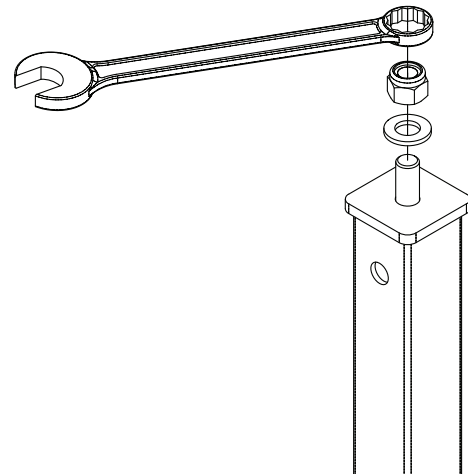

Figure 7.5: M12 Aerotight nut removal



Step 2:

Lift the Tri Motion with two people (with one hand on the edge of the horn flare and the other supporting the weight of the drivers at the rear) and position the mounting hole over the stand bolt. For safe handling locations see section 3.

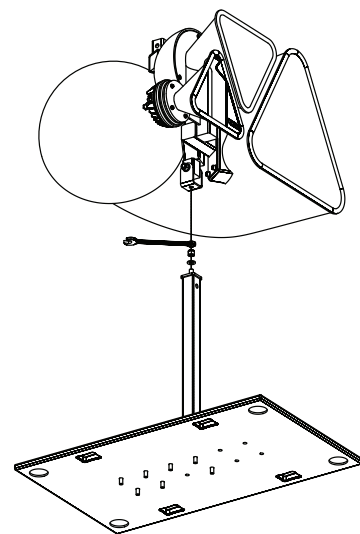

Figure 7.6: Air Motion mounting

7.3 Tri Motion ground stacking

Step 3:

Tighten the M12 Aerotight nut using a 19 mm ratchet spanner while another person supports the Tri Motion.

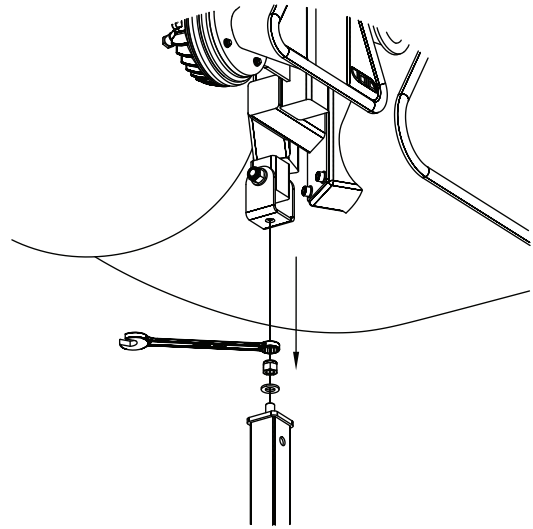

Figure 7.7: M12 Aerotight nut tightening

Step 4:

Confirm the Tri Motion is securely fastened to the stand, and lift the assembly onto the bass-cabinet with suitable equipment.



The assembly is heavy; be aware of the high centre of gravity! You will need to tilt the mounting board forward to place one hand under the board and get a secure grip on the hand hold. Then place your other hand on the horn-flare. Raise the assembly to the bass cabinet and slide until the feet drop into the feet pockets. If the bass cabinet is on an uneven surface, ensure that it is stabilised with wedges before mounting the Tri Motion.

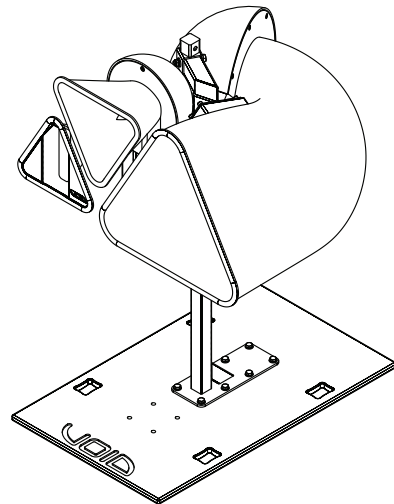

Figure 7.8: Tri motion on mounting board

Step 5:

Secure with a minimum of one 1 tonne SWL ratchet straps. Ensure the stand is secured from sliding or rotating and on a level surface.

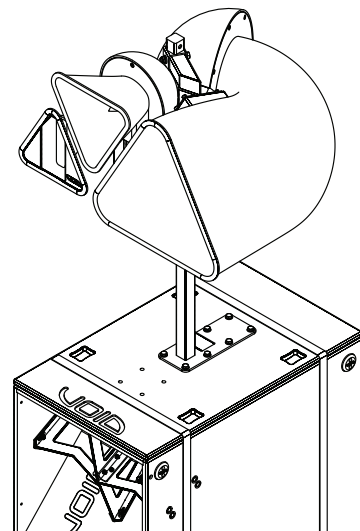

Figure 7.9: Tri Motion mounting

7.4 Wall mounting

Parts required:

- AMMB wall/ceiling mount
- 8 x wall fixing
- Multi bracket extension

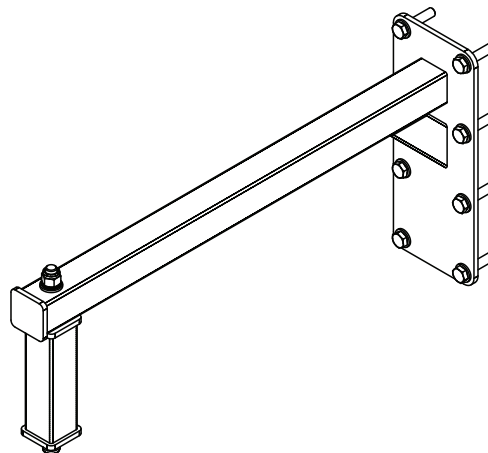

Figure 7.10: AMMB wall/ceiling bracket with extension piece

Step 1:

Begin by fixing the bracket to the wall and then fix the extension piece to the bracket with the M12 Aerotight nut using a 19 mm ratchet spanner.



All eight bolts must be fitted when securing the bracket to the wall. Take care when mounting the bracket to the wall, making sure to use the correct fixing and that the wall can take the load, for example do not attach the bracket to a stud wall.

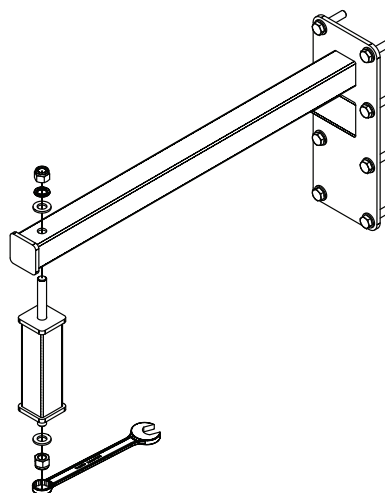

Figure 7.11: Extension piece assembly

Step 2:

Lift the Tri Motion into position making sure to hold by the safe lifting positions detailed in section 3.

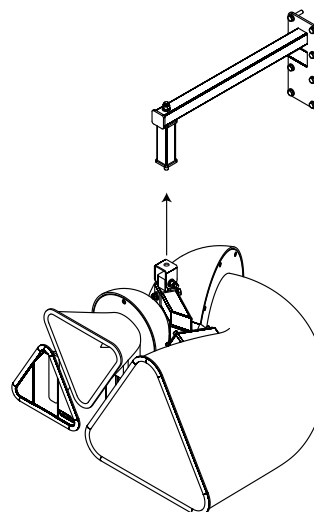

Figure 7.12: Tri Motion lifting

7.4 Wall mounting

Step 3:

Attach the U bracket to the extension piece with the M12 Aerotight nut using a 19 mm ratchet spanner.

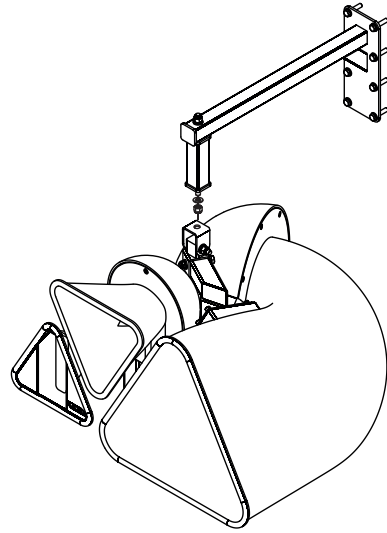

Figure 7.13: Tri Motion wall mount

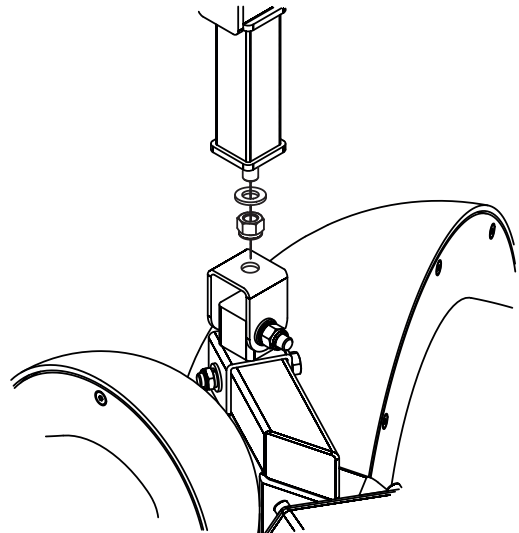

Figure 7.14: Tri Motion wall mount detail

Step 4:

With the lifting equipment still in place, attach the secondary bond safety wire (not supplied) to the central box section. The safety wire should be attached to a secondary fixing point, close to where the bracket is fixed to the wall.

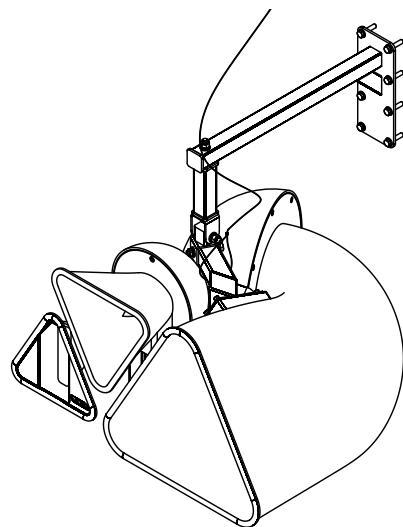

Figure 7.15: Safety wire attachment

7.4 Wall mounting



The safety wire must be rated to 47.1 kg (103.8 lbs) with a safety factor conforming to local regulations.

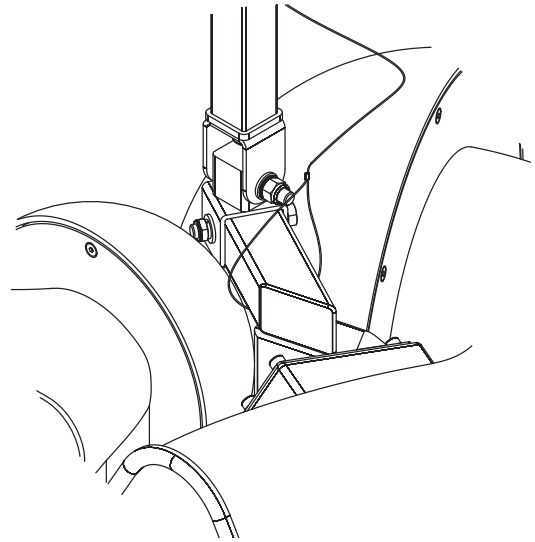

Figure 7.16: Safety wire attachment detail

7.5 Ceiling mounting

Parts required:

- AMMB wall/ceiling mount
- 8 x wall fixing

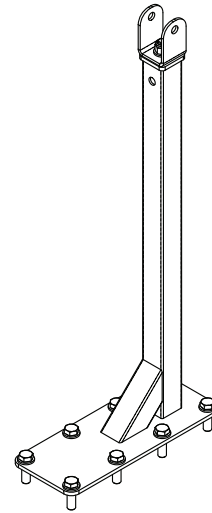

Figure 7.18: AMMB wall/ceiling bracket

Step 1:

Lift the Tri Motion into position making sure to hold it by the safe lifting positions detailed in section 3.



All eight bolts must be fitted when securing the bracket to the ceiling.

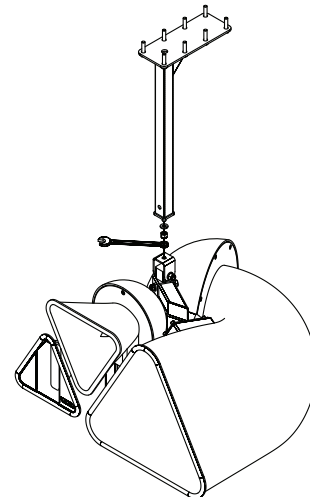

Figure 7.19: Tri motion ceiling mounting

Step 2:

Attach the Tri Motion the bracket with the M12 Aerotight nut using a 19 mm ratchet spanner.

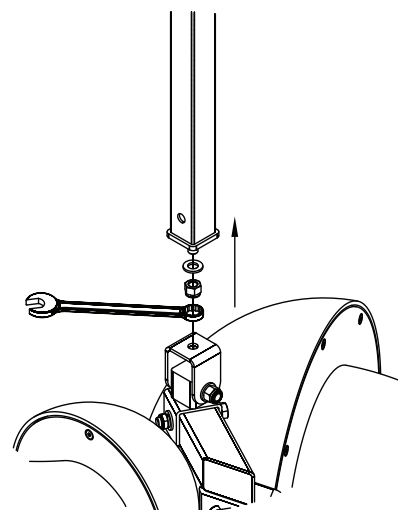

Figure 7.20: Tri motion ceiling mounting detail

7.5 Ceiling mounting

Step 4:

Attach the secondary bond (safety wire) to the central box section.

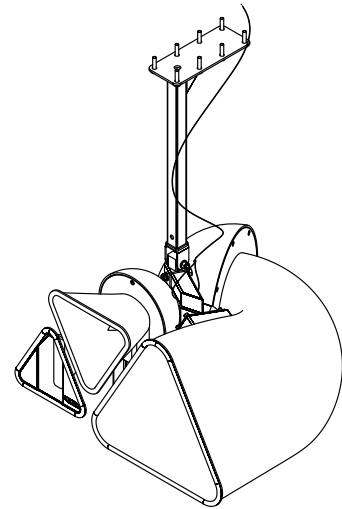

Figure 7.21: Safety wire attachment



The safety wire must be rated to 47.1 kg (103.8 lbs) with a safety factor conforming to local regulations.

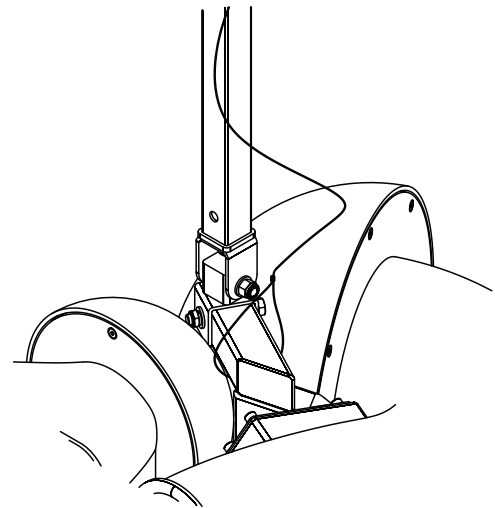

Figure 7.22: Safety wire detail

7.6 Truss mounting

Parts required:

- AMTB truss mount bracket (to be mounted on truss or 48 mm OD bar).

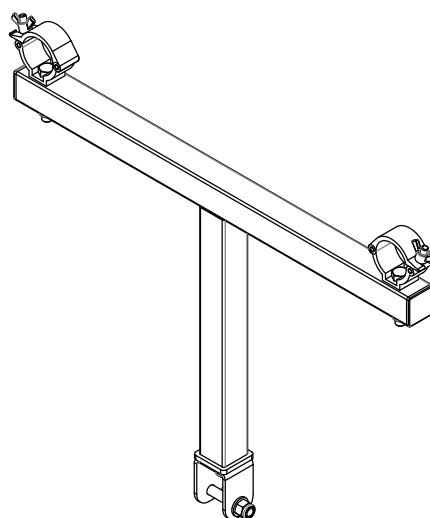

Figure 7.23: AMTB truss mount bracket

Step 1:

Remove the wing-nuts from the couplers and position the bracket in the desired location on the truss.

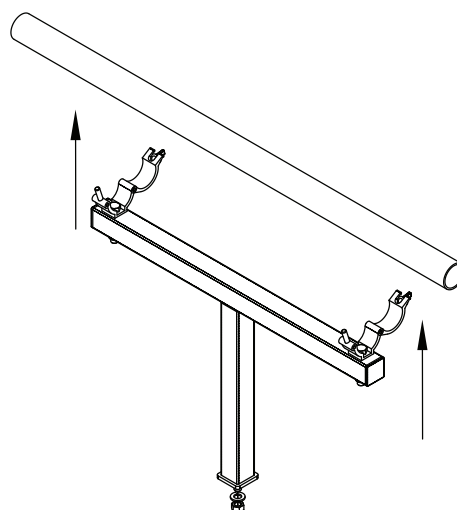

Figure 7.24: Truss bracket positioning

Step 2:

Tighten the wing-nuts on the couplers so that the bracket is securely fastened. Remove the M12 Aerotight nut using a 19 mm ratchet spanner.

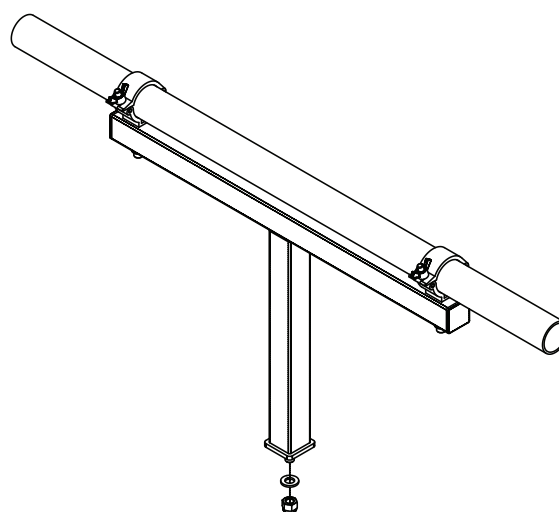

Figure 7.25: Truss bracket fixing

7.6 Truss mounting

Step 3:

Lift the Tri Motion into position making sure to hold it by the safe lifting positions detailed in section 3.

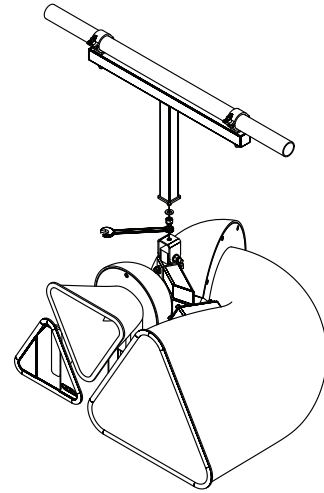

Figure 7.26: Tri Motion truss mount

Step 4:

Attach the Tri Motion the bracket with the M12 Aerotight nut using a 19 mm ratchet spanner.

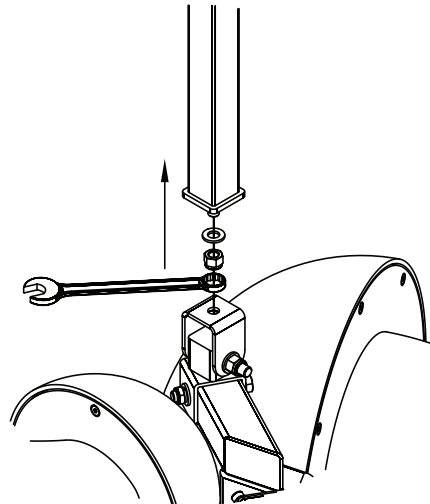

Figure 7.27: Tri Motion truss mount detail

Step 5:

Attach the secondary bond (safety wire) to the central box section.



The safety wire must be rated to 47.1 kg (103.8 lbs) with a safety factor conforming to local regulations.

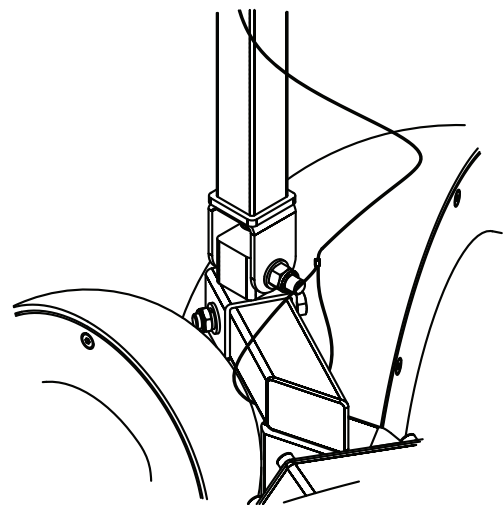

Figure 7.28: Safety wire attachment

7.7 Ceiling pole mounting

Parts required:

- Air series ceiling bracket



All eight bolts must be fitted when securing the bracket to the ceiling.

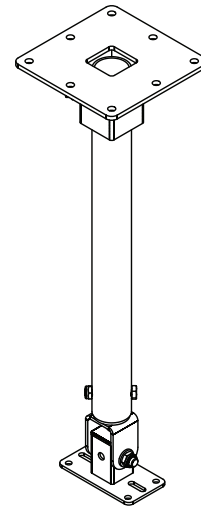

Figure 7.29: Air series ceiling bracket

Step 1:

Lift the Tri Motion into position making sure to hold it by the safe lifting positions detailed in section 3.

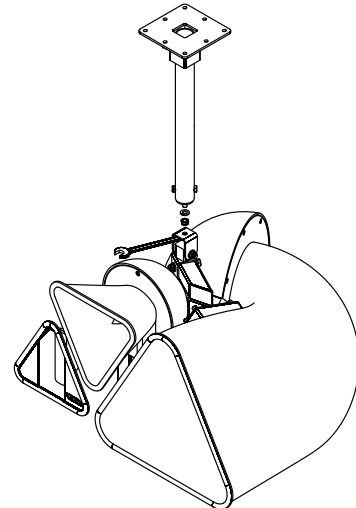

Figure 7.30: Tri Motion positioning

Step 2:

Attach the Tri Motion the bracket with the M12 Aerotight nut using a 19 mm ratchet spanner.

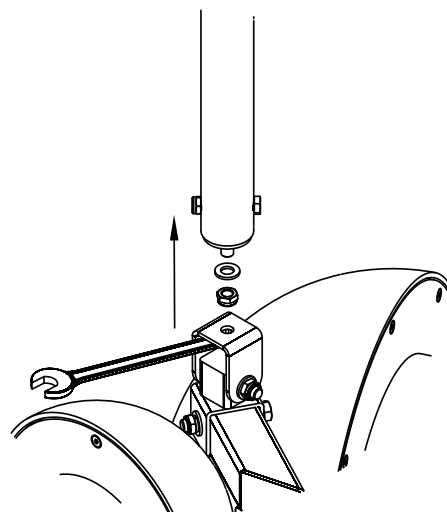

Figure 7.31: Attaching the Tri Motion

7.7 Ceiling pole mounting

Step 3:

Attach the secondary bond (safety wire) to the central box section.



The safety wire must be rated to 47.1 kg (103.8 lbs) with a safety factor conforming to local regulations.

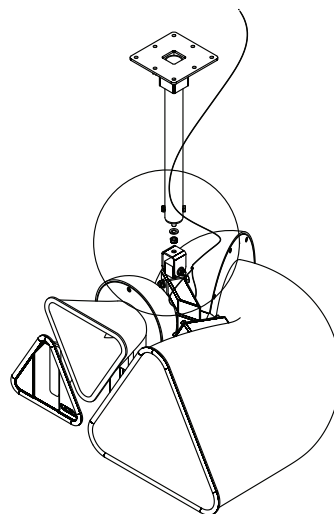

Figure 7.32: Safety wire attachment

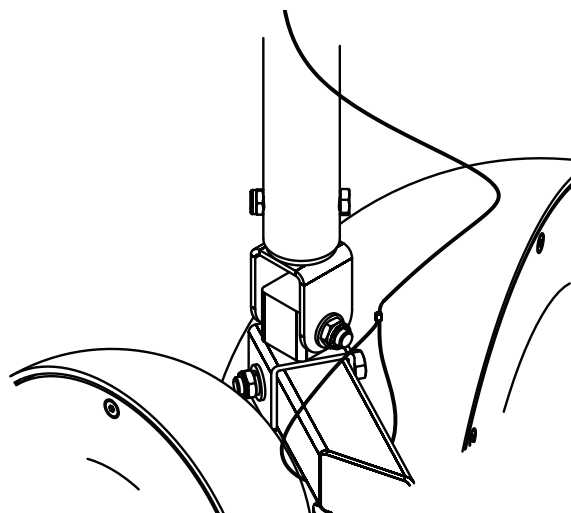

Figure 7.33: Safety wire detail

7.8 Pole mounting on U bracket

Parts required:

- Air series pole mount bracket

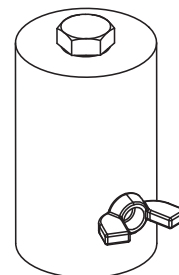

Figure 7.34: Air series pole mount bracket

Step 1:
Remove the M12 bolt from the pole mount bracket.

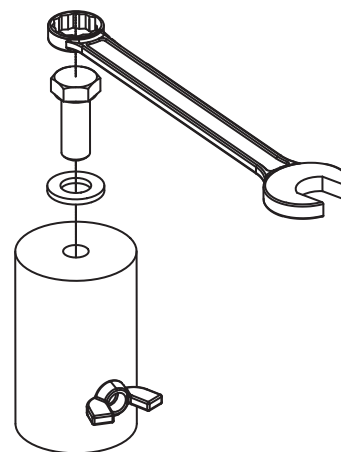

Figure 7.35: Pole mount bracket removal

Step 2:
Mount the pole mount bracket to the U bracket.

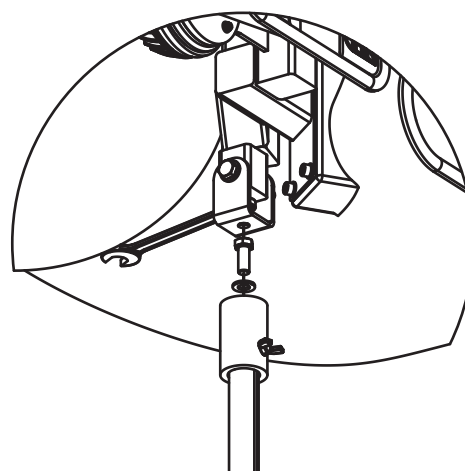

Figure 7.36: Mounting to the U bracket

7.8 Pole mounting on U bracket

Step 3:

Lift the Tri Motion loudspeaker into position taking care to follow the safe handling positions detailed in section 3.

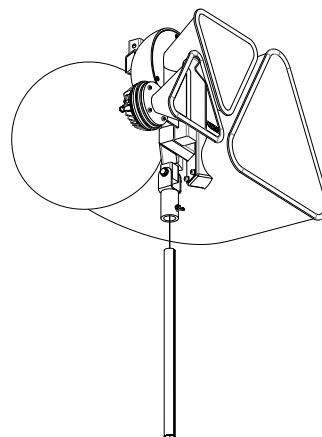

Figure 7.37: Positioning the loudspeaker

Step 4:

Adjust the loudspeaker into the desired position and then tighten the wing nut on the pole mount bracket.

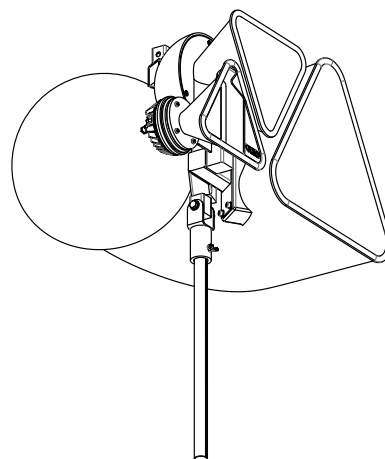

Figure 7.38: Adjusting the loudspeaker position

8 Service

Void Tri Motion loudspeakers should only be serviced by a fully trained technician.



No user serviceable parts inside. Refer servicing to your dealer.

8.1 Return authorisation

Before returning your faulty product for repair, please remember to get an R.A.N. (Return Authorisation Number) from the Void dealer who supplied the system to you. Your dealer will handle the necessary paperwork and repair. Failure to go through this return authorisation procedure could delay the repair of your product.

Note that your dealer will need to see a copy of your sales receipt as proof of purchase so please have this to hand when applying for return authorisation.

8.2 Shipping and packing considerations

- When sending a Void Tri Motion loudspeaker to an authorised service centre, please write a detailed description of the fault and list any other equipment used in conjunction with the faulty product
- Accessories will not be required. Do not send the instruction manual, cables or any other hardware unless your dealer asks you to
- Pack your unit in the original factory packaging if possible. Include a note of the fault description with the product. Do not send it separately
- Ensure safe transportation of your unit to the authorised service centre.

9 Appendix

The loudspeaker shall be an active three-way bi-amped system consisting of one high power 15" (380 mm) isometric triangular horn loaded low frequency (LF) transducer with a two way mid-high frequency section consisting of an 8" (200 mm) isometric triangular horn loaded mid-high frequency (MHF) transducer and one 1.5" (38.1 mm) diameter exit high frequency (HF) compression driver mounted on a waveguide. Both the LF and MHF transducers shall be enclosed in separate and independent moulded fibreglass composite cabinet with a smooth cellulose finish of any RAL colour.

The LF and MHF transducers shall be constructed on a cast aluminium frame, with a treated paper cone, 63.5 mm (4") for the LF and 50.8 mm (2") for the MHF voice coil, wound with copper wires on a high quality voice coil former, for high power handling and long term-reliability. The HF transducer shall project it's sound through a high precision wave-guide with a 200 mm (8") baffle to achieve pattern control and low distortion.

Performance specifications for a typical production unit shall be as follows: the usable on-axis bandwidth shall be 120 Hz to 20 kHz (± 3 dB) and shall average 60° directivity pattern on the vertical axis and 90° on the horizontal one (-6 dB down from on-axis level) from 1 kHz to 12 kHz. Maximum SPL shall be 138 dB peak measured at 1 m using IEC268-5 pink noise. Crossover points shall be at 500 Hz and 1.4 kHz using 3rd order filters (18 dB per octave). The system shall be powered by its own dedicated power amplification module with DSP management. The wiring connection shall be via two Neutrik speakON™ NL4 (one for input and one for loop-out to another speaker), to allow for pre-wiring of the connector before installation.

The enclosures shall be bolted onto a powder coated steel frame using no less than four M8 bolts per horn. This frame aligns the horns in the correct acoustic space to achieve constant directivity across the loudspeaker system's entire dispersion. The frame will incorporate mounting holes for a U bracket fixture for attaching to ceiling, wall and ground stack mounting brackets. The external dimensions of the enclosures and frame shall be (W) 810 mm x (H) 515 mm x (D) 720 mm (31.9" x 20.3" x 28.3"). Weight shall be 47.1 kg (103.8 lbs).

The loudspeaker shall be the Void Acoustics Tri Motion.

North America

Void Acoustics North America
503-854-7134
sales.usa@voidacoustics.com

Head Office

Void Acoustics Research Ltd
Unit 15 Dawkins Road Industrial Estate
Poole
Dorset
BH15 4JY
England

+44 (0) 1202 666 006
info@voidacoustics.com

Registered in England & Wales No. 07533536

www.voidacoustics.com

