

Venu 210i V2

User Guide V1.0



VOID

©2019 Void Acoustics Research Ltd.

Version 1.0

This user guide is subject to change without notice.
For the latest online version, visit: www.voidacoustics.com

Void Acoustics and the Void logo are registered trademarks of Void Acoustics Research Ltd. in the United Kingdom, USA and other countries; all other Void trademarks are the property of Void Acoustics Research Ltd.

Contents

1	Safety and regulations	4
1.1	Important safety instructions	4
1.2	Limitations	4
1.3	EC declaration of conformity	4
1.4	WEEE directive	4
2	Limited warranty	5
3	Unpacking and Checking	6
4	About	7
4.1	Welcome	7
4.2	Venu 210i V2 overview	7
4.3	Key features	7
4.4	Venu 210i V2 specifications	8
4.5	Dimensions	9
5	Cabling and wiring	10
5.1	Electrical safety	10
5.2	Cable considerations for fixed installations	10
5.3	Venu 210i V2 wiring	11
5.4	Input connectors	12
5.5	Output connectors	12
6	Venu 210i DSP	13
6.1	Components	13
6.2	Factory presets	14
6.3	Selecting your presets	14
6.4	LED chart	14
6.5	Software	15
6.6	Processing architecture	16
6.7	Internal signal path polarity	17
7	System design	18
7.1	System design principles	18
7.2	High frequency loudspeaker placement and positioning	19
7.3	Bass alignment - delay times	22
8	Service	23
7.1	Return authorisation	23
7.2	Shipping and packing considerations	23
9	Appendix	24

1 Safety and regulations

1.1 Important safety instructions



The lightning flash with an arrowhead symbol within an equilateral triangle is intended to alert the user to the presence of uninsulated "dangerous voltage" within the product's enclosure that may be of sufficient magnitude to constitute a risk of electric shock to persons.



The exclamation point within an equilateral triangle is intended to alert the user of the presence of important operating and maintenance (servicing) instructions in the literature accompanying the appliance.

Safety instructions - read this first

1. Read these instructions.
2. Keep these instructions.
3. Heed all warnings.
4. Follow all instructions.
5. Do not use this apparatus near water.
6. Clean only with a dry cloth.
7. Do not block any ventilation openings. Install in accordance with the manufacturer's instructions.
8. Do not install near any heat source such as radiators, heat registers, stoves, or other such apparatus that produce heat.
9. Do not defeat the safety purpose of the grounding-type plug. A grounding type plug has two blades and a third grounding prong. The third prong is provided for your safety. If the provided plug does not fit into your outlet, consult an electrician for replacement of the obsolete outlet.
10. Protect power cords from being walked on or pinched particularly at plugs, convenience receptacles, and the point where they exit the apparatus.
11. Only use attachments and accessories specified by Void Acoustics.
12. Only use with the cart, stand, tripod, bracket, or table specified by the manufacturer, or sold with the apparatus. When a cart is used, use caution when moving the cart/apparatus combination to avoid injury from tip-over.
13. Unplug the apparatus during lightning storms or when unused for long periods of time.
14. Refer all servicing to qualified service personnel. Servicing is required when the apparatus has been damaged in any way, such as when the power-supply cord or plug is damaged, liquid has been spilled or objects have fallen into the apparatus, the apparatus has been exposed to rain or moisture, does not operate normally, or has been dropped.
15. Since the mains power supply cord attachment plug is used to disconnect the device, the plug should always be easily accessible.
16. Void loudspeakers can produce sound levels capable of causing permanent hearing damage from prolonged exposure. The higher the sound level, the less exposure needed to cause such damage. Avoid prolonged exposure to the high sound levels from the loudspeaker.

1.2 Limitations

This guide is provided to help familiarise the user with the loudspeaker system and its accessories. It is not intended to provide comprehensive electrical, fire, mechanical and noise training and is not a substitute for industry-approved training. Nor does this guide absolve the user of their obligation to comply with all relevant safety legislation and codes of practice.

While every care has been taken in creating this guide, safety is user-dependent and Void Acoustics Research Ltd cannot guarantee complete safety whenever the system is rigged and operated.

1.3 EC declaration of conformity

Manufacturer:

Void Acoustics Research Ltd,
Unit 15 Dawkins Road Ind Est,
Poole, Dorset,
BH15 4JY,
United Kingdom.



We declare the under our sole responsibility the following product models: Venu 6 V2, 8 V2, 10 V2, 12 V2, 15 V2, 112 V2, 212 V2, 115 V2, 215 V2, 210i V2

are intended to be used as loudspeakers and are in conformity with the following EC Directives, including all amendments, and with national legislation implementing these directives and standards:

- 2006/95/EC Low Voltage Directive
- 2004/108/EC Electromagnetic Compatibility Directive
- 2002/95/CE RoHs Directive
- BS EN 60065:2002
- BS EN 55103-1/-2
- BS EN 61000-3-2
- BS EN 61000-3-3
- BS EN 61000-4-2
- BS EN 61000-4-3
- BS EN 61000-4-4
- BS EN 61000-4-5
- BS EN 61000-4-6
- BS EN 61000-4-11

Alex Skan
Technical Director

1.4 WEEE directive

If the time arises to throw away your product, please recycle all the components possible.



This symbol indicates that when the end-user wishes to discard this product, it must be sent to separate collection facilities for recovery and recycling. By separating this product from other household-type waste, the volume of waste sent to incinerators or land-fills will be reduced and natural resources will thus be conserved.

The Waste Electrical and Electronic Equipment Directive (WEEE Directive) aims to minimise the impact of electrical and electronic goods on the environment. Void Acoustics Research Ltd complies with the Directive 2002/96/EC and 2003/108/EC of the European Parliament on waste electrical and electronic equipment (WEEE) in order to reduce the amount of WEEE that is being disposed of in land-fill sites. All of our products are marked with the WEEE symbol; this indicates that this product must NOT be disposed of with other waste. Instead it is the user's responsibility to dispose of their waste electrical and electronic equipment by handing it over to an approved reprocessor, or by returning it to Void Acoustics Research Ltd for reprocessing. For more information about where you can send your waste equipment for recycling, please contact Void Acoustics Research Ltd or one of your local distributors.

2 Limited warranty

The warranty

For a period of three (3) years from the date of delivery to the original purchaser (as shown on the original invoice or sales receipt; a copy of this may be required as proof of warranty dates), Void Acoustics Research Ltd (hereinafter 'Void') warrants to the Original Owner (person or company who originally purchased the product brand new from either Void or a Void Authorised Dealer/Distributor) of each new Venu Series product (provided it was purchased at an Authorised Void Dealer) that it is free of defects in materials and workmanship and that each product will meet or exceed all factory published specifications for each respective model. Void agrees to repair or replace (at its discretion) all defective parts at no charge for labour or materials; subject to following provisions:

Warranty violations

Void shall take no responsibility for repair or replacement as specified under this warranty, if the damaged product has been subject to misuse, accident, neglect or failure to comply with normal maintenance procedures; or if the serial number has been defaced, altered or removed. Nor will Void accept responsibility for, or resulting from, improper alterations or unauthorised parts or repairs. This warranty does not cover any damage to speakers or any other consequential damage resulting from breach of any written or implied warranty.

Void warranty provisions

Void will remedy any defect, regardless of the reason for failure (except as excluded) by repair, or replacement. Void will remedy the defect and ship the product within a reasonable time after receipt of the defective product at a Void Authorised Service Centre.

To obtain warranty service

If a Void product requires service, the Owner must contact Void or an Authorised Void Service Centre to receive an R.A.N. (Return Authorisation Number) and instructions on how to return the product to the Void Authorised Service Centre, or to Void.

Void (or its Authorised Service Centre) will initiate corrective repairs upon receipt of the returned product. Please save the original carton and all the packing materials in case shipping is required. All products being returned to the factory or service centre for repairs must be shipped prepaid.

If the repairs made by Void or the Void Authorised Service Centre are not satisfactory, the Owner is instructed to give written notice to Void. If the defect or malfunction remains after a reasonable number of attempts by Void to remedy the defect or malfunction, the Original Owner shall then have the option to elect either a refund or replacement of said Void product free of charge. The refund shall be an amount equal to but not greater than the actual purchase price, not including any taxes, interest, insurance, closing costs and other finance charges (minus reasonable depreciation on the product). If a refund is necessary, the Original Owner must make the defective or malfunctioning product available to Void free and clear of all liens or other restrictions.

Equipment modifications

Technical and design specifications are subject to change without notice.

Void reserves the right to modify or change equipment (in whole or part) at any time prior to delivery thereof, in order to include therein electrical or mechanical improvements deemed appropriate by Void, but without incurring any liability to modify or change any equipment previously delivered, or to supply new equipment in accordance with any earlier specifications.

Disclaimer of consequential and incidental damages

You, the Original Owner, are not entitled to recover from Void any incidental damages resulting from any defect in the Void product.

This includes any damage to another product or products resulting from such a defect.

Warranty alterations

No person has the authority to enlarge, amend, or modify this Warranty. This Warranty is not extended by the length of time which the Original Owner is deprived of the use of product. Repairs and replacement parts provided pursuant to the Warranty shall carry only the non-expired portion of the Warranty.

This Statement of Warranty supersedes all others contained in this user guide.

3 Unpacking and checking

All Void Acoustics products are carefully manufactured and thoroughly tested before being dispatched. Your dealer will ensure that your Void products are in pristine condition before being forwarded to you but mistakes and accidents can happen.

Before signing for your delivery:

- Inspect your shipment for any signs of contamination, abuse or transit damage as soon as you receive it
- Check your Void Acoustics delivery fully against your order
- If your shipment is incomplete or any of its contents are found to be damaged; inform the shipping company and inform your dealer.

When you are removing your Venu 210i V2 loudspeaker from its original packaging:

- Venu 210i V2 loudspeakers come double boxed and each box is stapled shut; take care when unboxing and removing the staples to avoid injury or damage to the loudspeaker
- If you need to place the Venu loudspeaker on a flat surface ensure you use a lint free product to protect the finish
- When you have removed the Venu 210i V2 loudspeaker from the packaging inspect it to ensure there is no damage and keep all original packaging in case it needs to be returned for any reason.

See section 2 for warranty conditions and see section 7 if your product needs servicing.

4 About

4.1 Welcome

Many thanks for purchasing this Void Acoustics Venu 210i V2 loudspeaker. We truly appreciate your support. At Void, we design, manufacture and distribute advanced professional audio systems for the installed and live sound market sectors. Like all Void products, our highly skilled and experienced engineers have successfully combined pioneering technologies with groundbreaking design aesthetics, to bring you superior sound quality and visual innovation. In buying this product, you are now part of the Void family and we hope using it brings you years of satisfaction. This guide will help you both use this product safely and ensure it performs to its full capability.

4.2 Venu 210i V2 overview

The Venu 210i V2 is a 1200 Watt, self-powered, double 10" reflex-loaded low frequency enclosure capable of powering up to four mid-high enclosures from its built-in dual 600 Watt power modules. Providing a frequency response of 40 Hz – 150 kHz \pm 3 dB and a continuous output of 124 dB, peaking at 130 dB, it is ideal for filling large venues with noteworthy levels of bass.

speakONTM sockets are provided for quick and reliable connections and a protected rear connector panel allows the enclosure to be placed against a rear wall without damaging the audio or power connections.

The 210i also features DSP for loudspeaker control and advanced signal processing capabilities that can be accessed via the rear USB port. Add to this the evocative Void sound from the new range of custom designed components and it's clear that Venu is the ultimate installation series.

4.3 Key features

- 2400 W RMS (1200 W + 2 x 600 W)
- Capable of powering up to four mid high enclosures
- 2 x 10" low frequency drivers
- Built-in DSP
- Textured polyurea finish, optional custom colours
- Perforated steel grille

4 About

4.4 Venu 210i V2 specifications

Bass frequency range	40 Hz - 150 Hz \pm 3 dB
Input	2 x 10 k Ω balanced
Maximum output	124 dB cont, 130 dB peak
Driver configuration	2 x 10" LF
Height	334 mm (13.1")
Width	676 mm (26.6")
Depth	530 mm (21.1")
Weight	32 kg (70.5 lbs)
Enclosure	15 mm birch plywood
Finish	Textured polyurea
Grille	Powder-coated perforated steel - foam filter
Output	2 x Neutrik speakON™
2-channel output mode	
4 Ω / Ch (balanced)	600 W
8 Ω / Ch (balanced)	400 W
Max output voltage	85 V _{peak}
Max output current	31 A _{peak}
Nominal power requirement	AC 100 V - 240 V, 50/60 Hz with PFC
Power factor	cos φ = 0.9 @ 360 W
Consumption	
Standby	0.5 W
Idle	13.5 W
1/8 of max output power @ 8 Ω	220 W
Amplifier and DSP features	
DSP	Analogue Devices SigmaDSP™
S/N Ratio	115 dB
Crosstalk separation	85 dB @ 1kHz
Input sensitivity	3 V _{RMS} / 11.7 dBu
Input impedance	10 k Ω balanced
THD+N / DIM100	< 0.08% from 0.1 W to full power (typically <0.05%)
Slew rate	50 V/ μ s @ 8 Ω , input filter bypassed
Damping factor @ 8 Ω	<10000 @ 100 Hz
Delay	340 ms input delay, 10 ms per channel output delay
Input equalizer	5 parametric equalizers: hi/lo-shelving, all-pass, band-pass, band-stop, hi/lo-stop
Output equalizer	Parametric IIR filters: peaking, hi/lo-shelving, all-pass, band-pass, band-stop, hi/lo-pass
Crossover	Butterworth, Linkwitz-Riley, Bessel: 6 dB/oct to 48 dB/oct (IIR)
Limiters	Peak limiter, RMS limiter, frequency dependent RMS limiter, Clip limiter, Temperature limiter

4 About

4.5 Dimensions

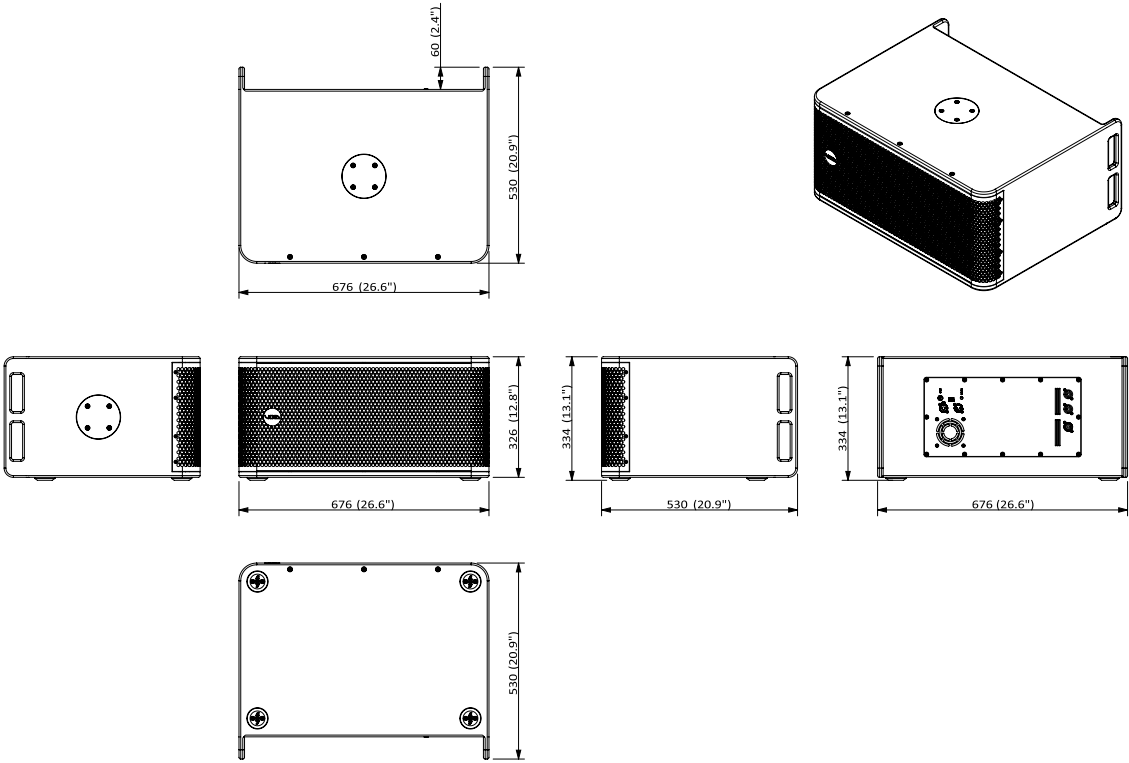

Figure 4.1: Dimensions

5 Cabling and wiring

5.1 Electrical safety

To avoid electrical hazards please note the following:



- Do not access the inside of any electrical equipment. Refer servicing to Void-approved service agents.

5.2 Cable considerations for fixed installations

We recommend specifying installation-grade Low Smoke Zero Halogen (LSZH) cables for permanent installations. The cables should use Oxygen Free Copper (OFC) of grade C11000 or above. Cables for permanent installations should be compliant with the following standards:

- IEC 60332.1 Fire retardancy of a single cable
- IEC 60332.3C Fire retardancy of bunched cables
- IEC 60754.1 Amount of Halogen Gas Emissions
- IEC 60754.2 Degree of acidity of released gases
- IEC 61034.2 Measurement of smoke density.

5 Cabling and wiring

5.3 Venu 210i V2 wiring

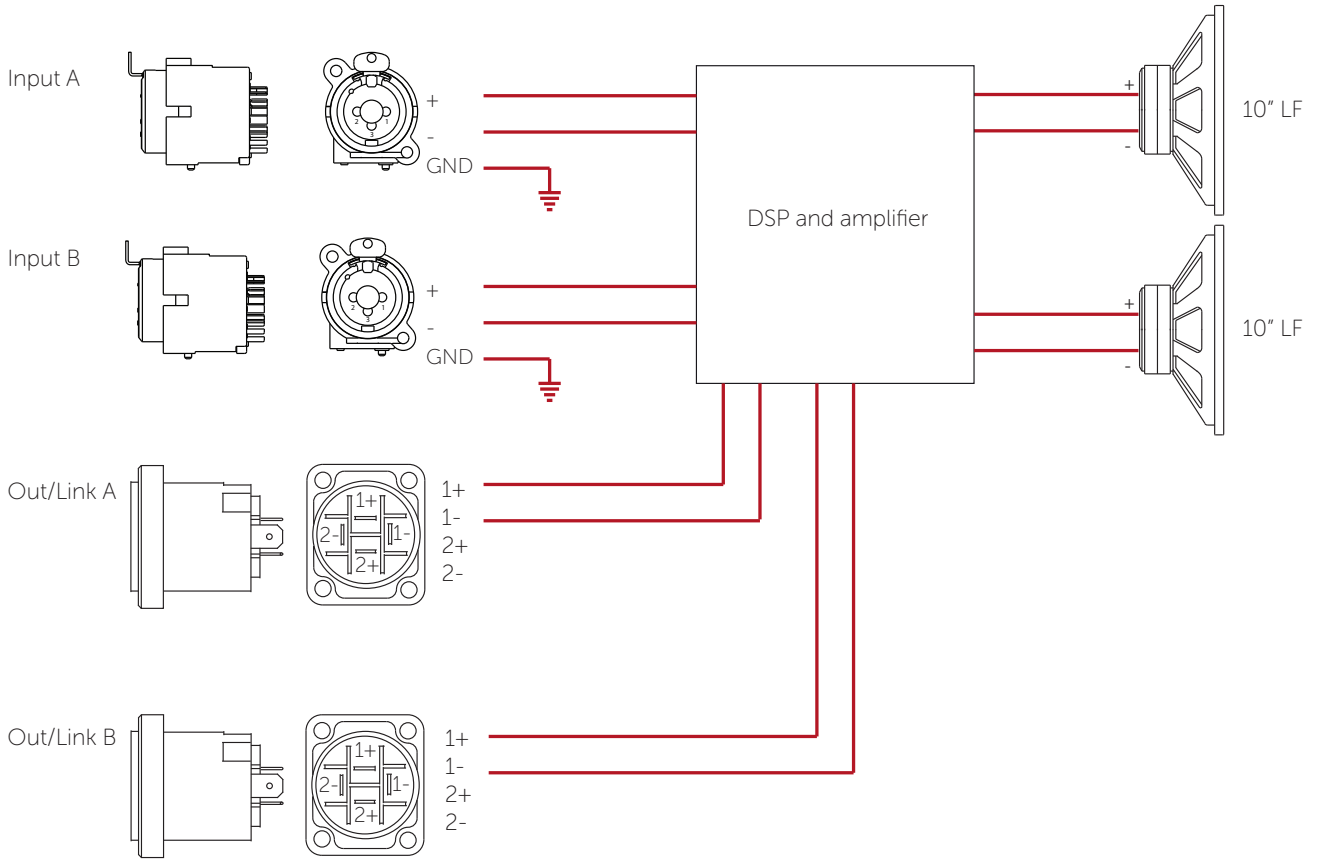

Figure 5.1: Venu 210i V2 wiring diagram

Input	
	XLR pins +/-
Input A	2 x 10" LF
Input B	2 x 10" LF

Output		
	speakON™ pins 1+/1-	speakON™ pins 2+/2-
Link/out A	Link	n/c
Link/out B	Link	n/c

5 Cabling and wiring

5.4 Input connectors

Analogue input XLR-M pinout

Pin 1	GND
Pin 2	Hot +
Pin 3	Cold -

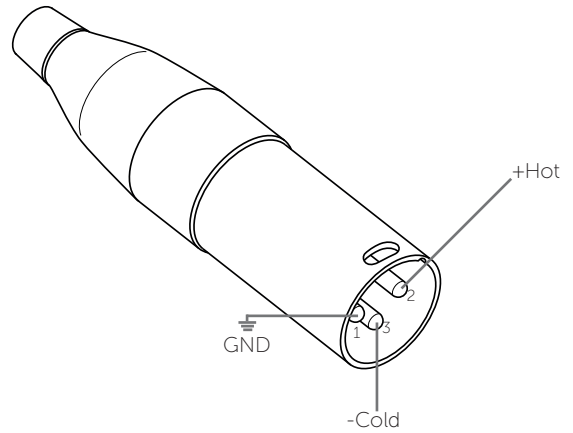

Figure 5.2: XLR-M diagram

Analogue input TRS Jack pinout

Tip	Hot +
Ring	Cold -
Sleeve	GND

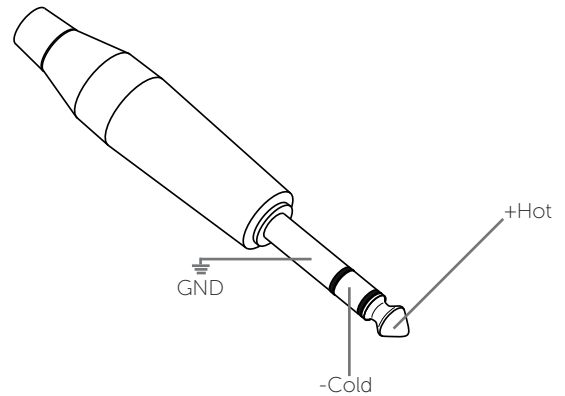

Figure 5.3: TRS Jack diagram

5.5 Output connectors

Analogue line output Neutrik speakON™

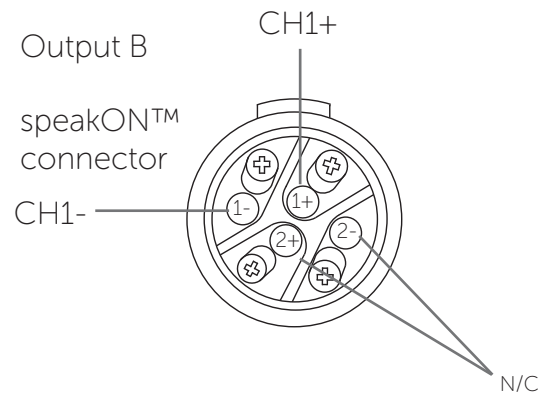
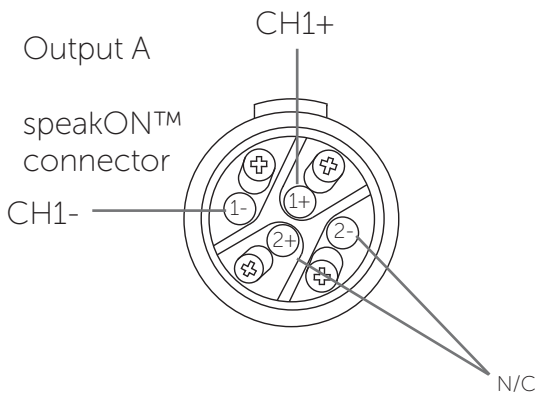

Figure 5.4: Channel 1 and 2 speakON™ connector diagram. Note: pins 2+/2- are not connected.

6 Venu 210i V2 DSP

6.1 Components

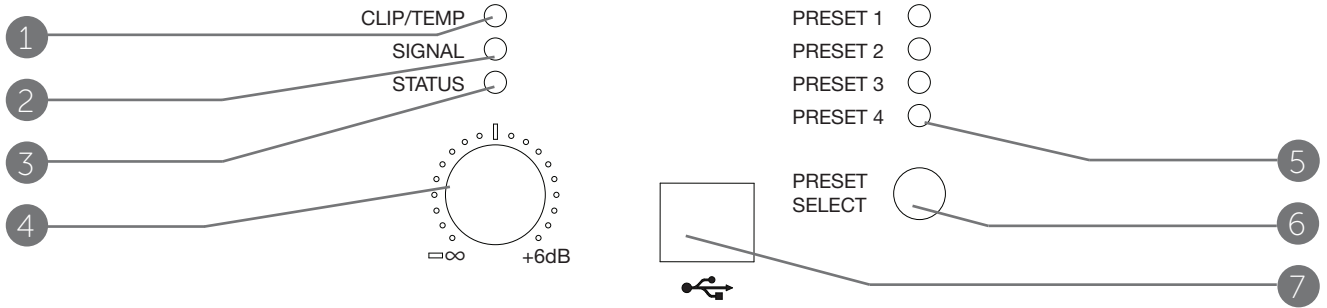

Figure 6.1: LED panel

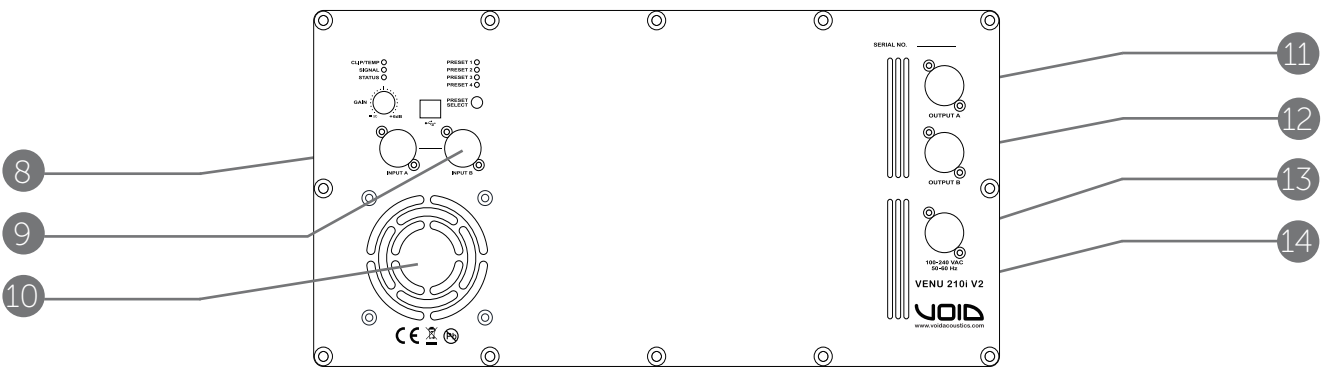

Figure 6.2: Rear panel

- | | |
|---|---|
| <ul style="list-style-type: none"> 1. Signal clipping 2. Signal presence/limiting LED 3. Status LED 4. Volume potentiometer 5. Preset LEDs 6. Preset select 7. USB-B programming connector 8. Combi Jack - XLR input signal connector input A | <ul style="list-style-type: none"> 9. Combi Jack - XLR input signal connector input B 10. Fan Inlet 11. Neutrik speakON™ output A 12. Neutrik speakON™ output B 13. PowerCon™ power input 14. Exhaust vents |
|---|---|

6 Venu 210i V2 DSP

6.2 Factory presets

Factory presets for the Venu 210i V2 are as follows:

Preset 1	Air 8
Preset 2	Cyclone 55
Preset 3	Indigo 6S
Preset 4	Venu 6 V2

6.3 Selecting your preset

To change your Venu 210i V2 preset:

1. Apply power to the amplifier
2. Wait 15 seconds for the amplifier to initialize
3. Press the preset button
4. The next selected preset light will begin flashing
5. When the preset LED stops flashing and becomes steady the amplifier is ready to use in that preset mode.

For alternative compatible loudspeaker presets please contact your Void representative.

6.4 LED chart

Clip/temp LED

Colour	Solid on	Action required
Off	Temperature OK, no clipping	No action required
Yellow	High amplifier temperature	Reduce system gain
Red	Output signal clipping	Reduce system gain

Signal LED

Colour	Solid on	Action required
Green	Input signal present, output not in limit	No action required
Yellow	Output limiter engaging	Reduce system gain
Red	Input signal clipping	Reduce input gain

Status LED

Colour	Solid ON
Off	System off
Green	System ready to play

6 Venu 210i V2 DSP

6.5 Software

Starting from version 2.11.1, Armonía Pro Audio Suite supports the Venu 210i V2 processing board which is available from:

http://www.voidacoustics.com/void_uploads/Armonia.zip

In order to access the DSP via the USB port of your computer, the CP210x USB to UART Bridge Virtual COM Port (VCP) drivers are required.

Freely download the drivers from the Silicon Labs website: www.silabs.com > Products > USB bridge > Software download > CP210x VCP Drivers:

<https://www.silabs.com/products/mcu/Pages/USBtoUARTBridgeVCPDrivers.aspx>

1. Once the driver has been properly installed, the Windows operating system provides a new virtual COM port with a high identification number.
2. Open Armonía Pro Audio Suite and click on the Armonía button in the top left corner of the window.
3. Click on the Option button and select the Communication Manager tab.

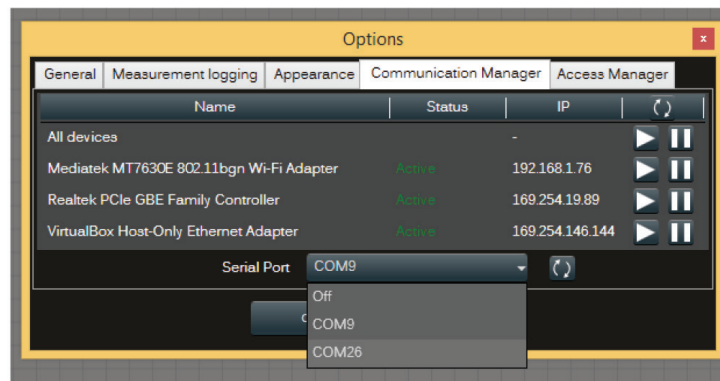

Figure 6.3: Armonía Pro Audio suite communications manager

4. Activate the Serial Port communication and select the proper COM port (usually the one with the higher ID).
5. Apply the changes: now Armonía is capable to discover the attached device.

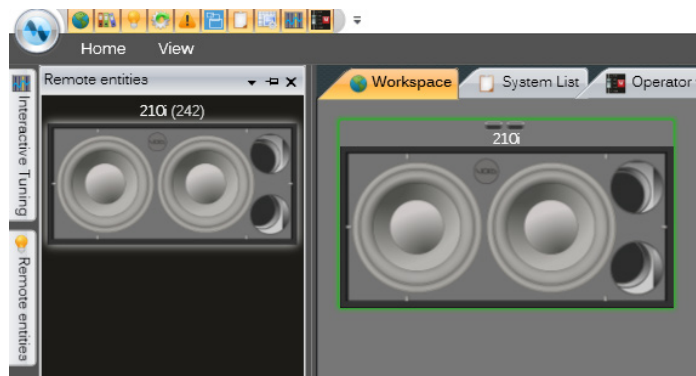
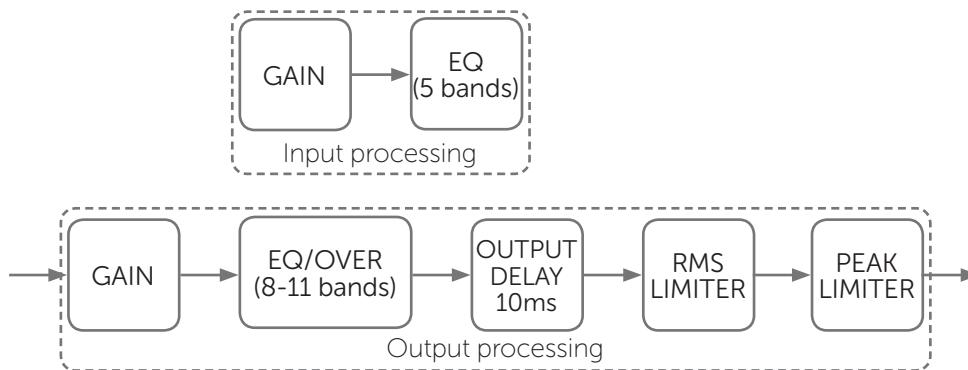
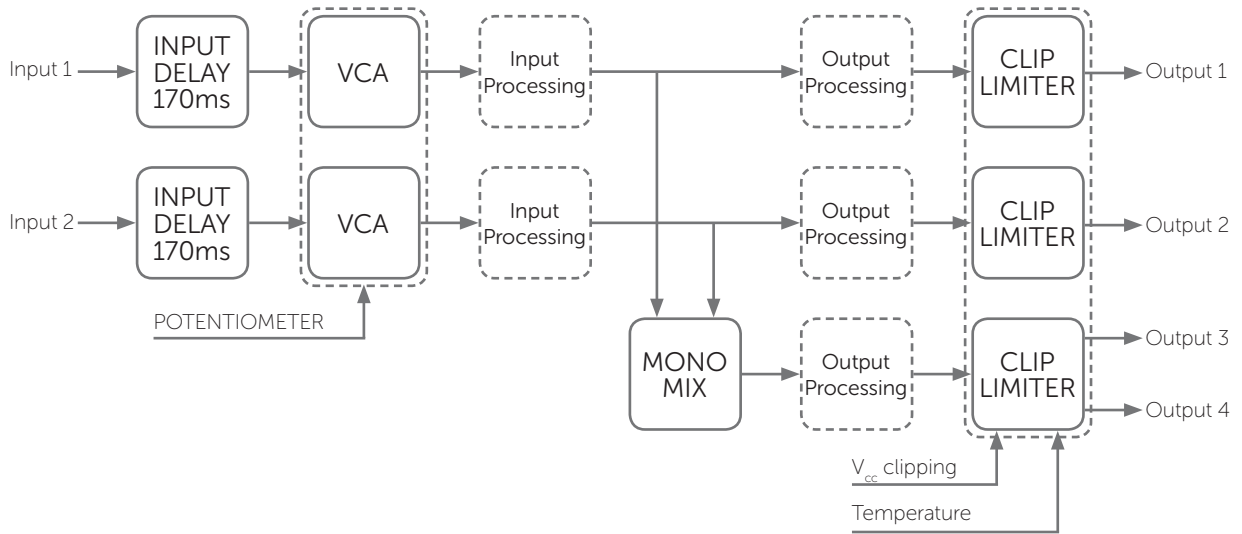

Figure 6.4: Unit embedding DSP-L discovered

6 Venu 210i V2 DSP

6.6 Processing architecture



6 Venu 210i V2 DSP

6.7 Internal signal path polarity

In order to increase the power's supply energy storage efficiency, signals coming from channel pairs 1-2 are polarity reversed, one with respect to the other within the pair, when entering the amplifier. This ensures a symmetrical use of the voltage rails: if, for example, both channels' 1 and 2 input signals are going through a peak at the same time, channel 1's energy will come from the positive voltage rails while channel 2, whose polarity is reversed with respect to channel 1, will be fed energy from the negative voltage rails. In this manner, the power supply will work symmetrically, with one channel catered by the positive rails and the other by the symmetrical negative rails. Channel 2's signal will be polarity reversed once more to ensure that both channels output with the same polarity as their corresponding input signals.

For this reason it is very important not to invert the polarity of either channels before feeding them to the module. A double polarity inversion (the first by the user inserting the input signal and the other by the amplifier's internal circuitry) results in no inversion at all. If this were the case, both channels would be weighing on only one side (positive or negative) of the power supply's voltage rails. This would result in an inefficient use of the power supply's energy. Please pay special attention in using balanced inputs on all measurement equipment (such as oscilloscope probes) when you are bench testing.

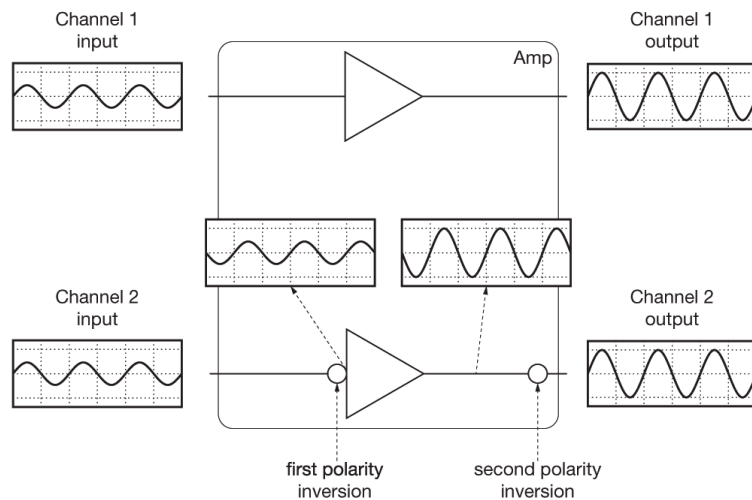

Figure 6.5: Internal signal path polarity with example input signal. Both channels 1 and 2 are fed with the sma sine signal.

7 System design

7.1 System design principles

High frequency loudspeakers can be arrayed as a single pair facing forward to provide a wide stereo image.

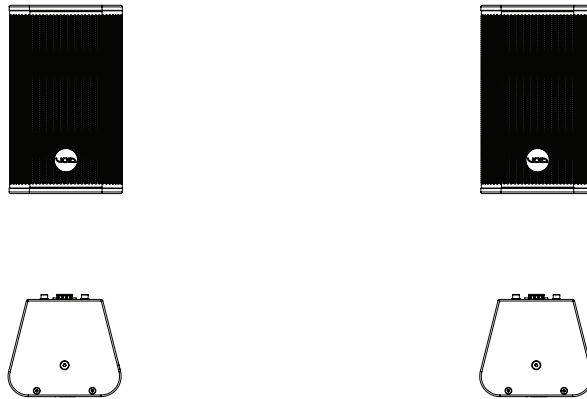

Figure 7.1: Loudspeakers single pair arrangement

For applications requiring wide horizontal coverage, use two loudspeakers in pairs. To ensure an even coverage take the horizontal dispersion of the high frequency enclosure and divide it by two and subtract 5° to determine the angle of separation. The example in figure 7.2 is of the Venu V2 Series where the horizontal dispersion is 90°, so $(90^\circ \div 2) - 5^\circ = 40^\circ$.

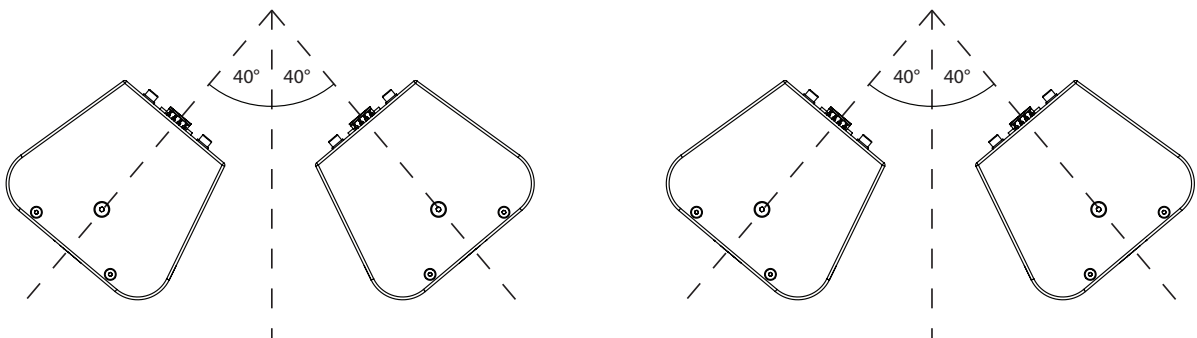

Figure 7.2: Loudspeaker dual pair arrangement

For permanent installation, it is recommended to fly high frequency loudspeakers for more even coverage. This also allows co-located low frequency enclosures in a single block, increasing sensitivity and providing more consistent bass coverage.

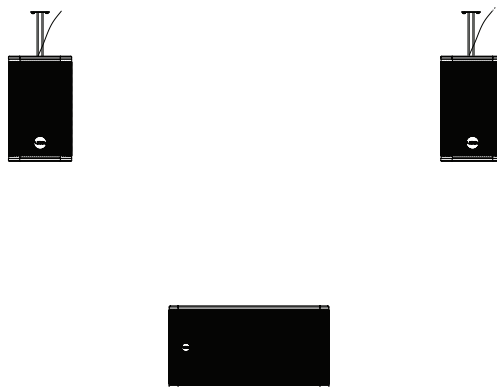

Figure 7.3: Venu ceiling mounting

7 System design

7.2 High frequency loudspeaker placement and positioning

When deploying high frequency loudspeakers, it is important to consider the speakers' vertical position to maximise coverage in the vertical axis. Horizontal loudspeaker dispersion figures dictate the coverage of the loudspeaker, left to right, to the -3 dB points. The same can be said for the vertical dispersion figure, but when applied to a listening area, this figure dictates the audience area coverage front to back.

Vertical dispersion is often overlooked or not assessed properly, resulting in inefficiently deployed loudspeaker systems that require more fill loudspeakers than are necessary to achieve required coverage. Following are some basic guidelines when considering the vertical position of your high frequency loudspeaker.

With optimum vertical positioning and aiming applied the loudspeaker system can be used at maximum efficiency. With a point source loudspeaker in this configuration the speaker is placed 2m-4m from the ground, aimed half way to two thirds of the way back from the audience area, as shown in figure 7.5. The applied aiming reduces unwanted reflections from the ceiling and directs the highest energy concentration to the audience area requiring it most. This is the most desirable position for the loudspeakers in this example.

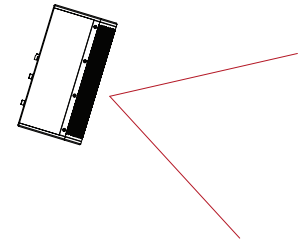

Figure 7.4a: Vertical dispersion (side view)

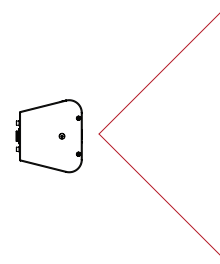

Figure 7.4b: Horizontal dispersion (top view)

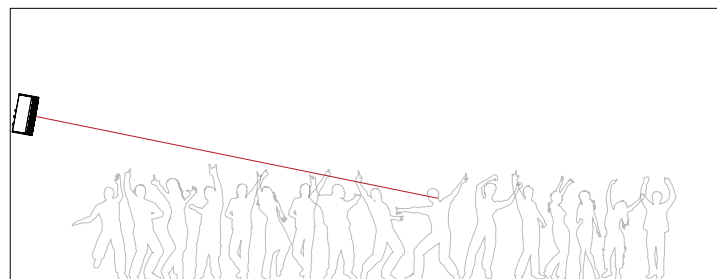

Figure 7.5: Correct loudspeaker placement



7 System design

A multi-point loudspeaker system in a club/bar environment can be very pleasing for the listener. However, it's important that the processes applied to previous examples are still implemented. In figure 7.6 you can see the loudspeakers have been positioned and aimed optimally. When deploying a multi-point loudspeaker system, extra consideration must be taken to counter unwanted room effects. Careful positioning and aiming of loudspeakers will minimise room effects, while maintaining even coverage throughout the audience area.

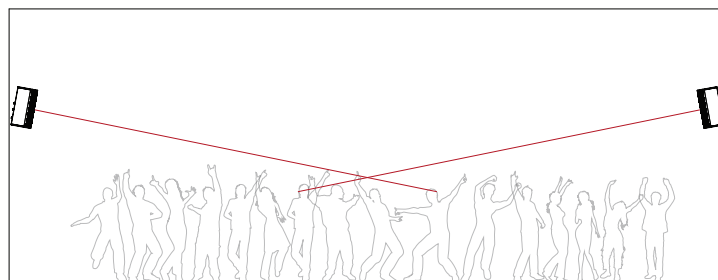

Figure 7.6: Multi point loudspeaker arrangement

In the horizontal plane rotate the high frequency loudspeakers toward the audience area at an angle such that the centre line of the dispersion from each loudspeaker meets about two thirds of the way towards the rear of the audience area. This will help provide a wider coverage and result in more of the power being used usefully.

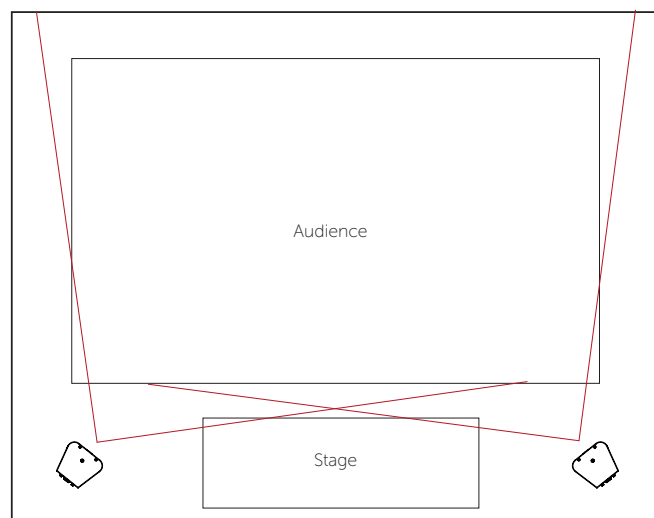

Figure 7.7: Correct horizontal dispersion

7 System design

Avoid directing the high frequency loudspeaker straight forward. This will result in a proportion of the power being directed towards the walls, creating possible reflective issues, as well as causing a gap in coverage at the centre of the audience area.

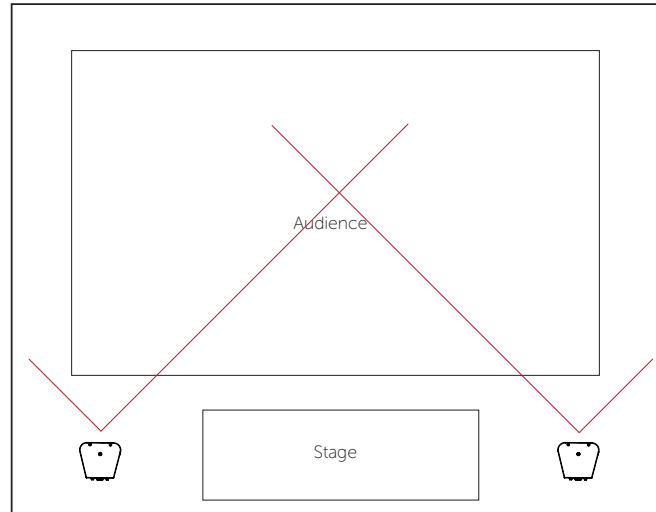

Figure 7.8: Incorrect horizontal dispersion



In figure 7.9 the loudspeakers vertical positioning is too low for the audience area. Mid and high range frequencies are absorbed by the first two rows of people, resulting in poor coverage and potential acoustic issues from room reflections.

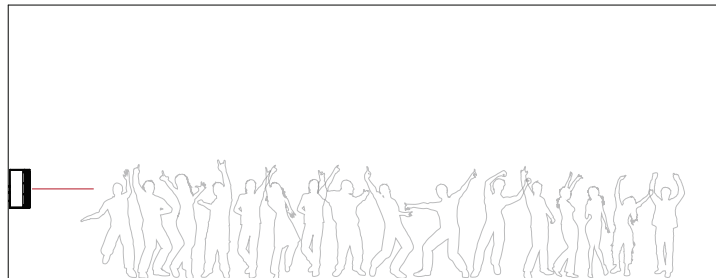

Figure 7.9: Incorrect loudspeaker placement



Figure 7.10 shows the loudspeaker vertical position is optimal for the audience area but the user hasn't applied an aiming angle. In this case, a large portion of energy is directed at the ceiling that could result in reduced intelligibility and unwanted room acoustic characteristics. The shallow angle of attack will also induce refraction issues on a hot dance floor, leading to reduced HF penetration at mid and far distances, again reducing intelligibility and coherence.

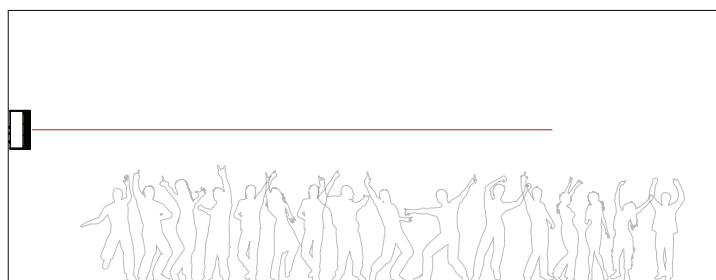

Figure 7.10: Incorrect loudspeaker placement



7 System design

7.3 Bass alignment - delay times



Note: All information given here is a guide and not a rule. Taking measurement on site and using your ear are still the most reliable way to achieve the best results.

When designing loudspeakers and low frequency enclosures layout within a space it is often necessary to apply delay to optimise system performance. In figure 7.11 we have a room with four Venu loudspeakers and single low frequency enclosure.

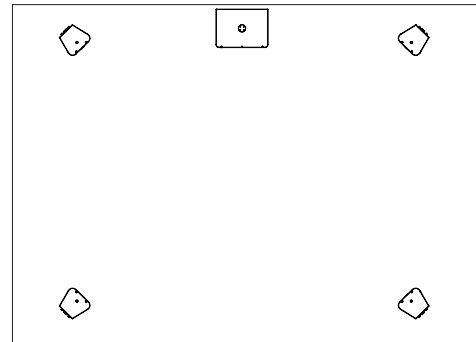

Figure 7.11: Bass alignment

All four loudspeakers sit on a circle of radius R with its centre point at O . The low frequency enclosure is situated at a distance A from the origin and a distance B from the circumference of the circle. The distance B will determine the delay required for the low frequency enclosure of 2.9 ms per metre. So, in this example, if the distance B is 2 m the a delay of 5.8 ms would be required.

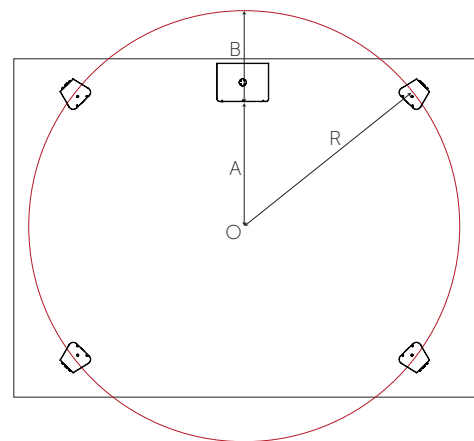

Figure 7.12: Bass alignment example 1

Figure 7.13 shows a second low frequency enclosure added. Here we are looking to create a secondary focal point at E . To calculate our delay time we take distance D , which is point E to the south edge of the circle, away from A , which is E to the north edge of the circle, and multiply by the delay time per metre. Or:

$$(A - D) \times 2.9 \text{ ms/m} = \text{delay time.}$$

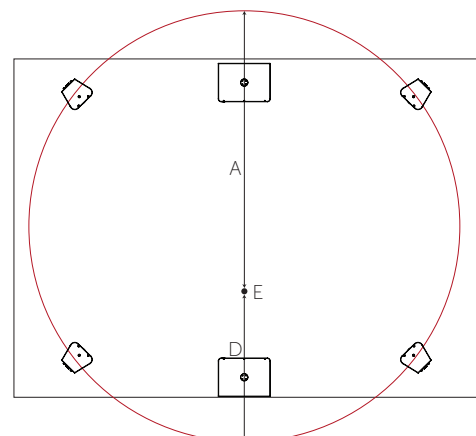

Figure 7.13: Bass alignment example 2

8 Service

Void Venu 210i V2 loudspeakers should only be serviced by a fully-trained technician.



No user serviceable parts inside. Refer servicing to your dealer.

8.1 Return authorisation

Before returning your faulty product for repair, please remember to get an R.A.N. (Return Authorisation Number) from the Void dealer who supplied the system to you. Your dealer will handle the necessary paperwork and repair. Failure to go through this return authorisation procedure could delay the repair of your product.

Note that your dealer will need to see a copy of your sales receipt as proof of purchase so please have this to hand when applying for return authorisation.

8.2 Shipping and packing considerations

- When sending a Void Venu 210i V2 loudspeaker to an authorised service centre, please write a detailed description of the fault and list any other equipment used in conjunction with the faulty product.
- Accessories will not be required. Do not send the instruction manual, cables or any other hardware unless your dealer asks you to.
- Pack your unit in the original factory packaging if possible. Include a note of the fault description with the product. Do not send it separately.
- Ensure safe transportation of your unit to the authorised service centre.

9 Appendix

Architectural Specifications

The loudspeaker shall be active comprised of two high power 10" (254 mm) direct radiating, reflex loaded low frequency (LF) transducers.

The enclosure shall be rectangular constructed from 15 mm multi-laminated birch plywood with a wraparound grille and a rotating badge; it shall have a removable cover plate for fixing an optional M20 top hat and it shall be finished in a textured polyurethane with external dimensions of (H) 334 mm x (W) 684 mm x (D) 530 mm (13.2" x 26.9" x 20.9") and weigh 31 kg (68.3 lbs).

Performance specifications of a typical production unit shall be as follows: frequency response of 40 Hz – 150 Hz (± 3 dB from rated sensitivity); 1200 W long-term program per voice coil using EIA RS-426A pink noise (6 dB crest factor); pressure sensitivity of 99 dB at one Watt 100 Hz – 10 kHz at one metre; rated nominal impedance of 4 Ω .

The system shall be powered by its own internal 1200 W dedicated power amplification module with DSP management with two 600 W at 4 Ω full range outputs.

The low frequency transducer shall be constructed on a cast aluminium frame with a treated paper cone, 101.6 mm (4") voice, wound with copper wire on a high-quality voice coil former for high power handling and long-term reliability.

The loudspeaker system shall be a Void Acoustics Venu 210i V2.

North America

Void Acoustics North America
503-854-7134
sales.usa@voidacoustics.com

Head Office

Void Acoustics Research Ltd
Unit 15 Dawkins Road Industrial Estate
Poole
Dorset
BH15 4JY
England

+44 (0) 1202 666 006
info@voidacoustics.com

Registered in England & Wales No. 07533536

www.voidacoustics.com

